

Argos Cardiac Output Monitor



Operator's Manual

60-001 Rev I.
04-MAY-2026



The Retia Medical Argos Cardiac Output Monitor Operator's Manual



WARNING

Do not use the Argos monitor if the monitor shows evidence of having been opened or tampered with. If the monitor shows signs of tampering, the monitor should be immediately returned to Retia for inspection. Please call Retia Medical customer support to report the issue and receive assistance.

Prices and specifications are subject to change without notice. If this manual is changed, it will be re-issued. If, during the use of this manual, errors, omissions or incorrect information are discovered please contact Retia Medical.



Issued by:
Retia Medical Systems, Inc.
333 Westchester Ave.
White Plains, NY, 10604
USA



For EU Customers Only:
RQMIS AREU S.L.U
Via Augusta 123
08006 Barcelona
Spain



Casus Switzerland GmbH
Hinterbergstrasse 49
6312 Steinhausen
Switzerland



UK Responsible Person
RQMIS AR Ltd.
4 Whitan Way Whitney,
Oxfordshire OX28 6FF,
United Kingdom



Trademark: Retia Medical™, the Retia Logo, Retia™, Argos™ and MBA™ (multi beat analysis) are trademarks of Retia Medical Systems, Inc. All other trademarks are the property of their respective owners.

Copyright © 2025 Retia Medical Systems, Inc. All rights reserved.

Manufacturer's Declaration of Conformity Electronic Emissions and Immunity

Guidance and Manufacturer's Declaration – Electromagnetic Emissions		
The Argos monitor is intended for use in the electromagnetic environment specified below. The customer or the user of the Argos should ensure that it is used in such an environment.		
Emissions Test	Compliance	Electromagnetic environment
RF emissions. CISPR 11	Conducted Emissions Class B	The Argos uses RF energy only for internal function therefore RF emissions are low and are not likely to cause any interference with nearby electrical equipment.
RF emissions. CISPR 11	Radiated Emissions Class B	The Argos is suitable for use in all establishments, including domestic establishments and those directly connected to the public low-voltage power supply network that supplies buildings used for domestic purposes.
Harmonic Emissions IEC 6100-3-2	Class D	
Voltage Fluctuations/ Flicker Emissions IEC 61000-3-3	Complies	

Guidance and Manufacturer's Declaration – Electromagnetic Immunity			
The Argos is intended for use in the electromagnetic environment specified below. The customer or the user of the Argos should ensure that it is used in such an environment.			
Immunity Test	IEC 60601 Test Level	Compliance Level	Electromagnetic Environment Guidance
Electrostatic discharge (ESD). IEC 61000-4-2 Ed. 2.0 2008-12	±15kV Air ±8kV Contact	Complies	Floors should be wood, concrete, or ceramic tile. If floors are covered with synthetic material, the relative humidity should be at least 30%.
RF interference. IEC 61000-4-3 Radiated Immunity	80-1000 MHz,	20V/M	RF generating equipment should be used no closer to the Argos or connected cables than the recommended separation distance, according to the following formulas:
RF Interference. IEC 61000-4-3 Radiated Immunity	1.0 to 2.7GH	20V/M	$d = \sqrt{p} * 1.17 \text{ for } 150\text{kHz to } 80\text{MHz}$ $d = \sqrt{p} * 1.75 \text{ for } 80\text{MHz to } 800\text{MHz}$ $d = \sqrt{p} * 0.35 \text{ for } 800\text{MHz to } 2.5\text{GHz}$ <p>Devices marked with this symbol are known to be sources of RF energy.</p> 

Guidance and Manufacturer's Declaration – Electromagnetic Immunity (cont'd)			
Immunity Test	IEC 60601 Test Level	Compliance Level	Electromagnetic Environment Guidance
Voltage Dips, short interruptions and voltage variations on power supply lines. IEC-61000-4-4 Ed 3.0 2012-04 Electrical Fast Transient Burst, Power Ports	.5kV, 1kV, 2kV, +/-, 100Khz, 5ns risetime, 50ns pulse duration, 300ms burst period, 0.75ms burst duration	Complies	Mains power quality should be that of a typical commercial or hospital environment. If user of the monitor requires continued operation during power mains interruptions, the monitor uses a built in UPS for environments where power is intermittent. Where <i>d</i> is distance measured in meters, and <i>p</i> is the power in watts of the device generating RF energy.
Power Surge IEC 6100-4-5	.5kV, 1kV Differential, .5kV, 1kV, 2kV Common Mode	Complies	
Conducted Immunity – IEC61000-4-6 ed. 4.0:2013-10.	.15 to 80MHz coupling to power port, external monitor cable, BP transducer cable	Complies	
Power Frequency Magnetic Immunity IEC61000-4-8 Ed 2, 2009-09.	30A/m RMS 50 and 60 Hz	Complies	
Voltage Dips and Interrupts IEC61000-4-11.	10, 20, 500, 5000 msec @ 230VAC, 8.3, 16.67, 500, 5000 msec @ 120VAC	Complies	

As use of electrocautery equipment can interfere with patient monitors and therefore blood pressure waveforms, and can also interfere with the RF susceptibility of the Argos monitor, it is not recommended to rely on cardiac output calculations until 5 minutes after the electrocautery tools have stopped being used.

Recommended separation distance between portable and mobile RF communication equipment and the Argos Monitor:

The Argos is intended for use in an electromagnetic environment in which radiated RF disturbances are controlled. The customer or user of the Argos can help prevent electromagnetic interference by maintaining a minimum distance between portable and mobile RF communications equipment (transmitters) and the Argos as recommended below, according to the maximum output power.

These guidelines may not apply in all situations. Electromagnetic propagation is affected by absorption and reflection from structures, objects, and people.

Rated power output of the transmitter in Watts	150kHz to 80 MHz $d = \sqrt{p} * 1.17$ in Meters	80MHz to 800MHz $d = \sqrt{p} * .175$ in Meters	800MHz to 2.5GHz $d = \sqrt{p} * 0.35$ in Meters
0.01W	0.117M	0.018M	0.035M
0.1W	0.37M	0.06M	0.11M
1W	1.17M	0.175M	0.35M
10W	3.7M	.55M	1.1M
100W	11.7M	1.75M	3.5M

Introduction

The Argos Cardiac Output Monitor is a medical device incorporating the multi-beat analysis (MBA™) algorithm that models the patient's vascular resistance to accurately measure cardiac output (CO) in high-risk patients in critical care facilities, using a radial or femoral arterial blood pressure signal.

Portability and ease of connection with bedside patient monitors, combined with a user interface that can be operated quickly and intuitively, as well as interoperability with electronic medical records (EMR) systems, make the Argos a valuable tool for clinicians to verify the hemodynamic status of the patient.

Compatible Monitors

The Argos monitor is compatible with the analog output of the following patient monitors:

1. Philips IntelliVue® Models MP40 and above (MP90, MX700, MX800) which accept the M1006B module with option #C01 Pressure Module
2. GE Carescape® Models with Patient Data Module (PDM) Solar 8000, Carescape B650, Carescape B850
3. Spacelabs Xprezzon®
4. Draeger Infinity®
5. Mindray BeneVision® N series and T series with MPM MP1 Module
6. Nihon Kohden Life Scope Gg® BSM-6000®, 3500 and 1700 Bedside Monitors

Please consult the Retia Medical website (Retia.ai) for updates to this list.

Compatible Femoral/Radial Transducers

The Argos monitor is compatible with the following blood pressure transducer components:

1. Utah Medical BP Transducer Kit (pack of 25 – 902-649)
2. Utah Medical Transducer Interface Cable FG-015

Note: These components are manufactured and distributed by Utah Medical.

How to use this manual

The Argos Cardiac Output Monitor Operator's Manual is intended for trained clinical care clinicians for use with the Argos monitor.

Do not operate the Argos monitor before reading this operator's manual and familiarizing oneself with the device's functions and capabilities for appropriate clinical use.

This Operator's Manual offers instruction and guidance on setting up and operating the Argos monitor on critically ill patients.

It covers:

- Making necessary connections to other devices
- Changing which parameters are displayed and in what form
- Navigating through informational screens
- Recalling and downloading patient monitoring information
- Care and maintenance of the Argos monitor
Contacting the manufacturer
- Approved accessories
Parameters and limits, and physical descriptions of the Argos monitor

This manual is organized into sections which, consulted sequentially, show a new user how to operate the device, and also serve as reference for the experienced operator.

Pay particular attention to highlighted and offset text, marked as cautions or warnings (⚠) or notes (▶).



CAUTION

Illustrations, including device images and screenshots, are solely intended as reference and may not precisely represent the hardware or software version of the Argos monitor the user is using.

Table of Contents

The Retia Medical Argos Cardiac Output Monitor Operator's Manual	
Manufacturer's Declaration of Conformity Electronic Emissions and Immunity	i
Introduction	iii
Compatible Monitors	iii
Compatible Femoral/Radial Transducers.....	iii
How to use this manual.....	iv
Intended Use.....	1
Indications for Use	1
Intended Use.....	1
Contraindications	1
Not Intended as a blood pressure monitor	2
Parameters	2
Pulse Pressure Variation.....	3
Warnings, Cautions, Notes, Symbols and Standards.....	4
Warnings, Cautions and Notes	4
Device Labels.....	9
Shipping Label.....	13
Standards Compliance	14
1 Initial Setup.....	15
1.1 Mounting the Argos.....	15
2 Using the Argos Monitor.....	24
2.1 Guide to screens.....	24
2.2 Trend Scrubbing	31
2.3 The Control Bar & Status Bar.....	31
2.4 The Setup Screens.....	32
2.4.1 Prepare patient.....	32
2.5 Initial setup – Input patient data	34
2.6 Search <i>Patient Record</i> Database.....	38
2.7 Steps before monitoring.....	39
2.7.1 Connected to a bedside patient monitor	40
2.7.2 Connected directly to a radial or femoral artery transducer.....	40
2.8 The Trend Screen.....	42
2.8.1 The Parameter Settings Screen.....	42
2.8.2 Display change since event.....	45
2.8.3 Display an associated index or value.....	46
2.8.4 Changing colors and graph limits.....	47
2.8.5 To change alert limits	49
2.8.6 Moving chronologically through trends.....	49

2.9	Trend Settings.....	51
2.9.1	Scaling trends.....	51
2.9.2	Trend settings: Scaling trends.....	52
2.9.3	Changing the graph range (y-axis).....	53
2.10	The Tabular View.....	55
2.10.1	Tabular view options.....	56
2.10.2	Trend scrubbing in Tabular View.....	57
2.11	The Control Bar & Status Bar.....	58
2.11.1	Battery State Indicator.....	59
2.11.2	The User Menu.....	60
2.11.3	End Session.....	61
2.11.3.1	Re-Zero Transducer.....	62
2.11.4	Export.....	62
2.11.5	Shut Down.....	63
2.11.6	About.....	64
2.11.6.1	Device Settings.....	65
2.11.6.2	Reset to default configuration.....	66
2.11.6.3	Language, Date, and Time.....	66
2.11.6.4	Monitoring Mode.....	67
2.11.6.5	Advanced Settings.....	67
2.11.6.6	Events.....	68
2.12	Dynamic Assessment Functionality.....	70
2.12.1	Assessment types.....	71
2.12.2	Canceling an Assessment.....	71
2.12.3	Fluid Bolus Assessment.....	72
2.12.4	Passive Leg Raise (PLR) Assessment.....	76
2.12.4.1	Baselines.....	79
2.12.4.2	Unstable Baseline.....	79
2.12.4.3	Invalid Baseline.....	80
2.12.4.4	Expired Baseline.....	81
2.12.5	Dynamic Assessment History.....	82
2.13	Date and Time indicator.....	83
2.14	Patient Demographics.....	83
2.15	EMR indicator (<i>licensed versions</i>).....	84
2.16	Monitoring Mode of Operations.....	85
2.17	No Signal Detected timeout.....	86
3	EMR (Electronic Medical Records) Integration.....	87
3.1.1	Entering Patient Data (<i>Licensed Version – Corepoint</i>).....	87

4	Software Management.....	92
4.1	Activating Advanced Settings.....	92
4.1.1	Installing the software license to enable EMR.....	93
4.1.2	Verifying the software license has been installed.....	93
4.1.3	License installation.....	95
4.1.4	Configuring EMR service connectivity	97
4.2	Philips Monitor Settings.....	97
4.2.1	Troubleshooting the Philips Monitor Connection.....	98
4.3	Network Settings.....	99
4.4	Configuring <i>EMR service</i>	102
4.4.1	EMR Platform.....	102
4.4.1.1	Patient Record Query	102
4.4.2	Adding EMR Server Entries.....	102
4.5	Updating the software	105
5	Help.....	110
5.1	Specifications.....	111
5.2	Equations for Calculated Patient Parameters.....	114
5.3	Default Settings.....	115
5.4	Unit Conversions.....	116
5.4.1	Lbs to/from kg.....	116
5.4.2	inches to/from cm	116
5.5	Care, Service, and Support.....	116
5.6	Cleaning the Monitor.....	116
5.7	Monitor Maintenance	116
5.8	Cable Maintenance.....	117
5.9	Data Port Maintenance	117
5.10	When Monitor Service is Required	118
5.11	Service and Support.....	118
5.12	Alert Functionality Verification	118
6	Clinical Studies	119
6.1	Chapter Overview	119
6.1.1	Results	120
7	Manufacturer's Declaration	132
7.1	Retia Medical Systems, Inc. Headquarters.....	132
7.2	Monitor Disposal.....	132
7.3	Warranty	132
	Index.....	133

List of Figures

Fig. 1-1: Rear view, showing mount holes.....	15
Fig. 1-2: Power supply shown mounted correctly, with arrows pointing upward.....	16
Fig. 1-3: View from top right, showing power input and power switch.....	18
Fig. 1-4: Left and right side views.....	19
Fig. 1-5: Left side port panel, showing inputs for transducer (top) and monitor line-in (middle).....	20
Fig. 1-6: Right side power panel, showing power cable input and power switch.....	20
Fig. 1-7: Power label instructions.....	20
Fig. 1-8: AC adapter label indicating proper orientation on pole stand.....	20
Fig. 1-9: Standard patient line, from transducer to monitor to Argos.....	21
Fig. 1-10: Transducers connected to Argos and bedside patient monitor.....	22
Fig. 2-1: The Add Patient Data screen.....	24
Fig. 2-2: The Trend Screen.....	25
Fig. 2-3: Parameter settings.....	26
Fig. 2-4: Trend settings.....	27
Fig. 2-5: Tabular view.....	27
Fig. 2-6: The Tabular View tab.....	28
Fig. 2-7: Use a fingertip to drag upward from the bottom of the Trend screen.....	28
Fig. 2-8: Touch Switch to Tabular view on the user menu.....	29
Fig. 2-9: The Trend View tab.....	29
Fig. 2-10: Use a fingertip to drag downward from the top of the Tabular View.....	30
Fig. 2-11: Touch Switch to Trend View on the user menu.....	30
Fig. 2-12: Trend values shown on trends.....	31
Fig. 2-13: Status bar and control bar shown highlighted.....	31
Fig. 2-14: Control bar elements.....	31
Fig. 2-15: Status bar elements.....	32
Fig. 2-16: Transducer.....	33
Fig. 2-17: Left side view, showing bedside patient monitor and transducer inputs.....	33
Fig. 2-18: Initial setup screen: Add Patient Data.....	34
Fig. 2-19: Touch Use Previous Patient.....	35
Fig. 2-20: Verify previous patient information is correct.....	35
Fig. 2-21: Press OK to save and continue entering data.....	36
Fig. 2-22: Select from the Gender drop down.....	36
Fig. 2-23: Use the virtual keypad to enter numeric values.....	37
Fig. 2-24: Save entered data and proceed.....	37
Fig. 2-25: Search for Patient Record (Corepoint).....	38
Fig. 2-26: Search for patient record continued.....	38
Fig. 2-27: Verifying patient record.....	39
Fig. 2-28: Select BP Signal Source.....	39
Fig. 2-29: Select Transducer and then press Next.....	40
Fig. 2-30: The Zero transducer screen.....	41
Fig. 2-31: Press finish to begin patient monitoring.....	41
Fig. 2-32: The Trend screen.....	42
Fig. 2-33: Press any parameter label to change the displayed trend.....	43
Fig. 2-34: Tap the current trend name inside the box to change it.....	43

Fig. 2-35: The drop down list of trends.....	43
Fig. 2-36: MAP selected. Press Save to continue.....	44
Fig. 2-37: MAP displayed.....	44
Fig. 2-38: Touch the label to access Parameter settings.....	45
Fig. 2-39: "Show % change" shown highlighted.....	45
Fig. 2-40: Percentage change is measured from the flagged event.....	46
Fig. 2-41: "Show CI" selection box highlighted.....	47
Fig. 2-42: The Color selector.....	47
Fig. 2-43: Color selection.....	48
Fig. 2-44: SV trend and label displayed in blue.....	48
Fig. 2-45: High limit adjuster in Parameter settings.....	49
Fig. 2-46: CO upper alert limit reached.....	49
Fig. 2-47: A fingertip touching the MAP trend brings up a gray triangle.....	50
Fig. 2-48: Closer view of trend and label.....	50
Fig. 2-49: Arrows at both ends of the trend indicate an earlier view.....	50
Fig. 2-50: Draw two fingertips together to compress the time scale.....	51
Fig. 2-51: All three trends are lengthened to approximately one hour.....	51
Fig. 2-52: Time scale is 30 minutes before manual adjustment.....	52
Fig. 2-53: Time scale is shown on Trend settings.....	52
Fig. 2-54: Time scale intervals range from 10 minutes to 12 hours.....	53
Fig. 2-55: Set MAP graph range values here.....	53
Fig. 2-56: MAP trend settings with max graph value selector highlighted.....	54
Fig. 2-57: Max graph range value is now 140 mL.....	54
Fig. 2-58: Press Reset all trend options to return settings to defaults.....	55
Fig. 2-59: Tabular View.....	55
Fig. 2-60: Tap the desired interval.....	56
Fig. 2-61: Data is now shown in 30-minute intervals.....	56
Fig. 2-62: Touch the double arrow to rewind or fast-forward data.....	57
Fig. 2-63: Data rewound to start of monitoring session.....	57
Fig. 2-64: Drag leftwards for later values.....	57
Fig. 2-65: Drag rightwards for earlier values.....	58
Fig. 2-66: Control Bar elements.....	58
Fig. 2-67: Status Bar elements.....	58
Fig. 2-68: Touch the three-lined User Menu navigation icon to access it.....	60
Fig. 2-69: The User Menu.....	61
Fig. 2-70:End Session confirmation screen.....	61
Fig. 2-71: Re-zero transducer screen.....	62
Fig. 2-72: Tap the Export box.....	62
Fig. 2-73: Confirm shutdown.....	63
Fig. 2-74: About screen (Licensed versions).....	64
Fig. 2-75: EMR software licenses have expired.....	64
Fig. 2-76: The Settings menu, top.....	65
Fig. 2-77: The Settings menu, bottom.....	65
Fig. 2-78: Reset to default configuration selector.....	66
Fig. 2-79: Confirm reset to defaults.....	66
Fig. 2-80: The Settings menu (during patient monitoring session).....	67

Fig. 2-81: Tap the flag icon to notate or recall events.....	68
Fig. 2-82: Event marking screen, with Mark Event selected.....	68
Fig. 2-83: Description of event.....	69
Fig. 2-84: The Event History tab.....	69
Fig. 2-85: Edit event.....	70
Fig. 2-86: Press cancel to recall the Trend screen.....	70
Fig. 2-87: Press cancel to end assessment and go back to trend screen.....	71
Fig. 2-88: Press the fluid bolus icon to start the challenge.....	72
Fig. 2-89: Select between the two bolus sizes.....	72
Fig. 2-90: Argos prompts to create new baseline.....	73
Fig. 2-91: Press Next to create new baseline.....	73
Fig. 2-92: 3 minute timer countdown to create baseline for bolus fluid assessment.....	74
Fig. 2-93: Begin 250ml or 500ml Bolus infusion.....	74
Fig. 2-94: 7 minute timer countdown for a 250ml bolus.....	75
Fig. 2-95: 12 minute timer countdown for a 500ml bolus.....	75
Fig. 2-96: Report shows that patient is not likely fluid responsive.....	76
Fig. 2-97: Dynamic Assessment, PLR icon located on the Control Bar.....	76
Fig. 2-98: Instruction screen to prepare patient for PLR assessment.....	77
Fig. 2-99: 3 minute countdown timer to measure baseline for PLR assessment.....	77
Fig. 2-100: Instruction screen to inform the user to raise patient's legs by 45°.....	78
Fig. 2-101: PLR challenge screen which takes no more than 3 minutes.....	78
Fig. 2-102: PLR challenge screen reports that patient is likely fluid responsive.....	79
Fig. 2-103: Argos lets user know that the baseline is unstable.....	79
Fig. 2-104: Argos gives the user the option to use the existing baseline or to create a new one.....	80
Fig. 2-105: Argos prompts user to manually create new baseline.....	80
Fig. 2-106: Baseline rejected due to invalid samples.....	81
Fig. 2-107: Monitor prompts user that it's baseline has expired since their baseline is over 15 minutes old.....	81
Fig. 2-108: Dynamic Assessment History Icon can be found on the Control Bar.....	82
Fig. 2-109: Dynamic Assessment History performed during this session.....	82
Fig. 2-110: Dynamic Assessment History entry expanded to show more details.....	83
Fig. 2-111: EMR indicator.....	84
Fig. 2-112: EMR connectivity details.....	85
Fig. 2-113: No BP signal detected warning.....	86
Fig. 3-1: Add Patient Data screen with Search for Patient Record.....	88
Fig. 3-2: Patient record search.....	88
Fig. 3-3: Press Search after typing in the patient record.....	88
Fig. 3-4: Patient record located.....	89
Fig. 3-5: Verifying patient details with the EMR server.....	89
Fig. 3-6: Add patient weight and height, then press Save.....	90
Fig. 3-7: Patient demographics loaded, ready to proceed with monitoring.....	90
Fig. 3-8: Patient verification failed.....	91
Fig. 4-1: Touch Unlock to open Advanced Settings.....	92
Fig. 4-2: Confirm the user is qualified to change Advanced Settings.....	92
Fig. 4-3: Advanced settings, top of screen.....	93

Fig. 4-4: Press Unlock to access Advanced Settings.....	93
Fig. 4-5: Confirm access to Advanced Settings.....	94
Fig. 4-6: Press Manage to verify EMR status.....	94
Fig. 4-7: License Manager display of licensed device information	94
Fig. 4-8: Installed license not found.....	95
Fig. 4-9: License ready for installation from USB drive.....	95
Fig. 4-10: Press Import New License	96
Fig. 4-11: Software license successfully imported.....	96
Fig. 4-12: License information displayed in License Manager.....	97
Fig. 4-13: Selecting the Philips Monitor Connection.....	98
Fig. 4-14: Connection Status for Philips Monitor Showing no FG-009 Connected.....	98
Fig. 4-15: Connection Status for Philips Monitor Showing Full Functionality.....	99
Fig. 4-16: Select Network/Edit.....	99
Fig. 4-17: Automatic (DHCP) addressing shown selected.....	100
Fig. 4-18: Move the slide to switch off DHCP.....	100
Fig. 4-19: Sample DHCP values filled in.....	100
Fig. 4-20: Use the keyboard to enter network values.....	101
Fig. 4-21: Network settings.....	101
Fig. 4-22: Select EMR/Edit.....	102
Fig. 4-23: The EMR Settings screen.....	103
Fig. 4-24: Capsule server shown selected.....	103
Fig. 4-25: Enter EMR server information.....	104
Fig. 4-26: Edit Patient Record Server details.....	104
Fig. 4-27: Press Save to save and close EMR configuration.....	105
Fig. 4-28: Touch Update	105
Fig. 4-29: Select Install to proceed with the software upgrade.....	106
Fig. 4-30: Update complete, please remove the USB stick.....	106
Fig. 4-31: Press Shutdown to reboot the device.....	107
Fig. 4-32: About page showing the upgraded version	107
Fig. 4-33: No USB drive detected.....	108
Fig. 4-34: More than one USB drive detected	108
Fig. 4-35: No update file found.....	109
Fig. 5-1: Error message displayed, with null trend values.....	111
Fig. 6-1: Regression (unweighted Deming) plot for Retia Argos CO versus reference CO for all patients.....	120
Fig. 6-2: Regression (unweighted Deming) plot for predicate CO versus reference CO for all patients.....	121
Fig. 6-3: Bland-Altman plot comparing Retia Argos CO to reference CO for all patients. LOA [-3.52 to 3.47].....	122
Fig. 6-4: Bland-Altman plot comparing predicate CO to reference CO for all patients. LOA [-2.93 to 4.08].....	122
Fig. 6-5: Concordance plot for percentage changes in Retia Argos CO versus percentage changes in reference CO.....	123
Fig. 6-6: Concordance plot for percentage changes in predicate CO versus percentage changes in reference CO.....	124

Fig. 6-7: Regression (unweighted Deming) plots for Vigileo CO versus reference CO.
 Pearson's $r = 0.57$; Percentage within error grid = 49% 128

Fig. 6-8: Bland-Altman plot comparing Argos CO to reference CO. LOA [-3.43 to 4.93] 129

Fig. 6-9: Bland-Altman plot comparing Vigileo CO to reference CO. LOA [-4.28 to 4.74] 129

Fig. 6-10: Concordance plot for percentage changes in Argos CO versus percentage
 changes in reference CO 130

Fig. 6-11: Concordance plot for percentage changes in Vigileo CO versus percentage
 changes in reference CO 131

List of Tables

Table 1: Parameters, Definitions, and Units.....	2
Table 2: Device Labels Power Supply.....	12
Table 3: Standards compliance	14
Table 4: Battery icons	59
Table 5: Dynamic Assessment History Headers.....	83
Table 6: EMR status icons	84
Table 7: Troubleshooting error messages	110
Table 8: Physical and Mechanical Specifications	112
Table 9: Electrical Specifications	112
Table 10: Environmental Specifications	112
Table 11: Parameters	112
Table 12: Standards Compliance	113
Table 13 Argos Cardiac Output Monitor and Accessory Part Numbers.....	113
Table 14: Hemodynamic Parameters.....	114
Table 15: Technical Details for Dynamic Assessment.....	115
Table 16: Argos Monitor Defaults.....	115
Table 17: Summary statistics including bias, precision, normalized root mean squared error (NRMSE), concordance and root mean squared error for sub-group analyses.....	125
Table 18: Summary statistics including bias, precision, NRMSE and concordance for all data and subgroups. Note that concordance is not calculated for the subgroups due to restricted data	126

Intended Use

Indications for Use

The Argos Cardiac Output monitoring device is intended for use on patients above the age of 18. It is intended to be used as a hemodynamic monitor for continuously monitoring cardiac output and its derived parameters on patients in the intensive care unit or the operating room.

Intended Use

The Argos Cardiac Output monitor is used for the continuous measurement of cardiac output from an intravascular radial or femoral arterial blood pressure signal. This signal is derived from a blood pressure transducer or from the analog output of a vital signs monitor. The device is intended to be used by clinicians on critically ill patients in an operating room or in an intensive care unit.

**WARNING**

Read this manual carefully before attempting to use the Argos monitor.

**WARNING**

The Argos monitor is intended solely for use by qualified clinicians who have been trained in its use.

Contraindications

Use of the Argos monitor is contraindicated given: Any type of mechanical cardiac support – e.g., intra-aortic balloon pumps, left ventricular assist devices (LVADs); or Moderate to severe aortic valve regurgitation.

**WARNING**

The Argos monitor is not indicated for use with pediatric patients (age < 18).

**WARNING**

The Argos monitor should not be used to monitor arterial blood pressure. The arterial blood pressure transducer input on the Argos monitor is to be used only when another arterial blood pressure transducer is connected in parallel to a bedside patient monitor with the appropriate blood pressure alarms.

Not Intended as a blood pressure monitor

The Argos monitor is not intended to be used as a blood pressure monitor. The Argos monitor should be used only in conjunction with a bedside patient monitor connected to a radial or femoral artery. If the blood pressure transducer input is used to capture the arterial blood pressure signal, the transducer must be a second transducer connected in parallel with the bedside patient monitor arterial blood pressure transducer.

Parameters

Table 1: Parameters, Definitions, and Units

Parameter	Abbr.	Defined	Units
Cardiac Output	CO	The amount of blood the heart pumps through the circulatory system in a minute.	L/min
Cardiac Index	CI	The ratio of cardiac output to body surface area.	L/min/m ²
Mean Arterial Pressure	MAP	Average pressure in the arteries during a cardiac cycle.	mmHg
Heart rate	HR	Number of heartbeats per minute.	bpm
Blood pressure	BP	The arterial pressure of blood (systolic/diastolic)	mmHg
Stroke Volume	SV	The volume of blood pumped from the left ventricle per beat.	mL
Stroke Volume Index	SVI	The volume of blood pumped by the heart with each beat, divided by the body surface area.	mL/m ²
Systemic Vascular Resistance	SVR	The resistance to blood flow offered by all of the systemic vasculature, excluding the pulmonary vasculature.	dyne-s/cm ²
Systemic Vascular Resistance Index	SVRI	Systemic Vascular Resistance proportional to body size	dyne-s-m ² /cm ²
Pulse Pressure Variation*	PPV	The difference between maximum and minimum pulse pressure over a respiratory cycle, per mean pulse pressure	%

*PPV may not be calculated if the timing or morphology of the BP waveform does not conform to an expected morphology or timing used for pattern recognition. In this case PPV may not be calculated or displayed even though cardiac output numbers are still being calculated.

Pulse Pressure Variation

The monitor displays pulse pressure variation (PPV) calculated using the formula

$$PPV = \frac{(PP_{max} - PP_{min})}{(PP_{max} + PP_{min})/2} \times 100$$

where PP_{max} and PP_{min} are the maximum and minimum pulse pressures over a respiratory cycle. The respiratory period is based on the maximum amplitude of the power spectrum of the BP waveform within the frequency range corresponding to a periodicity of between 2 to 10 seconds. The PPV is displayed in 1% increments.

**WARNING**

Pulse Pressure Variation (PPV) is only valid in patients with closed chests on full control mode ventilation.

**WARNING**

Pulse Pressure Variation (PPV) is unreliable in patients with significant arrhythmia.

Warnings, Cautions, Notes, Symbols and Standards

This chapter describes the symbols that appear in the manual or on product labels, including those used to identify warnings, cautions, and notes. A list of all warnings and cautions used in this manual is provided here.

This chapter also includes a list of relevant standards to which the Argos monitor complies.

Warnings, Cautions and Notes

Warnings, **Cautions**, and **Notes** have particular meanings in this manual. **Warnings** and **Cautions** are placed inside a text box containing a caution triangle. Note the difference between a **Warning** and a **Caution**:



WARNING

Calls attention to situations or actions that could result in personal injury or death.



CAUTION

Calls attention to situations or actions that could damage equipment, produce inaccurate data, or invalidate a procedure.

Notes are offset from the left-hand margin and marked with an arrow:

- ▶ ***Notes relevant to the procedure being described are presented primarily in the clinical how-to section of the manual.***



WARNING

Misuse may be a hazard to the patient. Read all warnings and cautions in this section of the manual before using the Argos monitor.

At all times, the following warnings and cautions should be observed when using the Argos monitor:



WARNING

Do not use the Argos monitor if the monitor shows evidence of having been opened or tampered with. If the monitor shows signs of tampering, the monitor should be immediately returned to Retia for inspection. Please call Retia Medical customer support to report the issue and receive assistance.



WARNING

Read this manual carefully before attempting to use the Argos monitor.



WARNING

The Argos monitor is intended solely for use by qualified clinicians who have been trained in its use.

**WARNING**

The Argos monitor is not indicated for use with pediatric patients (age < 18).

**WARNING**

Severe, persistent arrhythmias may affect accuracy.

**WARNING**

Do not use the Argos monitor as a pulse rate or blood pressure monitor.

**WARNING**

The Argos monitor should *not* be used to monitor arterial blood pressure. The arterial blood pressure transducer input on the Argos monitor is to be used *only* when another arterial blood pressure transducer is connected in parallel to a bedside patient monitor with the appropriate blood pressure alarms.

**WARNING**

Pulse Pressure Variation (PPV) is only valid in patients with closed chests on full control mode ventilation.

**WARNING**

Pulse Pressure Variation (PPV) is unreliable in patients with significant arrhythmia.

**WARNING**

Do not use the Argos monitor if it is damaged. Please contact a representative to report this to Retia Medical.

**WARNING**

Do not use damaged system components.

**WARNING**

Do not attempt to use the Argos monitor if it is not fastened to a stand.

**WARNING**

During use, the Argos monitor should *never* be placed flat on a surface or balanced on a tabletop or other surface.

**WARNING**

The Argos monitor and power adapters must be positioned in an upright position to ensure IPX1 ingress protection.

**WARNING**

Do not position the external power supply in such a fashion that it is difficult to unplug the mains cord in case an emergency requires the monitor to be unplugged.



WARNING

The Argos monitor must be securely mounted. Ensure all cords and cables are placed so they pose no risk of injury to patients, users, or equipment.



WARNING

Ensure there is sufficient room for cables and transducer or monitor lines.



WARNING

To avoid potential fire hazard, if using a pole mount, make sure the power supply is placed on the pole so that the arrows on the label are pointing upward.



WARNING

Do not operate the Argos monitor outside operating specifications for temperature, humidity, and air pressure (see Appendix 5.1, Table A-3). Ensure the device is within operating specifications before use.



WARNING

Ensure there is adequate space around the unit to allow for proper ventilation.



WARNING

Explosion hazard! Do not use the Argos monitor in the presence of any flammable anesthetic mixture with air or with oxygen or nitrous oxide.



WARNING

The Argos monitor is intended solely for use with a radial or femoral arterial catheter. *Do not* attempt to use it with any other kind of patient connection.



WARNING

Do not place any foreign items (unapproved 60601-1 items) in any of the Argos monitor ports.



WARNING

Equipment that generates high energy, high frequency electromagnetic radiation should not be used in close proximity to this monitor or any other patient monitoring equipment.



WARNING

Do not position IEC/EN 60950 equipment, including printers, any closer than 1.5 meters to the patient's bed while the Argos is in use.



WARNING

Do NOT use the Argos monitor if signs of tampering are present. Contact a Retia Medical representative.



WARNING

Do not attempt to connect a power supply to the monitor that has not been approved for use by Retia Medical.

**WARNING**

To avoid the risk of electric shock, this equipment must only be connected to a supply mains with protective earth.

**WARNING**

Do not use extension cords or multiple socket devices to connect the power adapter.

**WARNING**

Do not connect the Argos monitor to a patient monitor using an AC or pulsed DC pressure transducer excitation voltages.

**WARNING**

The Argos *must* be used in conjunction with an approved bedside patient monitor.

**WARNING**

When using a transducer connected directly to the Argos monitor, make sure the transducer is leveled to the phlebostatic axis.

**WARNING**

Carefully inspect the radial or femoral arterial line before use.

**WARNING**

Do not use a transducer or catheter that is damaged or that has exposed electrical contacts.

**WARNING**

Before operating in conjunction with a bedside patient monitor, consult with a Retia Medical representative to ensure the monitor has compatible specifications.

**WARNING**

Do NOT use the Argos monitor in proximity to an MRI scanner.

**WARNING**

A hazard can exist if different alarm/alert presets are used for the same or similar equipment in any single area.

**WARNING**

Do not attempt to attach or connect a transducer, transducer line, monitor, or monitor line to the Argos monitor which has not been certified for use by Retia Medical.

**WARNING**

If the Argos monitor is connected directly to a transducer, the patient must also be simultaneously connected to the bedside patient monitor with another transducer via a 4-way stopcock.



WARNING

Shock or fire hazard! Do not immerse the Argos monitor or cables in any liquid solution. Do not allow any fluids to enter the instrument.



WARNING

Use of a damaged cable may result in inaccurate cardiac output measurements or may damage the Argos monitor.



WARNING

Use of accessories, sensors, lines, and cables other than those specified in this User Guide may result in increased emission and/or decreased immunity to electrical field interference of the Argos monitor.



WARNING

Only an experienced practitioner should insert the arterial line.



WARNING

The transducer, 4-way stopcock, and connecting pressure tubing are single-use only and should never be reused.



WARNING

Observe institutional guidelines for disposal of biohazard waste after use of transducer, 4-way stopcock, and connected pressure tubing.



WARNING

The Navigation section of this manual is intended solely to familiarize users with the Argos monitor. Do not operate the Argos monitor until the user has read Chapter 8 and pertinent warnings and cautions.



WARNING

The Argos monitor is intended only to supplement patient assessment, and must *only* be used in conjunction with a bedside patient monitor.



CAUTION

Do not expose the Argos monitor to extreme temperatures.



WARNING

Use of the Argos monitor is restricted to one patient at a time.



CAUTION

The Argos Monitor is a precision monitoring device and should not be subject to excessive mechanical shock that may affect its structural integrity. Do not drop the monitor when handling, and do not tip over, or slam, the roll stand into a stationary object when the monitor is attached.

Device Labels



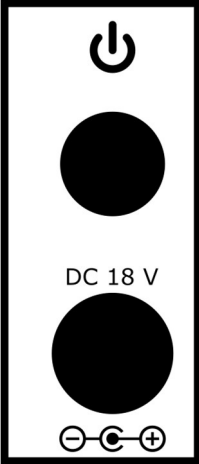
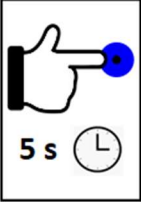

Image	Label	Description
	Silk-screened On Enclosure	Company logo
		Product ID
	Power label	Power input
		Power switch prompt (Hold for 5 seconds)
		Power switch
DC 18 V		Power specification
		Power cable port

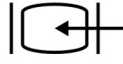

Image	Label	Description
	<p>Data I/O label</p>	<p>BP Transducer Input</p> <p>External monitor input</p> <p>Data I/O</p>
		<p>Bedside patient monitor line-in</p>
		<p>Transducer line-in</p>
<p>DATA EXP</p>		<p>Data export ports</p>

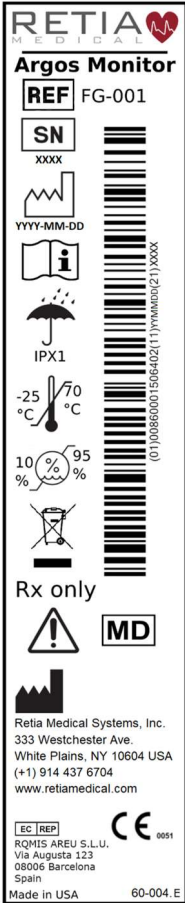







Image	Label	Description
	<p>UDI, Caution, and Company Contact label</p>	<p>Caution and Company Contact</p>
		<p>Part Number</p>
		<p>Serial Number</p>
		<p>Date of Manufacture</p>
		<p>Read Operators Manual</p>
		<p>IP rating</p>
		<p>Temperature limits</p>
		<p>Humidity limits (non-condensing)</p>
	<p>WEEE</p>	



Image	Label	Description
Rx only		Prescription Use Only
		Caution
		Manufacturer
 <p> CONFORMS TO AAMI STD ES60601-1 IEC STD 60601-1 IEC STD 60601-1-6 IEC STD 62304 IEC STD 60601-2-34 CERTIFIED TO CSA STD C22.2 # 60601-1 </p>	ETL label	Lists standards to which Argos monitor complies

Table 2: Device Labels Power Supply

	Power supply label	Arrows indicate correct placement of power supply on pole mount
--	--------------------	---

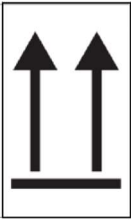

WARNING

Do not use the Argos monitor if it is damaged. Please contact a representative to report this to Retia Medical.



WARNING

Do not use damaged system components.

Shipping Label



Retia Medical System, Inc.
333 Westchester Avenue
White Plains, NY 10604
United States

EC REP

RQMIS AREU S.L.U.
Barcelona Health Hub
Carrer de Sant Antoni Maria
Claret 167.
Barcelona 08025
Spain

CH REP

Casus Switzerland GmbH
Hinterbergstrasse 49
6312 Steinhausen
Switzerland

UKRP

UK Responsible Person
RQMIS AR Ltd.
4 Whitan Way Whitney,
Oxfordshire OX28 6FF,
United Kingdom

Argos

Cardiac Output Monitor

RETIA

M E D I C A L



(01)00860001506402(11)YYMMDD(21)XXXX

REF FG-001

SN



Rx only

MD

10% 95%
-25 °C 70 °C



IPX1



retia.ai/manuals

CE 0051



Cardiac Output Monitor
Monitor de gasto cardíaco
Moniteur de débit cardiaque
Monitor des Herzzeitvolumens
Monitor della gittata cardiaca
Monitor de débito cardíaco
Monitor for hjerteminutvolumen
Hartminuutvolume-monitor
Monitor för hjärtminutvolym
Παρακολουθητής καρδιακής παροχής
Monitor for hjerteminuttvolum
Sydämen minuuttitilavuusmonitori

60-012.G

Fig. 1: Device Shipping Label

Standards Compliance

Applied Part Type	1x Type CF defibrillation-proof
Equipment class	Class II
Electrical Protection Class	IEC Class I
Ingress Protection Class	IPX1
IEC Standards	IEC 60601-1:2005+AMD1:2012
	IEC 60601-1-2:2014
	IEC 60601-2-34:2011*
	IEC 60601-1-8: 2011 IEC 62366-1:2015
Packaging standard	2A

Table 3: Standards compliance

**Not including the section (208.6) on alarms. All alarms are governed by IEC 60601-1-8.*

1 Initial Setup

1.1 Mounting the Argos

**WARNING**

Do not attempt to use the Argos monitor if it is not fastened to a stand.

**WARNING**

During use, the Argos monitor should *never* be placed flat on a surface or balanced on a tabletop or other surface.

The Argos Cardiac Output Monitor is designed to be operated while fastened to a stand – for example, a standard pole mount or table stand. It complies with 75mm square screw patterns and 100mm square screw patterns which require M4 screws that extend 7-7.5mm into the monitor, not including the thickness of the VESA mounting plate. Retia recommends 10mm M4 screws for a 2.5mm thick mounting plate and 8mm M4 screws for a 1mm thick mounting plate. (For particular mounting solutions, please contact Retia Medical at 914-437-6704 , or at info@retiamedical.com.)

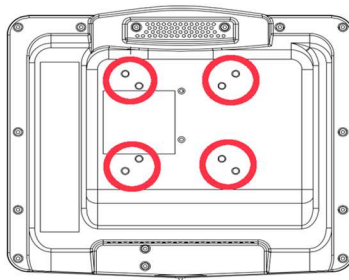



Fig. 1-1: Rear view, showing mount holes

When using the Argos monitor with a pole mount, the AC supply **must** be positioned so that the arrows on the label on the power supply are pointing upward, as shown below.





Fig. 1-2: Power supply shown mounted correctly, with arrows pointing upward

- 

WARNING
The Argos monitor and power adapters must be positioned in an upright position to ensure IPX1 ingress protection.
- 

WARNING
Do not position the external power supply in such a fashion that it is difficult to unplug the mains cord in case an emergency requires the monitor to be unplugged.
- 

WARNING
The Argos monitor must be securely mounted. Ensure all cords and cables are placed so they pose no risk of injury to patients, users, or equipment.
- 

WARNING
Ensure there is sufficient room for cables and transducer or monitor lines.
- 

WARNING
To avoid potential fire hazard, if using a pole mount, make sure the power supply is placed on the pole so that the arrows on the label are pointing upward.

**WARNING**

Do not operate the Argos monitor outside operating specifications for temperature, humidity, and air pressure (see Section 5.1, Table 8-3). Ensure the device is within operating specifications before use.

**WARNING**

Ensure there is adequate space around the unit to allow for proper ventilation.

**WARNING**

Explosion hazard! Do not use the Argos monitor in the presence of any flammable anesthetic mixture with air or with oxygen or nitrous oxide.

**WARNING**

The Argos monitor is intended solely for use with a radial or femoral arterial catheter. *Do not* attempt to use it with any other kind of patient connection.

**CAUTION**

Do not expose the Argos monitor to extreme temperatures.

**CAUTION**

Grasp the connector – not the cable – when connecting or disconnecting a cable or line.

**CAUTION**

Do not twist or bend the connectors.

**WARNING**

Do not place any foreign items (unapproved 60601-1 items) in any of the Argos monitor ports.

**WARNING**

Equipment that generates high energy, high frequency electromagnetic radiation should not be used in close proximity to this monitor or any other patient monitoring equipment.

**WARNING**

Do not position IEC/EN 60950 equipment, including printers, any closer than 1.5 meters to the patient's bed while the Argos is in use.

**CAUTION**

Since BP waveforms may be affected by the use of electrosurgical units, distance electrocautery equipment and cables from the Argos monitor and plug the power cords into separate AC circuits. Should signal quality problems persist, call Retia Medical for assistance.



CAUTION

Regularly inspect all cables for defects. Never coil cables tightly while using, or when storing.



CAUTION

If any electrolytic solution such as NaCl, Lactated Ringers, is allowed to contact the cable connectors while connected to the Argos monitor, and the monitor is turned on, the excitation voltage may cause electrolytic corrosion and rapid degradation of the electrical contacts. Therefore, do not allow electrolytic solutions to contact the cable connectors.



CAUTION

Portable and mobile RF communication equipment can potentially affect all electronic medical equipment, including the Argos monitor. Guidance on maintaining appropriate separation between communications equipment and the Argos monitor is provided in the Manufacturer's Declaration of Conformity Electronic Emissions and Immunity on page i.



CAUTION

The sole function of the Argos monitor's data export ports is to export data. Do not attempt to use the data export ports for any other purpose.

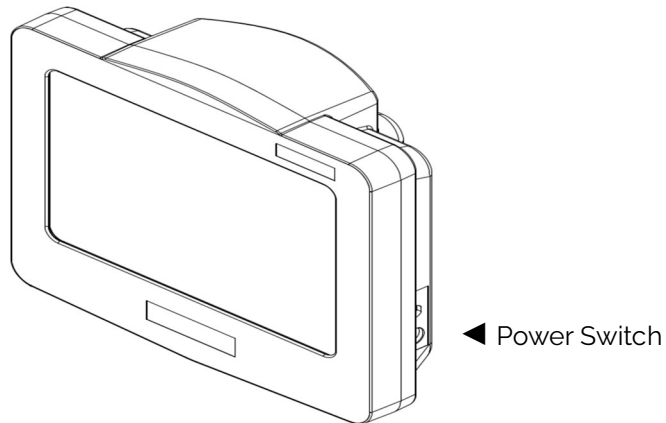

Fig. 1-3: View from top right, showing power input and power switch

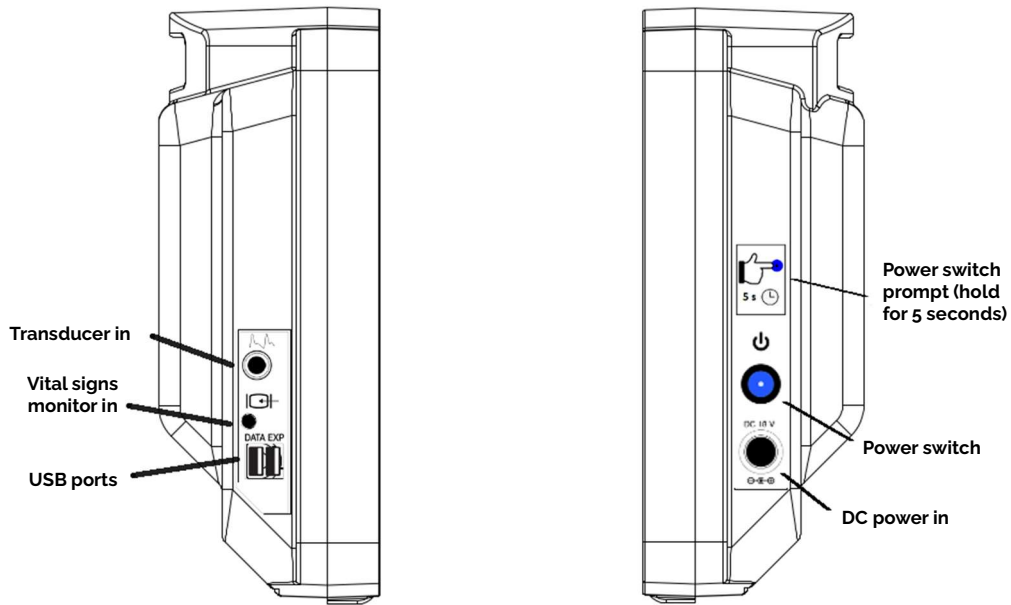

Fig. 1-4: Left and right side views

Before use, ensure the Argos Monitor has not been tampered with by insuring the tamperproof stickers are intact on the side of the monitor. If signs of tampering are present, contact Retia Medical for assistance.



WARNING

Do NOT use the Argos monitor if signs of tampering are present. Contact a Retia Medical representative.



WARNING

Do not attempt to connect a power supply to the monitor that has not been approved for use by Retia Medical.



WARNING

To avoid the risk of electric shock, this equipment must only be connected to a supply mains with protective earth.

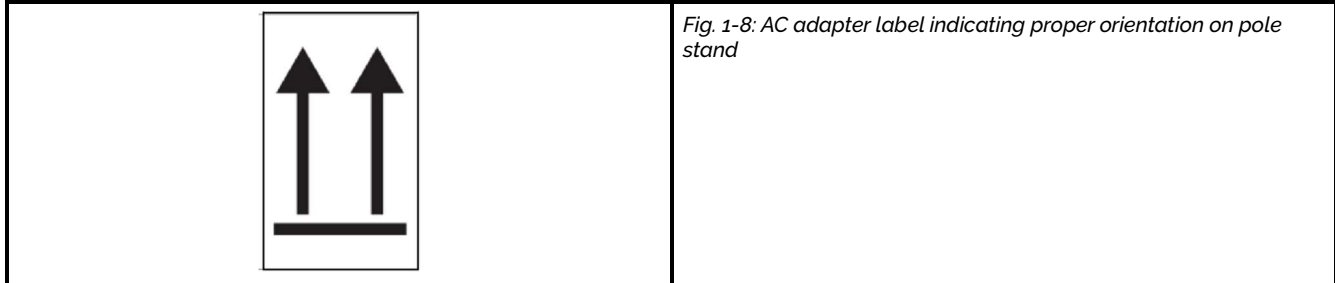
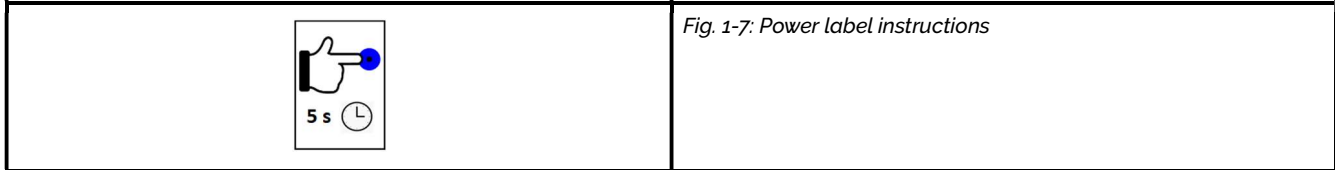
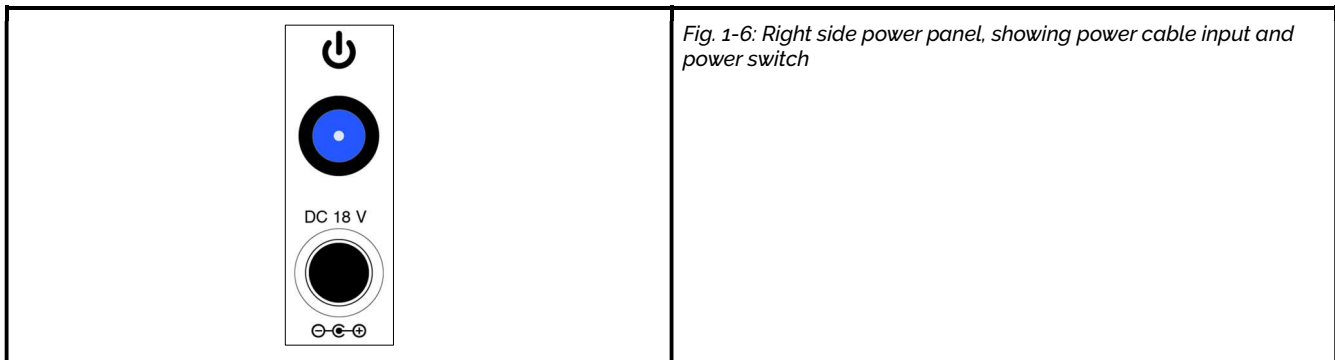
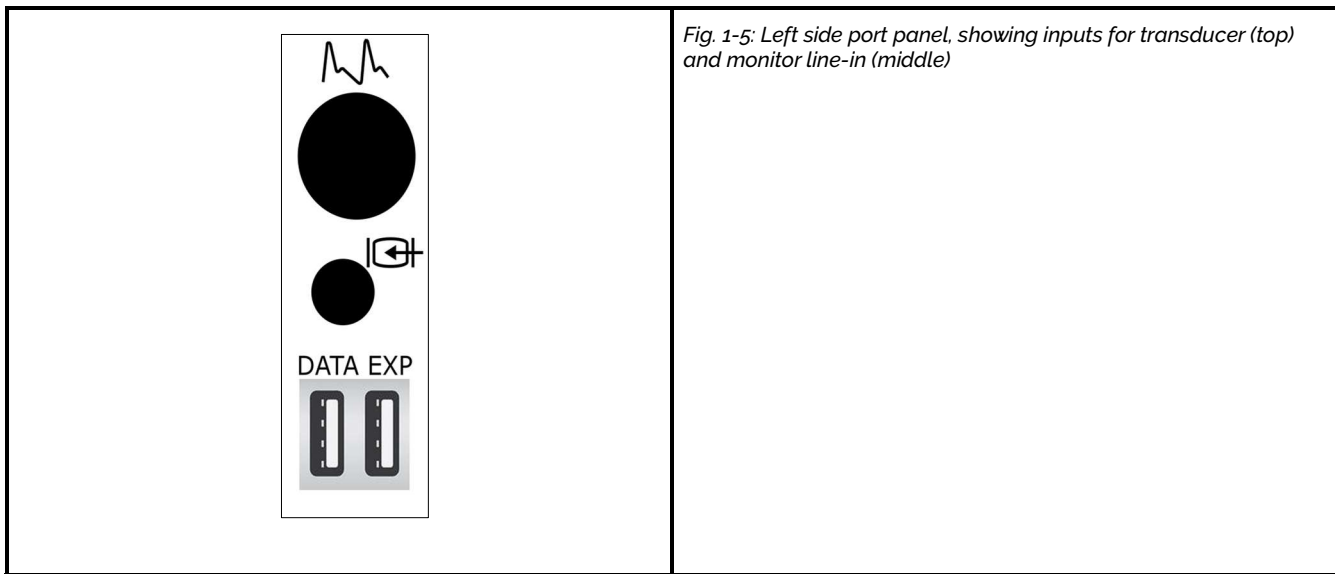

	<p>WARNING Do not use extension cords or multiple socket devices to connect the power adapter.</p>
---	---

	<p>WARNING Do not connect the Argos monitor to a patient monitor using an AC or pulsed DC pressure transducer excitation voltages.</p>
---	---

**CAUTION**

The Argos monitor is intended for operation while plugged into an AC wall outlet. Although it will continue to function at full capacity on battery power alone, such as when an emergency power outage occurs, it is **not** designed for cordless use. In case of a power outage, use of the Argos monitor should be terminated as soon as feasible.

Plug the power cable into a working AC power outlet. Connect the cable to the DC power in socket of the monitor.

**WARNING**

The Argos *must* be used in conjunction with an approved bedside patient monitor.

**WARNING**

When using a transducer connected directly to the Argos monitor, make sure the transducer is leveled to the phlebostatic axis.

**WARNING**

Do not place any foreign items (unapproved 60601-1 items) in any of the Argos monitor ports.

The Argos must be connected either directly to a transducer from a radial or femoral artery catheter, or to a bedside patient monitor.

**WARNING**

Carefully inspect the radial or femoral arterial line before use.

**WARNING**

Do not use a transducer or catheter that is damaged or that has exposed electrical contacts.

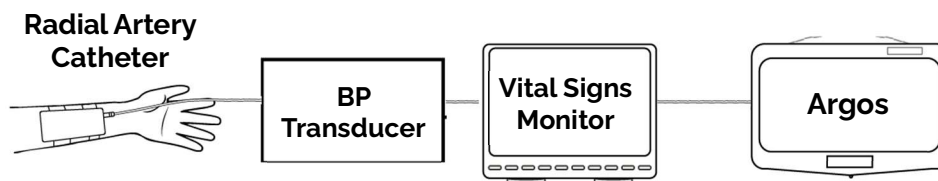



Fig. 1-9: Standard patient line, from transducer to monitor to Argos

The patient should be fitted with a radial or femoral arterial catheter.

If, as in Fig. 1-9 above, the transducer is connected to a bedside patient monitor, the Argos connects to a line from the monitor.

The Argos monitor is designed for use with a bedside patient monitor analog output with a range of 0-3V and a scale 1V=100mmHg.

 **WARNING**
 Before operating in conjunction with a bedside patient monitor, consult with a Retia Medical representative to ensure the monitor has compatible specifications.

 **WARNING**
 Do NOT use the Argos monitor in proximity to an MRI scanner.

 **CAUTION**
 Following exposure to defibrillation voltage, the Argos monitor recovers within 10 seconds.

 **WARNING**
 A hazard can exist if different alarm/alert presets are used for the same or similar equipment in any single area.

 **WARNING**
 Do not attempt to attach or connect a transducer, transducer line, monitor, or monitor line to the Argos monitor which has not been certified for use by Retia Medical.

If a transducer is connected directly to Argos, as in Fig. 1-10, another transducer must be connected to the bedside patient monitor, for example with a 4-way stopcock.

 **WARNING**
 If the Argos monitor is connected directly to a transducer, the patient must also be simultaneously connected to the bedside patient monitor with another transducer via a 4-way stopcock.

Detailed setup instructions are at §2.4.1 page 32.

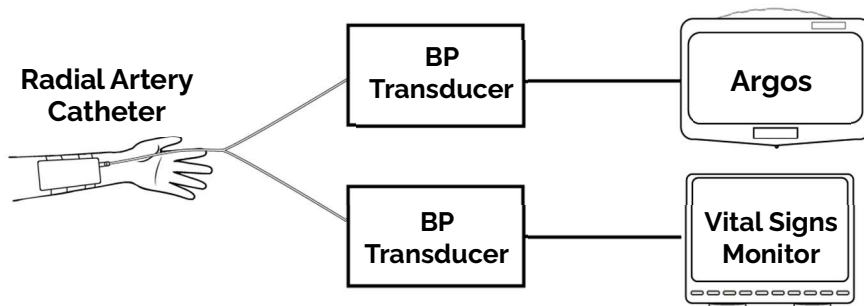



Fig. 1-10: Transducers connected to Argos and bedside patient monitor

 **WARNING**
 Shock or fire hazard! Do not immerse the Argos monitor or cables in any liquid solution. Do not allow any fluids to enter the instrument.

 **WARNING**
 Use of a damaged cable may result in inaccurate cardiac output measurements or may damage the Argos monitor.

**WARNING**

Use of accessories, sensors, lines, and cables other than those specified in this User Guide may result in increased emission and/or decreased immunity to electrical field interference of the Argos monitor.

**WARNING**

Only an experienced practitioner should insert the arterial line.

**WARNING**

The transducer, 4-way stopcock, and connected pressure tubing are single-use only and should never be reused.

**WARNING**

Observe institutional guidelines for disposal of biohazard waste after use of transducer, 4-way stopcock, and connected pressure tubing.

If the user is connecting a transducer directly to the Argos monitor, use only the transducer specified by Retia Medical.

To power on, press and hold the power button for 5 seconds. The indicator on the power button will light up blue, signaling that the device has been switched on.

2 Using the Argos Monitor

The Argos Cardiac Output Monitor provides quick access to blood pressure monitoring and derived parameters through a rapidly configurable touch screen interface. The next section introduces the user to the basic screens; following chapters offer step-by-step instructions for using the Argos. Please take care to observe **Cautions** and **Warnings** (boxed text marked by an exclamation point set off in a yellow triangle) and helpful notes (▶).



WARNING

The Argos monitor *does not* alarm upon detection of low MAP. Such notifications are a function of the bedside patient monitor.



WARNING

The Argos monitor is intended only to supplement patient assessment, and must *only* be used in conjunction with a bedside patient monitor.

2.1 Guide to screens

The Argos is operated by entering information and accessing options through a touchscreen interface. Use a fingertip to select data and quickly move through screens. The interface has three primary modes: Setup, Trend Screen, and Tabular View.

The **Setup screen** is used to enter patient information at the beginning of each new session.

Fig. 2-1: The Add Patient Data screen

The **Trend Screen**, showing three trends, each identified by the parameter label field, or label, to the right.

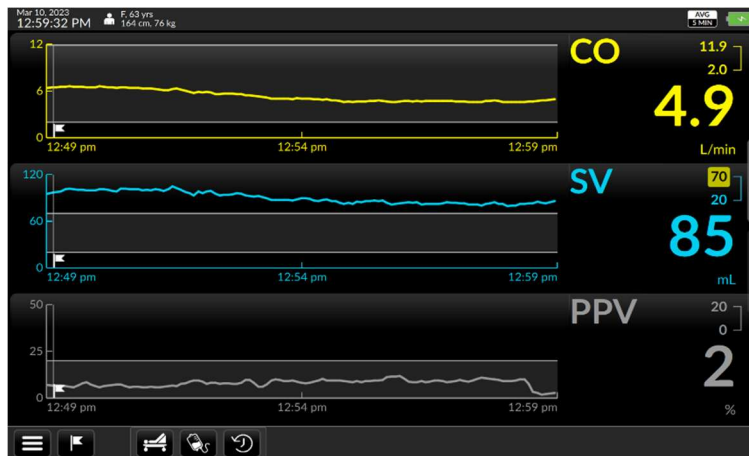

Fig. 2-2: The Trend Screen

All three trends are user-selectable. Prior monitoring session trends can be accessed via fingertip control and coordinates scaled across either axis. The parameter label field can show quantitative indices, values or changes, and allows adjustment of alert limits. Examples below offer a closer look:

Each label shows the parameter name, alert limits, and, in larger characters, current numeric value.



Optionally, a label can show a percentage change (see §2.8.2 page 45) since the last event created, or from monitoring initiation, if no event has been created.



Some parameters can be configured to show an associated index or value.

Here, stroke volume (SV) displays below the Stroke Volume Index (SVI) label.

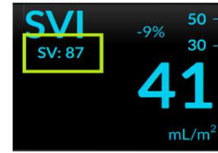

The numbers connected by the brace in the upper right corner are high and low alert limits, which are user-configurable.

Should the value of the parameter exceed either limit, the limit will show against a yellow background for as long as the value is beyond the selected threshold.



Touching the parameter label brings up the **Parameter Settings** overlay. Here the user can select a new parameter, or add, remove, or change the way a parameter is displayed, including colors and alert thresholds.

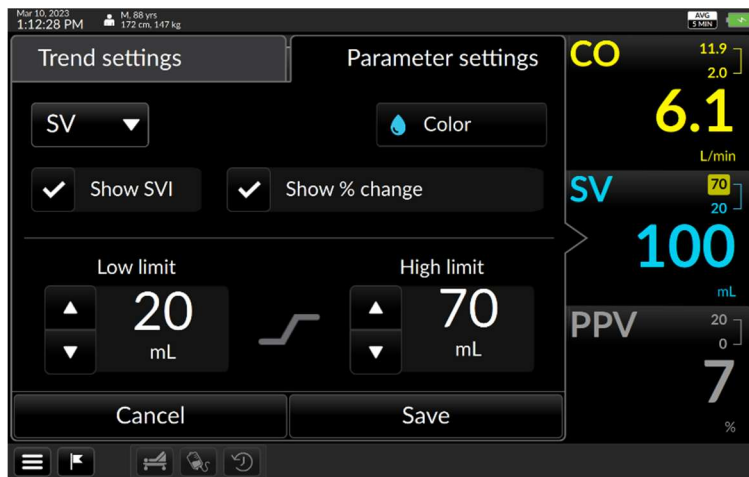

Fig. 2-3: Parameter settings

Touching the trend display summons **Trend Settings**, which allows for adjusting the trend graph, both the trend (Y-axis) value, and the time coordinate (X-axis).

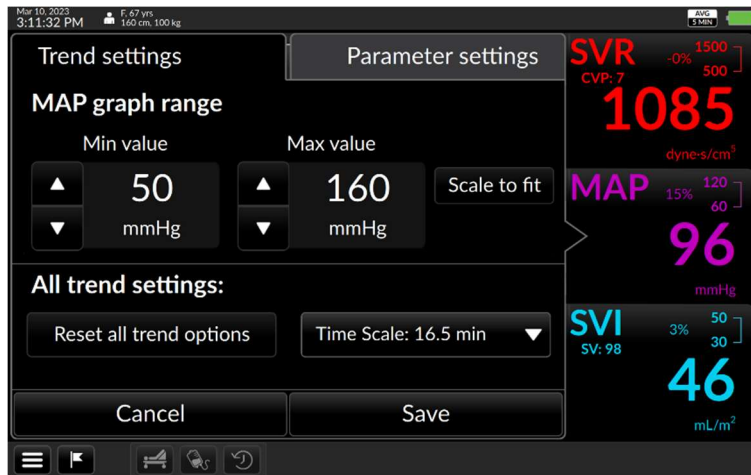

Fig. 2-4: Trend settings

The **Tabular View** screen displays continuously measured values in intervals of 15 minutes, 30 minutes, 1 hour or 2 hours.

Time	9:24 AM	5:30 PM	5:45 PM	6:00 PM	6:15 PM	6:30 PM	6:45 PM
CO L/min	5.6	4.7	6.4	5.3	5.0	4.6	6.5
CI L/min/m ²	2.6	2.2	3.0	2.5	2.3	2.2	3.0
SV mL	96	86	98	94	85	83	100
SVI mL/m ²	45	40	46	44	40	39	47
SVR dyne-s/cm ³	1090	1122	1077	1074	1195	1151	1086
SVRI dyne-s-m ² /cm ³	2325	2394	2297	2290	2549	2455	2316
PPV %	2	10	7	5	3	9	7

Fig. 2-5: Tabular view

Access the Tabular view screen in one of three ways:

- 1) Touch the "Tabular View" tab located on the right side of the Trend Screen

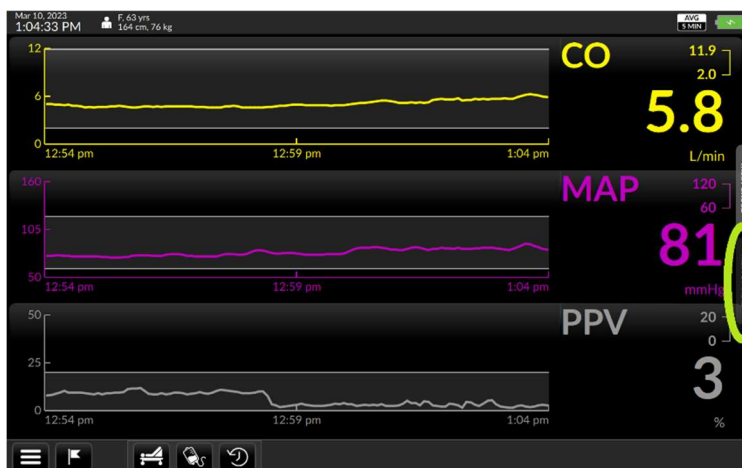

Fig. 2-6: The Tabular View tab

- 2) Drag upward with one finger from the bottom of the Trend Screen



Fig. 2-7: Use a fingertip to drag upward from the bottom of the Trend screen

- Tap the User Menu navigation icon at the bottom left of the screen (see §2.11.2, p. 60) and select "Switch to Tabular View"

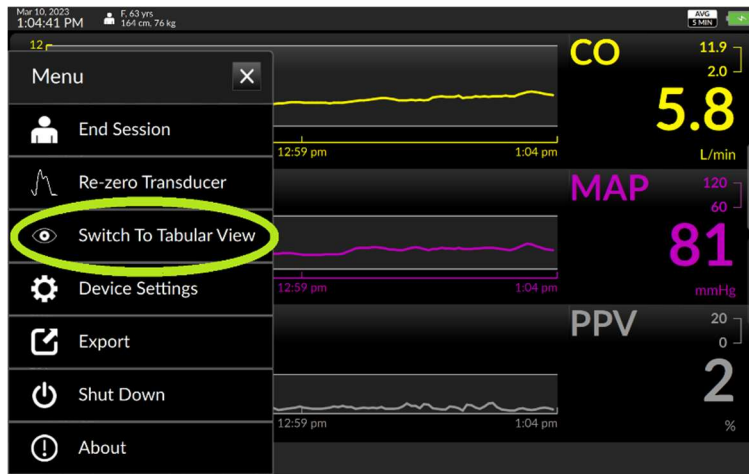

Fig. 2-8: Touch Switch to Tabular view on the user menu

To return to the Trend Screen from Tabular View:

- Touch the "Trend View" tab located on the right side of the Tabular screen



Fig. 2-9: The Trend View tab

Or 2) drag downward with one finger from the top of the Tabular View screen

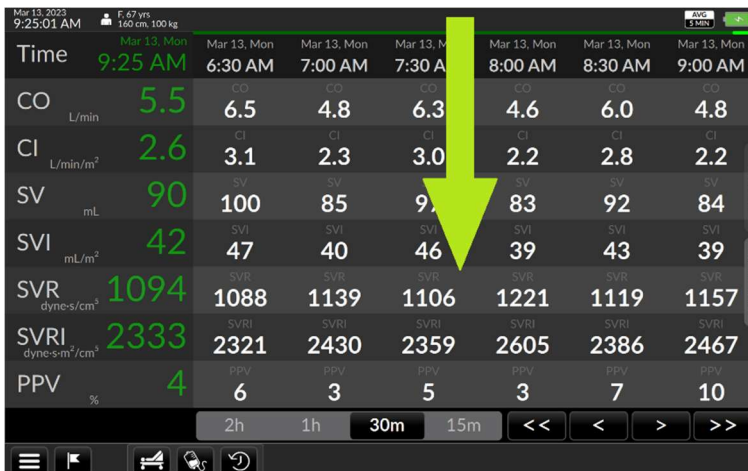

Fig. 2-10: Use a fingertip to drag downward from the top of the Tabular View

Or 3) tap the User Menu navigation icon at the bottom left of the screen (see §2.11.2, p. 60) and select "Switch to Trend View"

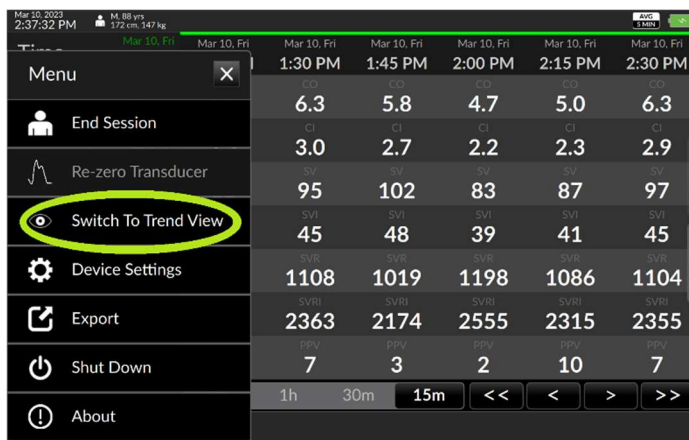

Fig. 2-11: Touch Switch to Trend View on the user menu

2.2 Trend Scrubbing

Dragging a fingertip along a waveform activates the “scrubbing” function, which pops up the numeric value of the trend at the particular moment. Place your finger on the trend plot to initiate this:



Fig. 2-12: Trend values shown on trends

2.3 The Control Bar & Status Bar

A number of options and settings can be accessed via the **status bar** and the **control bar** which is always visible at the top and bottom of the display.

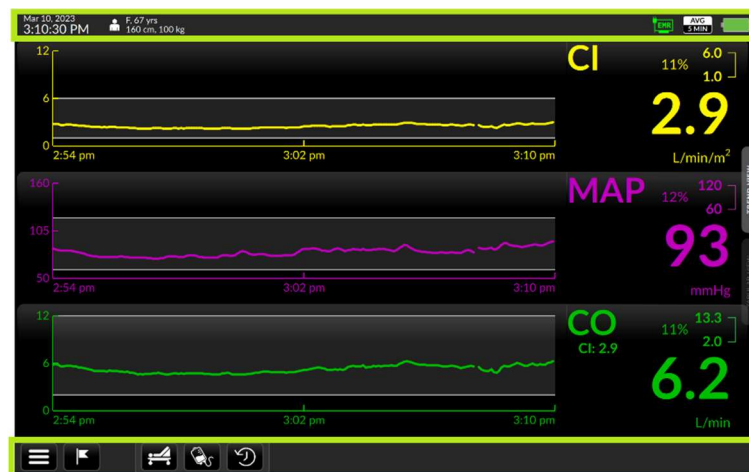

Fig. 2-13: Status bar and control bar shown highlighted

The control bar contains the menu icon, allowing access to important functions. The Control Bar selection offers access to Event marking and Dynamic Assessment functionality. Dynamic Assessment functionality includes Passive Leg Raise (PLR) and fluid bolus challenge and the Dynamic Assessment History.

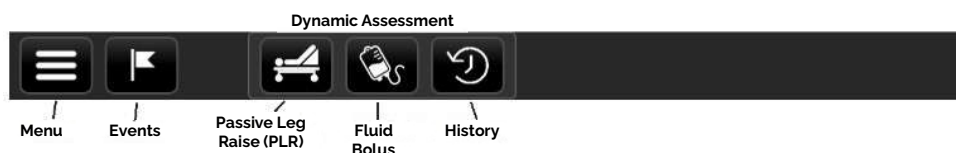

Fig. 2-14: Control bar elements

While the Argos is monitoring, the status bar displays patient information, date and time, monitor mode of operations and a battery icon showing the power state. EMR status is shown when this feature is enabled by a software license.



Fig. 2-15: Status bar elements

2.4 The Setup Screens

2.4.1 Prepare patient

Make sure the patient has been readied for monitoring.

If using a signal from a bedside patient monitor: connect it to the designated port in the patient monitor. Then, proceed to §2.5, *Initial setup – Input patient data*.

If using direct connection to a transducer cable: Utilize a BP Transducer Kit (P/N 902-649) and a Transducer Interface Cable (P/N FG-015) to connect directly to the Argos monitor.

To order these accessory parts, please contact Retia customer support or a Retia representative.

Use a 4-way stopcock to connect the patient to a bedside patient monitor and the Argos monitor simultaneously.



WARNING

When using a transducer connected directly to the Argos monitor, make sure the transducer is leveled to the phlebostatic axis.



WARNING

The Argos monitor must only be used with a radial or femoral arterial catheter. Do not attempt to use the device with any other type of catheter.



WARNING

The BP Transducer Kit (P/N 902-649) and Transducer Interface Cable (P/N 650-299-117) are indicated for use with the Argos Monitor. No other parts should be substituted for these approved accessories.

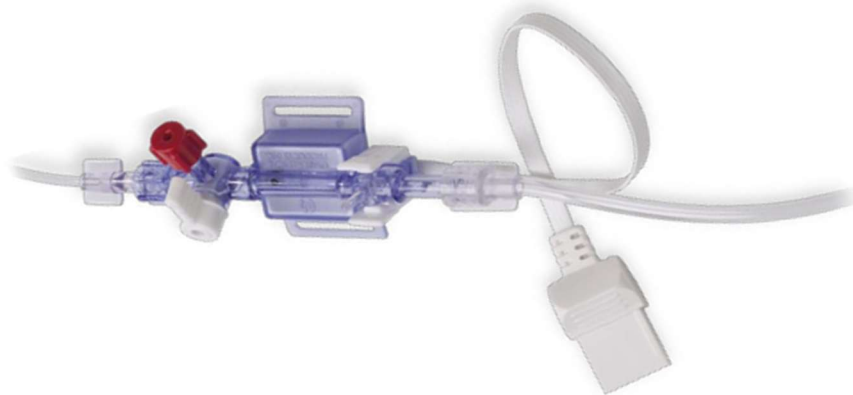

Fig. 2-16: Transducer

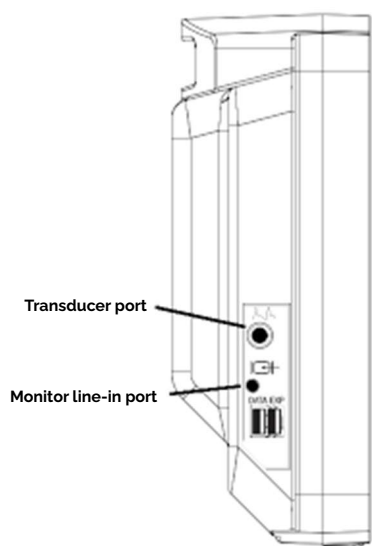

Fig. 2-17: Left side view, showing bedside patient monitor and transducer inputs

Once the patient has been fitted with a radial or femoral arterial catheter: Connect the arterial catheter output line to the 4-way stopcock provided within the BP Transducer Kit (P/N 902-649).

1. Connect the transducer provided with the BP Transducer Kit (P/N 902-649) to one output from the 4-way stopcock.
2. Connect a transducer approved for use with the bedside patient monitor to another output from the 4-way stopcock.
3. Ensure that the "off" tab on the 4-way stopcock is on the 4th, unused output. An uninterrupted fluid column should exist from the arterial catheter to the BP Transducer Kit transducer and bedside patient monitor transducer simultaneously.
4. Attach the bedside patient monitor transducer to the bedside patient monitor per the manufacturer's setup instructions.
5. Attach the BP Transducer Kit (P/N 902-649) transducer to the Argos monitor via the Transducer Interface Cable (P/N FG-015).
6. Make sure the BP Transducer Kit transducer (P/N 902-649) is level to the phlebostatic axis.
7. Zero the BP Transducer Kit transducer (P/N 902-649) to the Argos monitor using the procedure described below in §2.7.2, page 40. Then begin monitoring the patient.

2.5 Initial setup – Input patient data

Whenever the Argos monitor is powered on, or a new monitoring session is started (after a previous patient session is ended), the Add Patient Data screen is displayed:

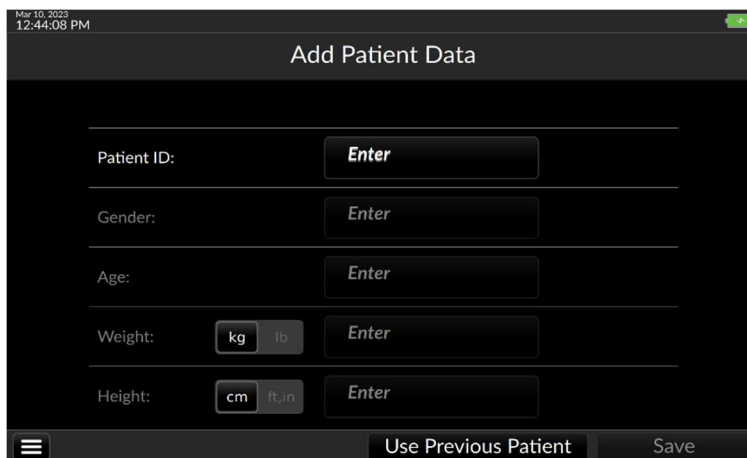



Fig. 2-18: Initial setup screen: Add Patient Data

Default unit system for patient demographic information is metric. To choose imperial units, use the unit toggle to adjust for lbs and ft/in before entering the patient's information.

- ▶ *Note that active or selected values in the Argos display as bold white text against a black background. Deselected values show as light gray text against a darker gray.*



WARNING
All fields must be completed accurately in order to ensure calculations of monitored values and indices are correct.



WARNING
Each patient must be given a unique ID. Patient IDs may be up to nine alphanumeric characters in length. Consult facility policy for distributing and tracking Patient IDs for instrument use.

When continuing to monitor the same patient as before:



WARNING
Never start monitoring from "Use previous patient" unless the user has verified the patient is the same patient as monitored immediately beforehand. Always carefully check that each value of the patient's demographic information is correct before proceeding with monitoring. If monitoring a new patient, use the menu to *End Session*.

The Add Patient Data screen permits quick entry of the previous patient's demographic information. To restart monitoring of the patient, tap Use Previous Patient:

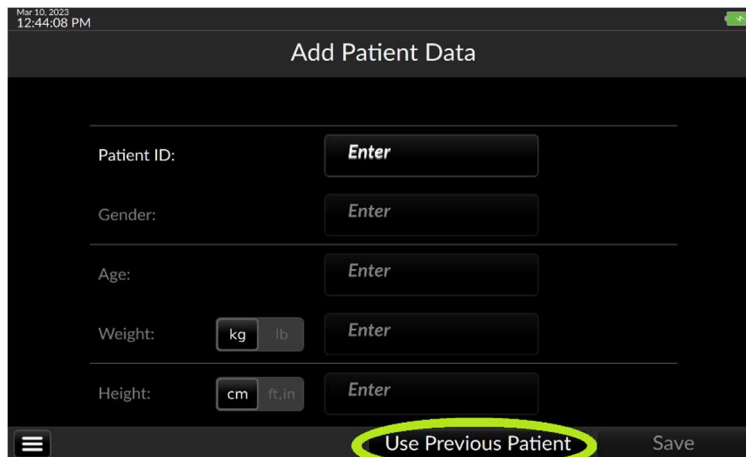

Fig. 2-19: Touch Use Previous Patient

The previous patient's demographic information appears, along with a user prompt.

- ▶ *Trends less than one day old will display when Use Previous Patient is selected. Otherwise, trend data is archived and is only available via export (see §2.11.4).*
- ▶ *The Argos monitor has a data capacity of 1200 hours.*

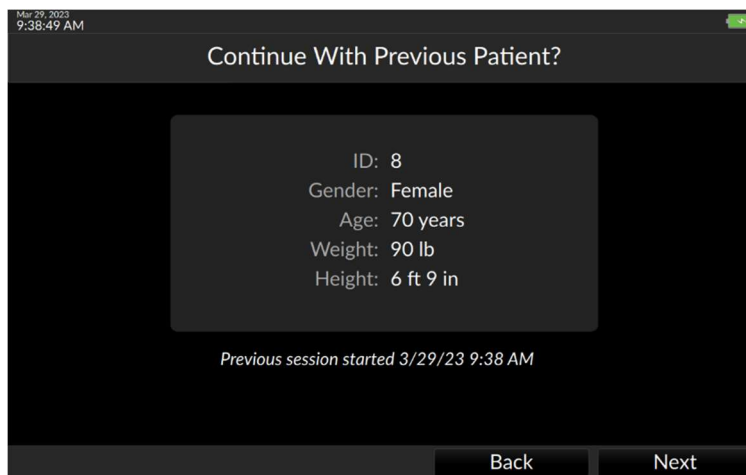

Fig. 2-20: Verify previous patient information is correct

Confirm demographic information is correct before proceeding.





WARNING

If the patient's demographic information as entered needs to be changed, it is necessary to start a new patient session.

Be sure the patient and demographic information match exactly before pressing *Next* to proceed with monitoring. Should any of the information fail to match, press *Back* to return to the Add Patient Data screen and enter the patient's demographic data.

When monitoring a new patient:

 **WARNING**
Once a user ends a monitoring session for a patient and another patient has been monitored, data for the first patient's session can only be exported via data export port, and can no longer be viewed on the Argos monitor.

 **WARNING**
Start a New Patient Session whenever a new patient is connected to the Argos monitor. Failure to do so may result in previous patient data in the historical displays.

To fill in a value, press the box marked *Enter*. A popup keyboard appears.

- ▶ *It is necessary to enter a Patient ID number for each patient before monitoring. The Patient ID number can be from 1-9 alphanumeric characters in length.*
- ▶ *The Patient ID's sole purpose is to tag and identify the patient internally in the Argos monitor's database.*

Use the keyboard to enter the value for the patient ID. Touching the Enter key  dismisses the keyboard.

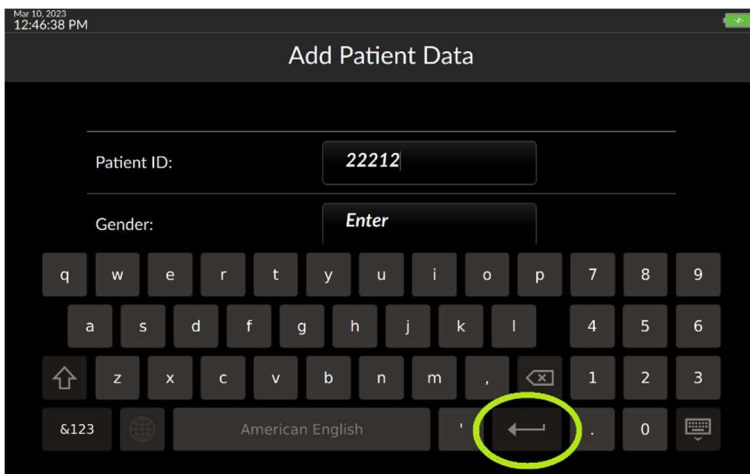

Fig. 2-21: Press OK to save and continue entering data

Touching the Gender entry field brings up a selection drop down.



Fig. 2-22: Select from the Gender drop down

Pressing any of the remaining demographic entry fields summons a virtual numeric keypad.

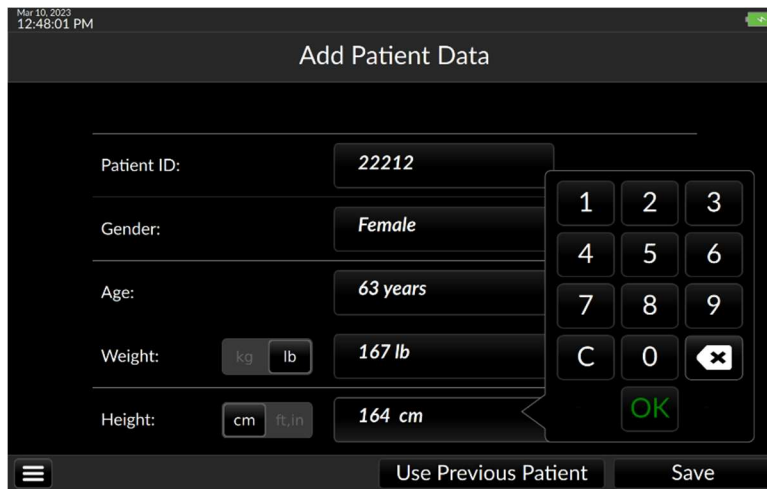

Fig. 2-23: Use the virtual keypad to enter numeric values

Complete patient age, weight, and height, then touch Save at the bottom right of the screen to save and proceed.



Fig. 2-24: Save entered data and proceed

Once patient demographic information has been saved, it cannot be changed. To change patient demographic information, the user must return to the Start New Patient screen.

2.6 Search *Patient Record* Database

Licensed devices configured to connect to a network patient record database (see §4.4.1.1) provide a Patient Record search function:

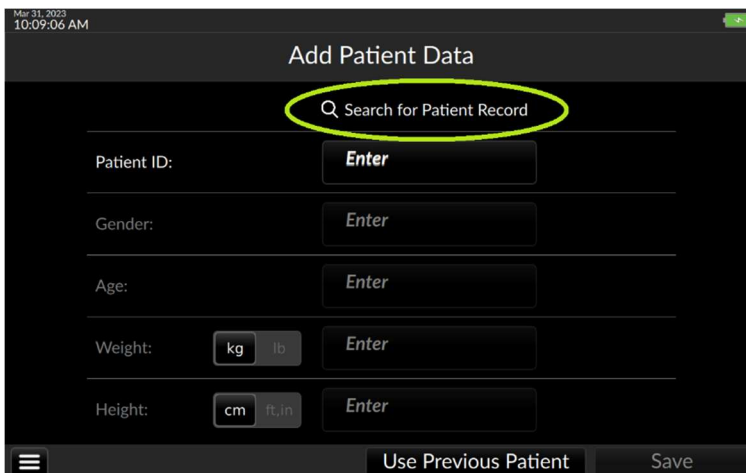

Fig. 2-25: Search for Patient Record (Corepoint)

Touch the magnifying glass icon to bring up a search box:

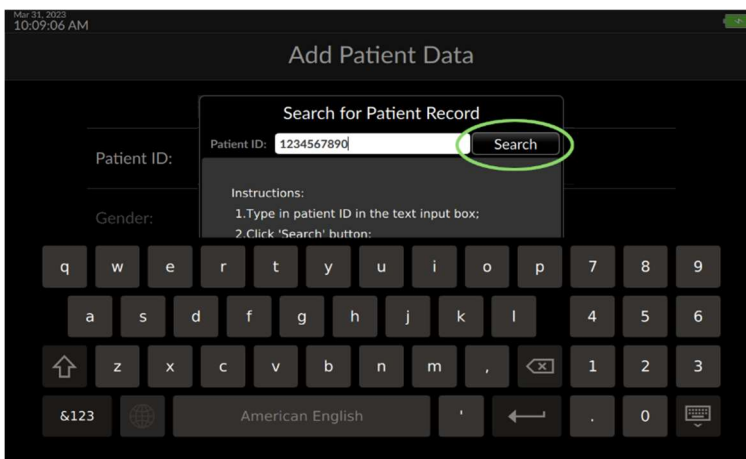

Fig. 2-26: Search for patient record continued

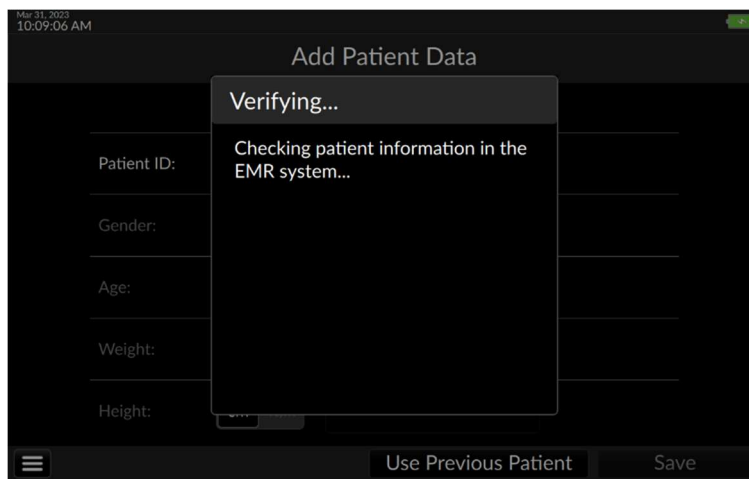

Fig. 2-27: Verifying patient record

More information can be found in §3.1.1, p. 87, **EMR Integration**.

2.7 Steps before monitoring

Once patient information has been entered, the Argos monitor is ready for use in conjunction with a bedside patient monitor; or if connected to a transducer, for zeroing the transducer prior to monitoring.

When the user has completed and saved patient demographic data entry, or have confirmed the previous patient information is correct, the Select Blood Pressure Signal Source screen appears.



WARNING

The Argos monitor presents visual alerts when parameter limits are exceeded, but does NOT provide audible alarms. Audible alarms are the function of the bedside patient monitor.

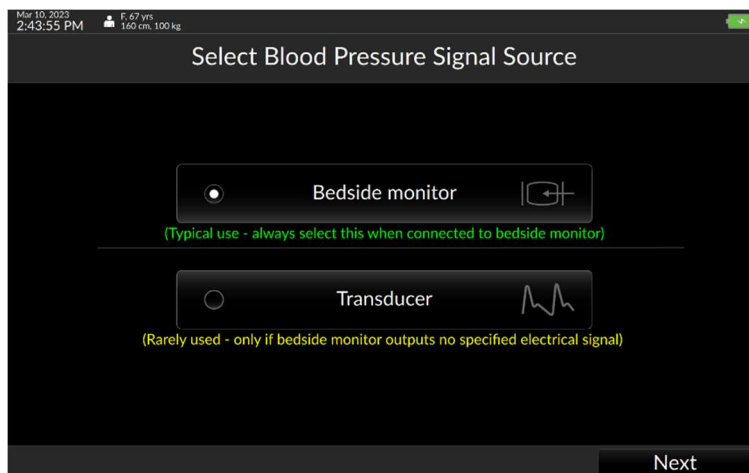

Fig. 2-28: Select BP Signal Source

Monitoring commences immediately and the Trend screen appears.

2.7.1 Connected to a bedside patient monitor

If the Argos monitor is connected directly to the bedside patient monitor, ensure *Bedside Monitor* is selected, then press *Next*.

2.7.2 Connected directly to a radial or femoral artery transducer

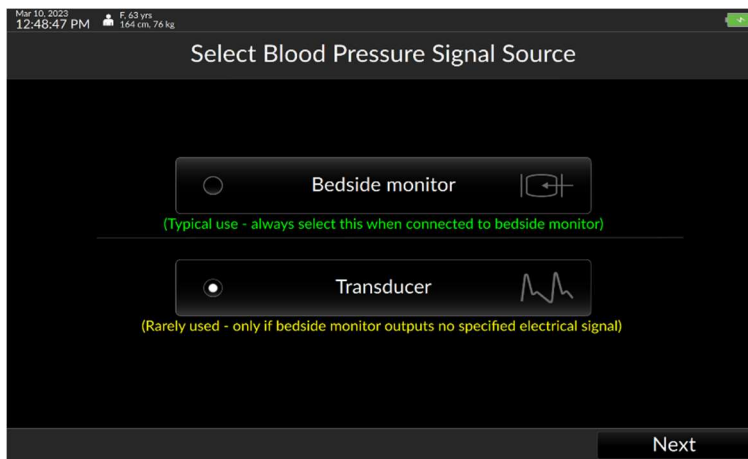

Fig. 2-29: Select *Transducer* and then press *Next*

Selecting *Transducer* will cause the Argos to read the invasive blood pressure signal from the transducer input on the side of the monitor. This connection can be to a radial artery or a femoral artery catheter.



WARNING

Failing to zero the transducer correctly may lead to incorrect monitoring results.



WARNING

The Argos monitor is intended only to supplement patient assessment, and must *only* be used in conjunction with a bedside patient monitor.



WARNING

If the Argos monitor is connected directly to a transducer, the transducer must also be connected simultaneously to a bedside patient monitor.

If the Argos is connected directly to the patient arterial line, it is necessary to zero the transducer immediately prior to monitoring. If *Transducer* has been selected as a BP source, pressing *Next* at the bottom of the screen initiates the Zero Transducer procedure.

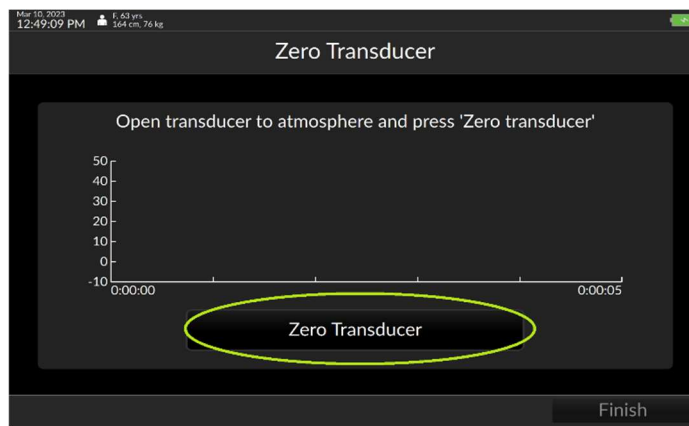

Fig. 2-30: The Zero transducer screen

Open the stopcock on the transducer line to the atmosphere. Then, press *Zero Transducer*.

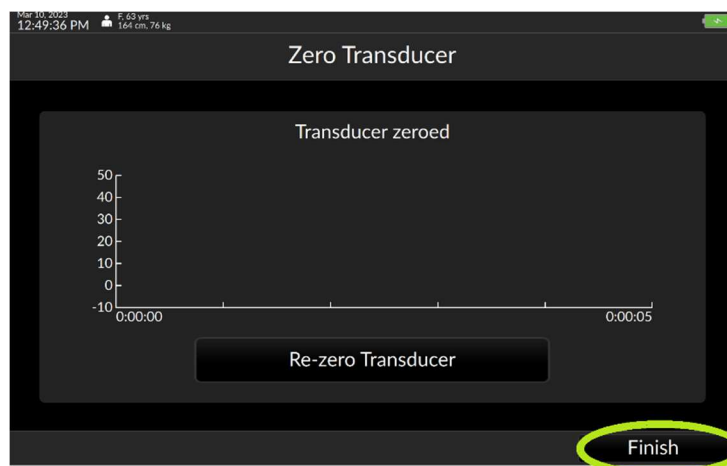

Fig. 2-31: Press finish to begin patient monitoring

Once the user has verified the pressure curve is flat, press *Finish*. The Argos begins monitoring.

Please verify the alert functionality whenever the device is turned on, immediately after beginning a new monitoring session. This procedure is described in Appendix 5.12, p. 118.

2.8 The Trend Screen

At startup, the Argos monitor displays the previous session's selected parameters.

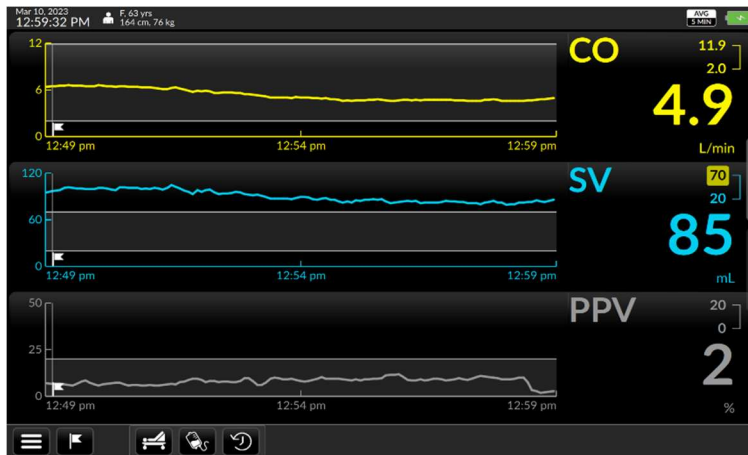

Fig. 2-32: The Trend screen

The Argos can display these parameters:

- Cardiac output (CO)
- Cardiac index (CI)
- Mean Arterial Pressure (MAP)
- Heart Rate (HR)
- Pulse pressure variation (PPV)
- Stroke volume (SV)
- Stroke volume index (SVI)
- Systemic vascular resistance (SVR)
- Systemic vascular resistance index (SVRI)
- Heart rate (HR)
- Blood pressure (BP)

2.8.1 The Parameter Settings Screen

To change displayed parameters, access the Parameter settings screen by pressing the parameter label. The Parameter settings overlay/tab allows the user to easily select a different parameter, change colors, adjust visual alert limits, and display additional information in the parameter label.

To select a different parameter:

Touch inside the label the user wishes to change to access the Parameter settings tab, then select the desired parameter from the dropdown.

If the user wants to change the CO trend to MAP (Mean Arterial Pressure): start by pressing the CO parameter label:

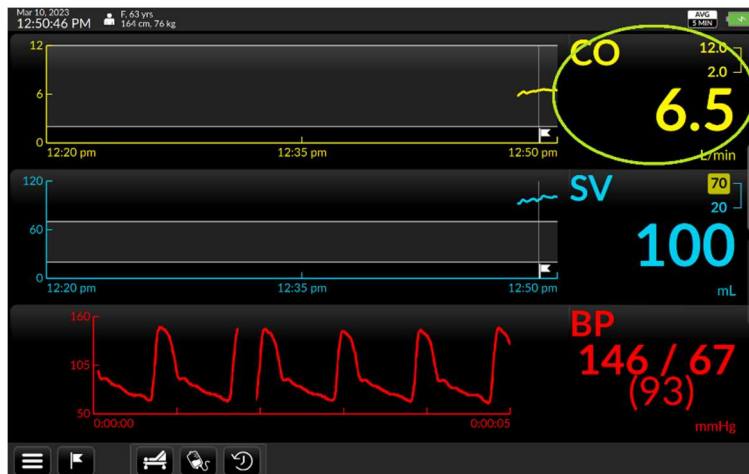

Fig. 2-33: Press any parameter label to change the displayed trend

The Parameter settings tab opens, with the currently-displayed parameter's initialism shown inside a selection box with a downward-facing triangle. Press it.



Fig. 2-34: Tap the current trend name inside the box to change it

A drop down list appears. Scroll up or down to view the complete list.

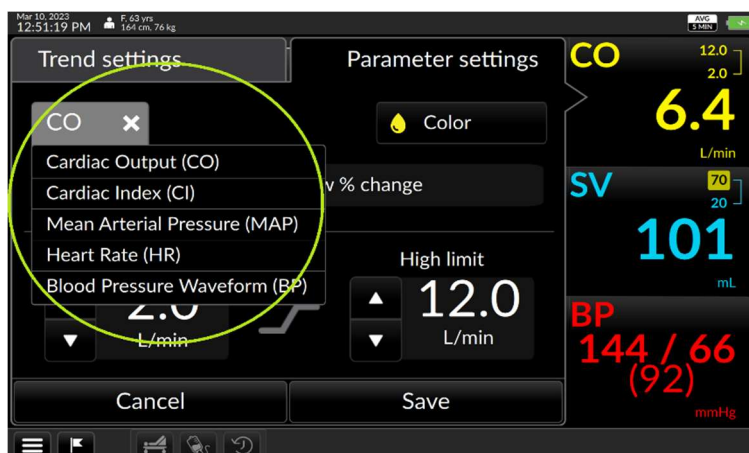

Fig. 2-35: The drop down list of trends

Tap on the name of a trend to select it. The selection box closes.

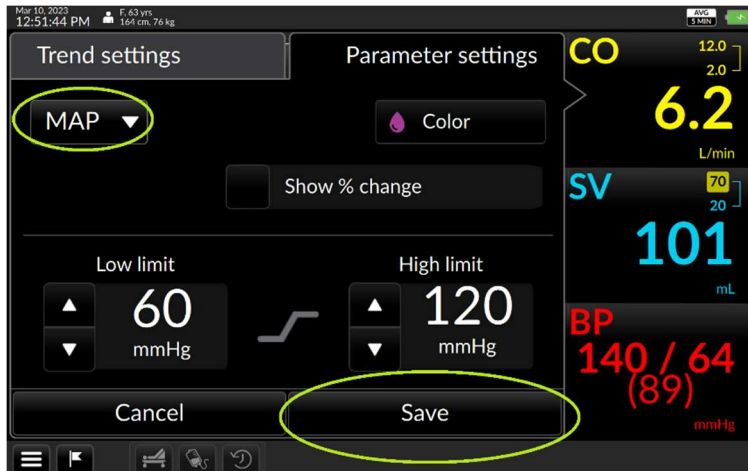

Fig. 2-36: MAP selected. Press Save to continue

Press the Save to save the selection and return to the main Trend screen. The selected parameter is now displayed.



Fig. 2-37: MAP displayed

- ▶ *The Argos retains the selection of parameters between sessions. If the user desires to return to the default selection of monitored parameters, navigate to User Menu/Device Settings, then tap the box labeled Reset to default configuration. Factory default settings will be reloaded.*
- ▶ *Should the user select a parameter that is already being displayed in a different trend window, the currently-selected parameter will display the one the user selected, but the previous parameter will display in the other trend window.*
- ▶ *The Parameter Settings page may also be used to show additional monitoring information in the label.*

2.8.2 Display change since event

The User can show the net change in any parameter since an event – including monitoring initialization, or from an event that has been marked. For example, while monitoring a patient's cardiac output (CO) if the user wishes to track the net change in CO over a period of time then call up the Parameter Settings window by tapping the Parameter Label:

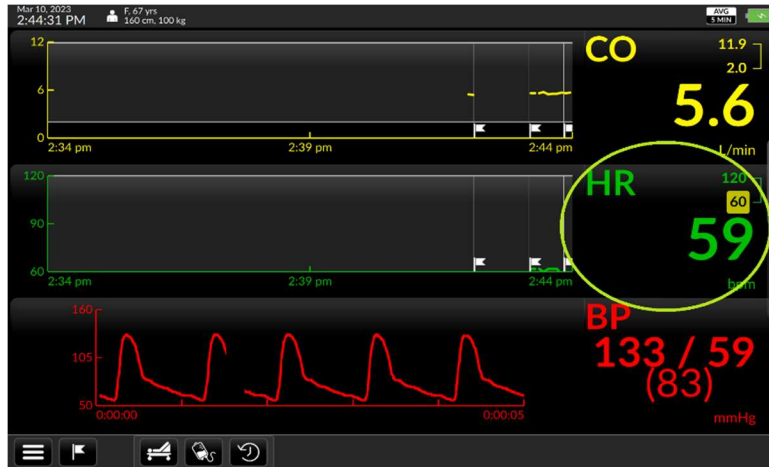

Fig. 2-38: Touch the label to access Parameter settings

The Parameter Settings page opens. Show % change is located near the center of the screen.

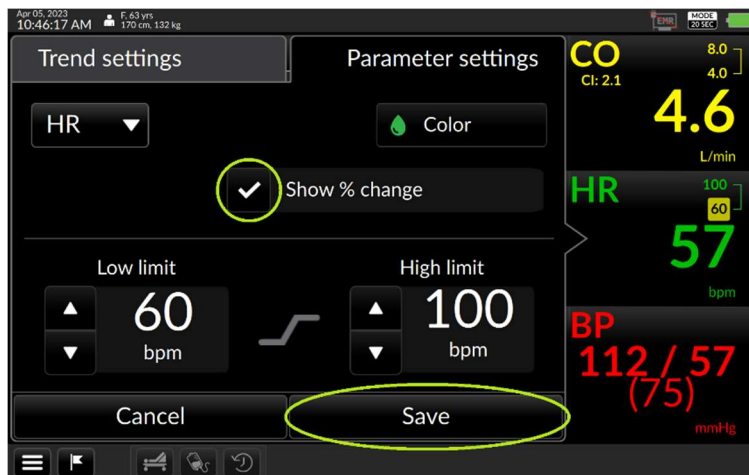

Fig. 2-39: "Show % change" shown highlighted

Tap the checkbox. Press Save to save and return to the monitoring screen. The percentage value of the change since the previous event flag is now displayed.

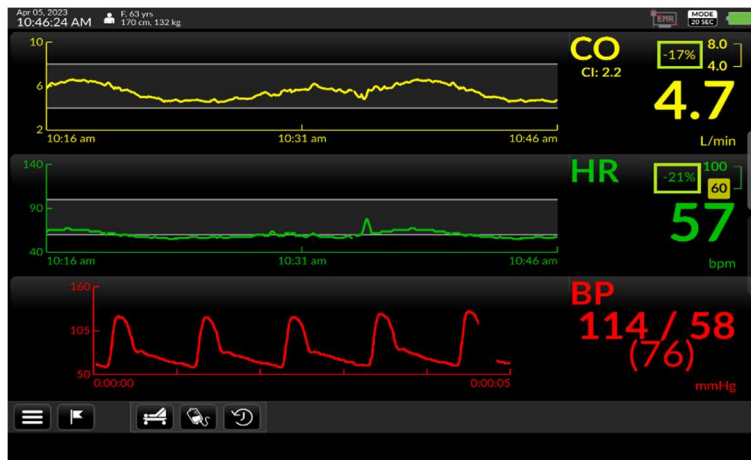

Fig. 2-40: Percentage change is measured from the flagged event

- ▶ When monitoring the response of the patient to an intervention, the user should take note of the selected monitor mode of operations, displayed in the Status Bar at the top right-hand portion of the screen. In the case of the 20 second mode option, rapid changes in the patient's hemodynamics will be reflected more rapidly in the updated parameter display, whereas with the 5-minute monitoring mode, hemodynamic changes will be reflected over a longer period of time. To change the monitoring mode, select the Device Settings option from the User Menu. Refer to §2.11.6.4, p. 67 for more information.
- ▶ Performing a Dynamic Assessment will replace the percent change figure to reflect the change from baseline of the Dynamic Assessment. A new flag representing this time point of the end of the baseline will be automatically inserted and the percent change will reflect the change from this time.
- ▶ At the end of the Dynamic Assessment procedure when the result is calculated, a new flag is inserted automatically indicating the end of the assessment. Any percent changes visible after the end of the Dynamic Assessment are calculated with respect to the time point indicated by the result flag.

2.8.3 Display an associated index or value

Certain parameters can be displayed with an associated indexed value that is normalized to the patient's body surface area

Trend displayed	Optional numerical trend value to show
Cardiac Output (CO)	Cardiac Index (CI)
Stroke Volume (SV)	Stroke Volume Index (SVI)

If the user wishes to display the patient's Cardiac Index. Access the Parameter Settings page by touching the parameter label on the main screen. The *Show CI* selector is found on the left-hand side of the screen.

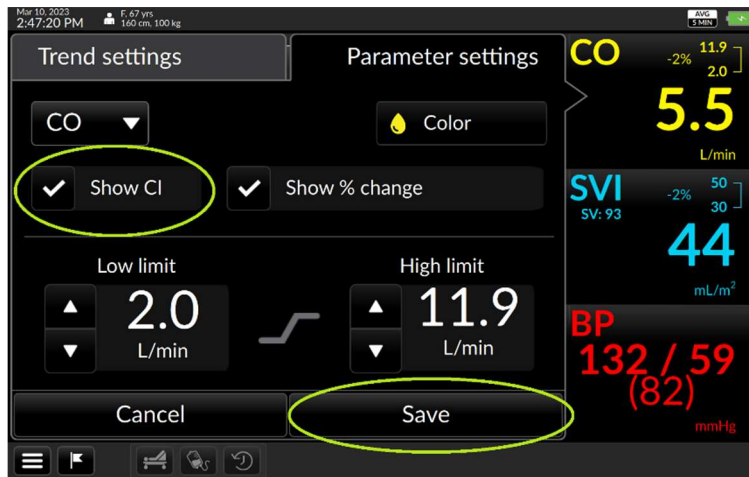

Fig. 2-41: "Show CI" selection box highlighted

Tick the box to display CI. Press Save. To return to the Trends screen, showing the CI value in the label.

2.8.4 Changing colors and graph limits

From the Parameter Settings page, the user can also change the color of a trend and text and change the maximum and minimum limits of the parameter graph value (Y-axis). To change trend display color: Touch inside the parameter label field to call up the Parameter Settings overlay. The color selector is marked by a droplet icon bearing the currently-displayed color:

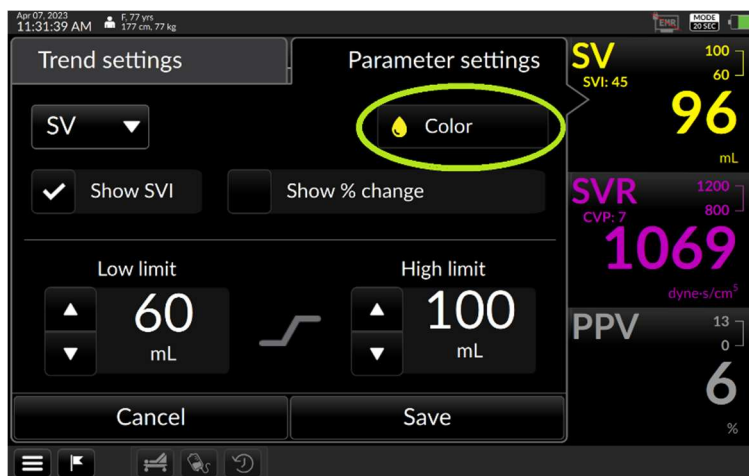

Fig. 2-42: The Color selector

Touching the color selector brings up a palette of colors:

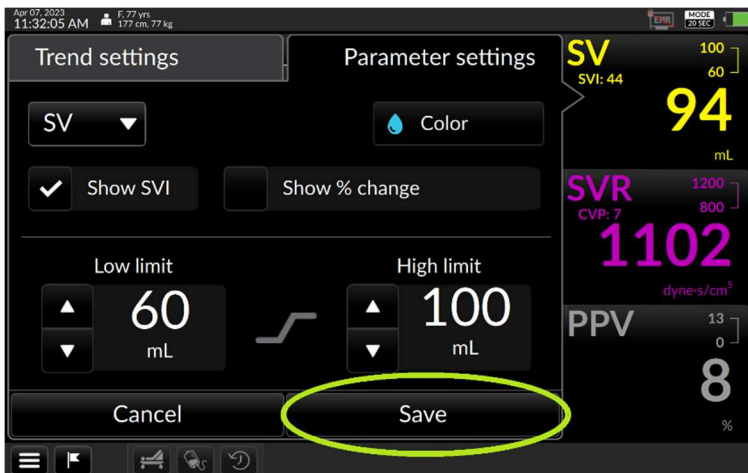

Fig. 2-43: Color selection

Choose a preferred color. Press Save to save the value and return to the trend screen. The parameter shows in the chosen color.

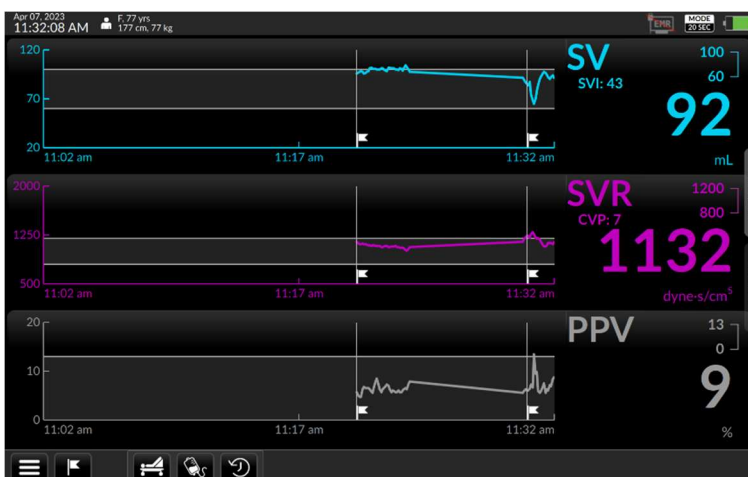

Fig. 2-44: SV trend and label displayed in blue

2.8.5 To change alert limits

Bring up the Parameter Settings overlay by pressing the parameter label field. Both low limits and high limits are shown.

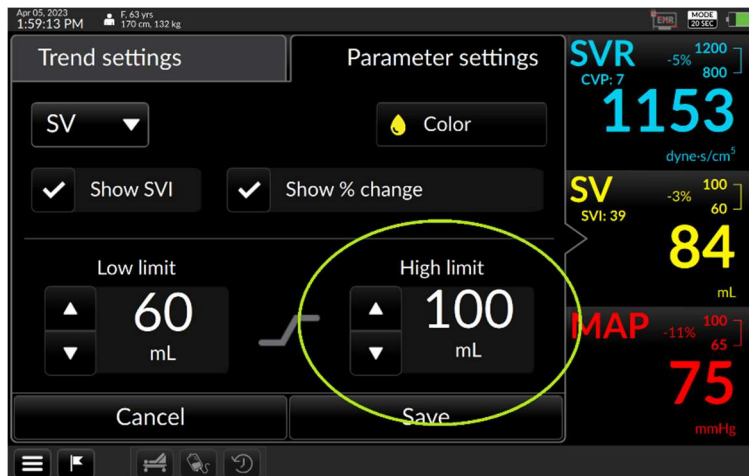

Fig. 2-45: High limit adjuster in Parameter settings

Adjust the value by tapping the up arrow or down arrow until the desired limit is reached. Adjust the values to the desired setting and press Save to return to the main monitoring screen.



Fig. 2-46: CO upper alert limit reached

2.8.6 Moving chronologically through trends

The User can rapidly examine trend history by swiping a trend to the right (moving to an earlier timeframe) or to the left (to a later time).

Note that only the trends recorded from the last monitored patient may be reviewed on the monitor, provided they have been recorded entirely within the previous 24 hours.

- *The Argos monitor can store up to 1200 patient hours of data in its memory. To access prior patients' data, use the Data Export function with a USB drive (§2.11.4).*

Placing a fingertip on a trend brings up a light gray triangle at the left hand side:



Fig. 2-47: A fingertip touching the MAP trend brings up a gray triangle

Note the gray arrow appearing on the trend coordinate line when holding and scrolling to see past trend data:



Fig. 2-48: Closer view of trend and label

When the trend has been shifted to an earlier timeframe, another gray arrow appears on the right side while the timeframe is being moved.

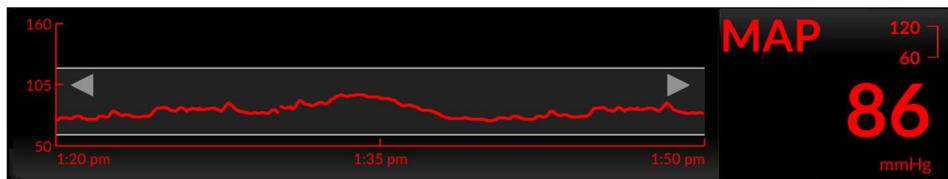

Fig. 2-49: Arrows at both ends of the trend indicate an earlier view

To return to real-time, swipe left as far as the trend will go.

Trend Settings

Scaling trends

The size of the time period shown – the scale of the X-axis – can be adjusted to any value between 10 minutes and 12 hours; by default the time scale is 10 minutes.

Fingertip control allows rapid rescaling. To compress the trends – to show a *larger* time interval – place the tips of a thumb and forefinger, or two fingers, horizontally on a trend, and draw them together in a pinching motion.

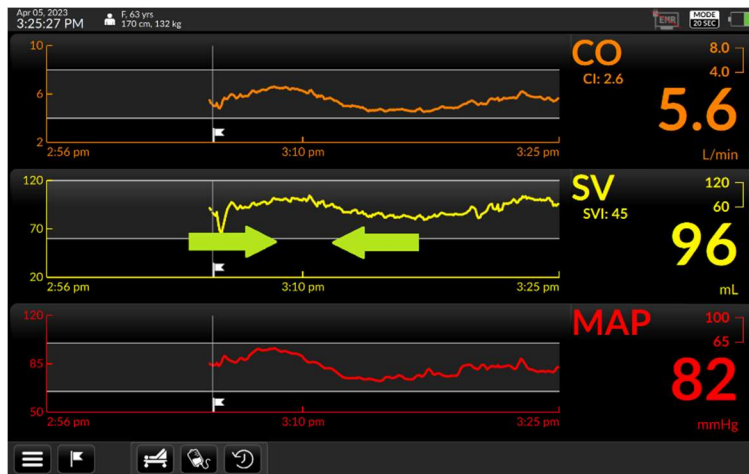

Fig. 2-50: Draw two fingertips together to compress the time scale

The trend's time axis will take in a greater duration.



Fig. 2-51: All three trends are lengthened to approximately one hour

To expand the time scale – to show a *smaller* interval in the trend windows – spread two fingertips apart.

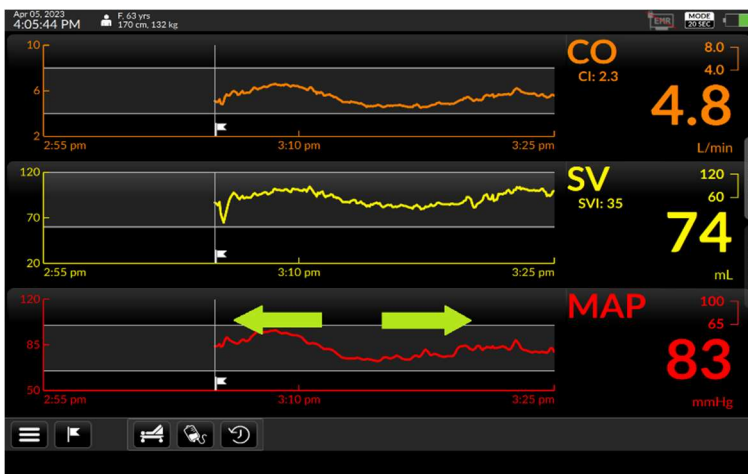

Fig. 2-52: Time scale is 30 minutes before manual adjustment

The time scale has now gotten smaller, in this case to ten minutes, the smallest available viewable time scale.

Trend settings: Scaling trends

The User may change the time scale from the default 10 minutes to a preset numeric unit of time from the Trend settings page as well. By default, trends display over 10 minute intervals.

Tap a trend with a fingertip.

The Trend settings page opens. Current Time Scale interval is displayed in a selector box.

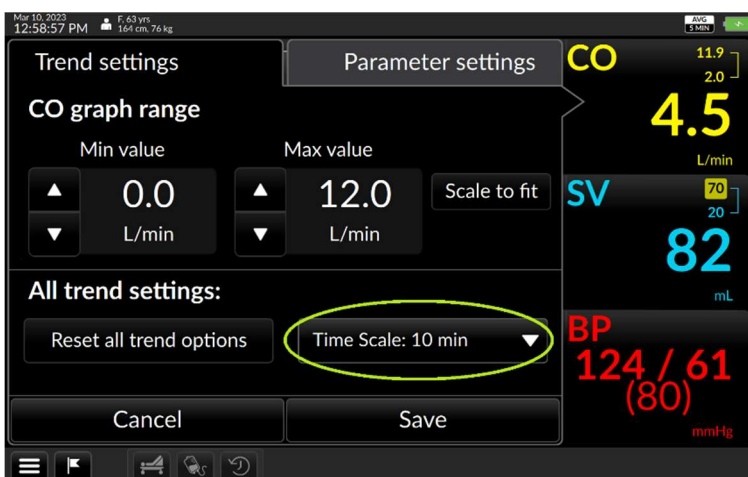

Fig. 2-53: Time scale is shown on Trend settings

Tap the box. A drop down menu lists a choice of possible intervals:

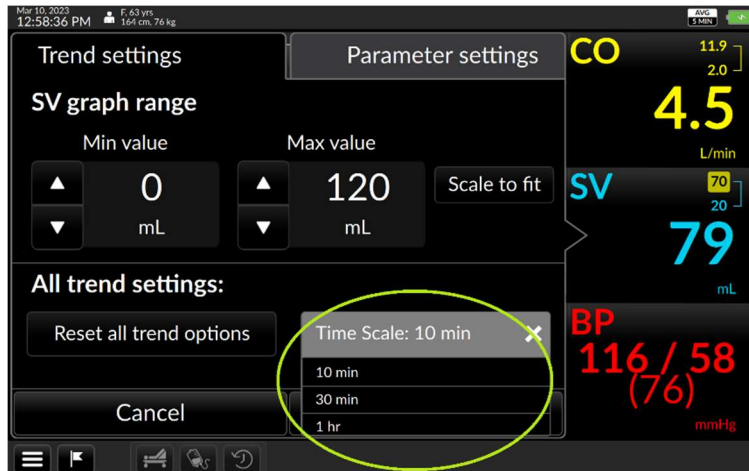

Fig. 2-54: Time scale intervals range from 10 minutes to 12 hours

The Time Scale selection box is set to 10 minutes by default. Touch it to adjust it. Possible values are 10 minutes, 30 minutes, 1 hour, 2 hours, 3 hours, 6 hours, and 12 hours. Select the interval the user prefers, then press Save. The Trend screen returns with the selected scale.

2.9.3 Changing the graph range (y-axis)

Maximum and minimum values of the coordinates for each trend parameter may be raised or lowered from the Trend settings screen. You can also choose to allow the trend to determine the scale values.

To reduce the maximum range value for Mean Arterial Pressure (MAP), press the trend whose y-axis range the user wishes to alter on the Trend screen to bring up Trend settings.

Note the *graph range* portion of the screen, showing Min(imum) and Max(imum) values:

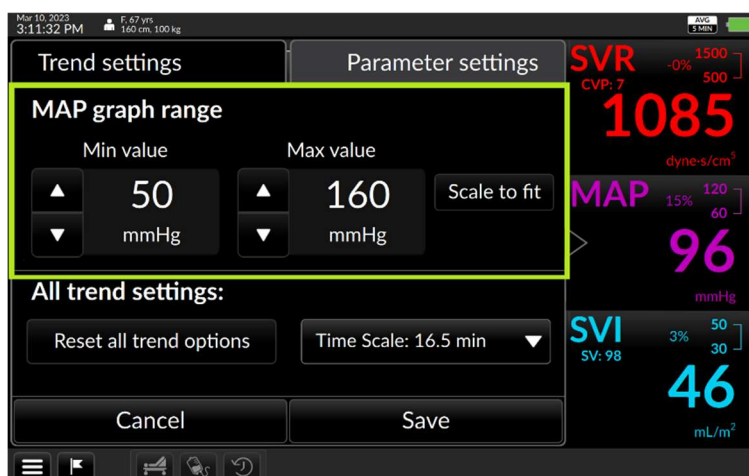

Fig. 2-55: Set MAP graph range values here

Press the down arrow to lower the maximum MAP graph value.

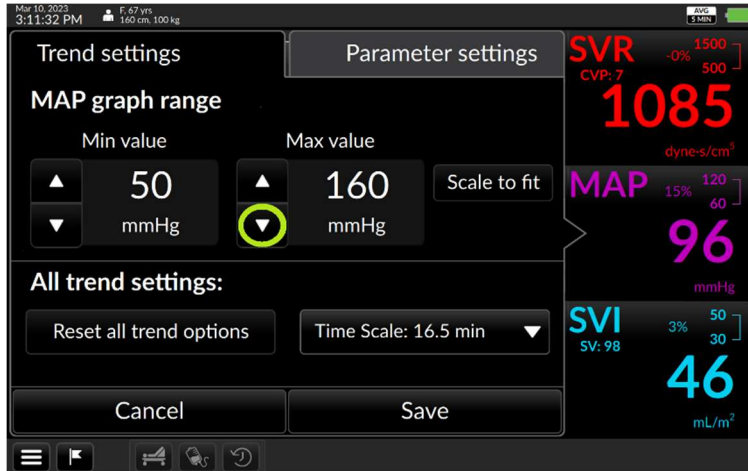

Fig. 2-56: MAP trend settings with max graph value selector highlighted

Use the triangle to incrementally decrease the numerical value.

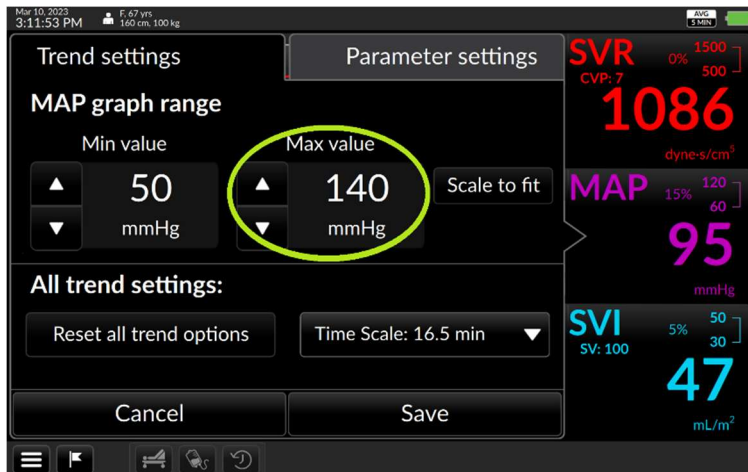

Fig. 2-57: Max graph range value is now 140 mL

Press Save to return to the Trend screen with the new value.

- ▶ Choosing Scale to Fit allows the trend to set minimum and maximum graph coordinates.
- ▶ To return all Trend settings to default values for a displayed Trend, press the Reset all trend options box. Settings will revert to default values.

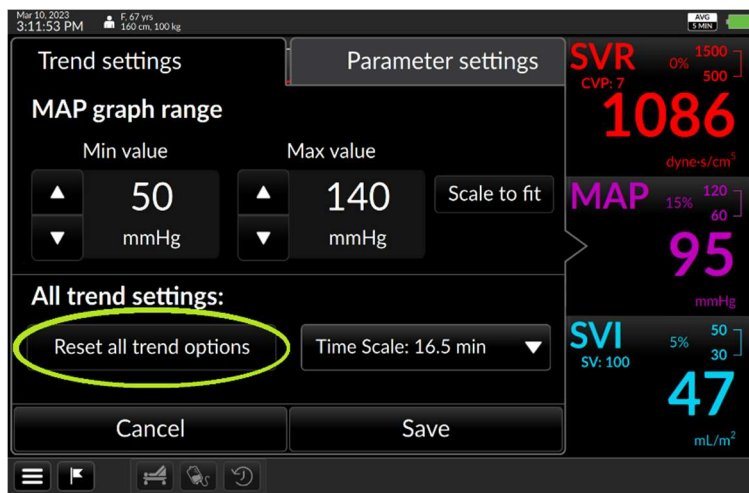

Fig. 2-58: Press Reset all trend options to return settings to defaults

2.10 The Tabular View

Tabular view presents a table of earlier discrete hemodynamic values, at a user-specified interval, during the current continuously-monitored patient session. The user may select increments of 15 minutes (the default), 30 minutes, 1 hour, or 2 hours.

Current real-time values display in green on the left side of the Tabular View screen.

Time	Mar 13, Mon 9:24 AM	Mar 11, Sat 5:30 PM	Mar 11, Sat 5:45 PM	Mar 11, Sat 6:00 PM	Mar 11, Sat 6:15 PM	Mar 11, Sat 6:30 PM	Mar 11, Sat 6:45 PM
CO L/min	5.6	4.7	6.4	5.3	5.0	4.6	6.5
CI L/min/m ²	2.6	2.2	3.0	2.5	2.3	2.2	3.0
SV mL	96	86	98	94	85	83	100
SVI mL/m ²	45	40	46	44	40	39	47
SVR dyne-s/cm ⁵	1090	1122	1077	1074	1195	1151	1086
SVRI dyne-s/m ² /cm ⁵	2325	2394	2297	2290	2549	2455	2316
PPV %	2	10	7	5	3	9	7

Fig. 2-59: Tabular View

The Control Bar (see §2.11, p. 58) is displayed along the bottom of the Tabular View screen and the Status Bar is displayed at the top.

Tabular view options

To change the time interval, tap the desired value.

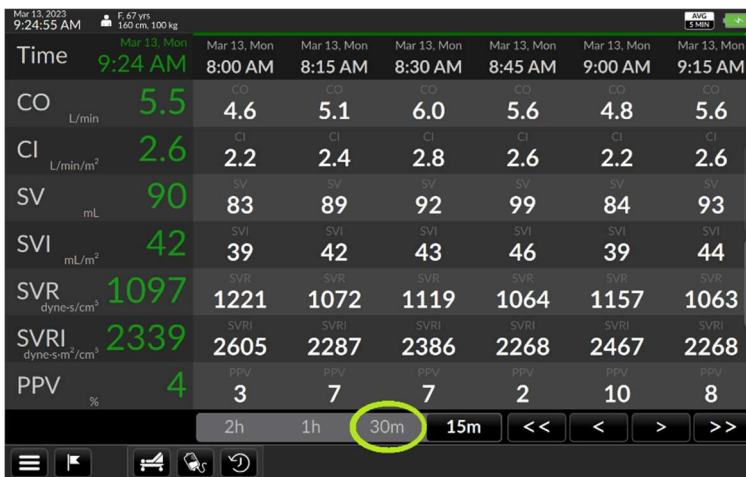

Fig. 2-60: Tap the desired interval

The increment changes to the selection.

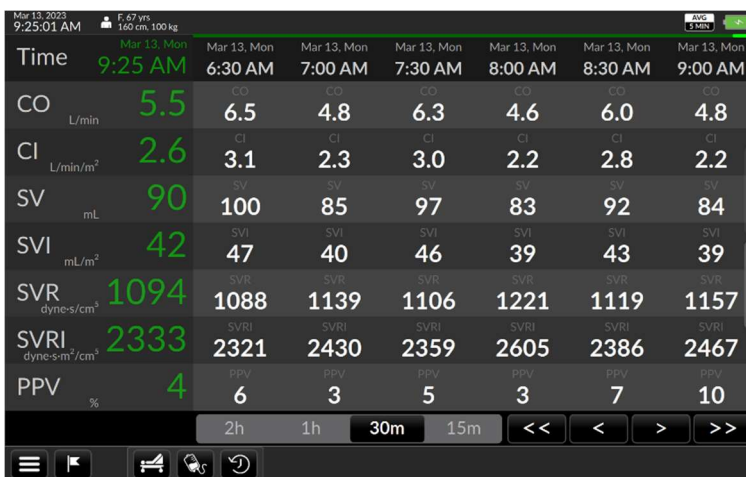

Fig. 2-61: Data is now shown in 30-minute intervals

Time windows can be rapidly advanced or reversed using the << or >> icons:

- << Quickly moves Tabular View display to the start of the monitoring session
- < Moves Tabular View display to previous increment of the selected time period
- > Moves tabular view display to next increment of the selected time period
- >> Quickly moves tabular view display to the most recently recorded values

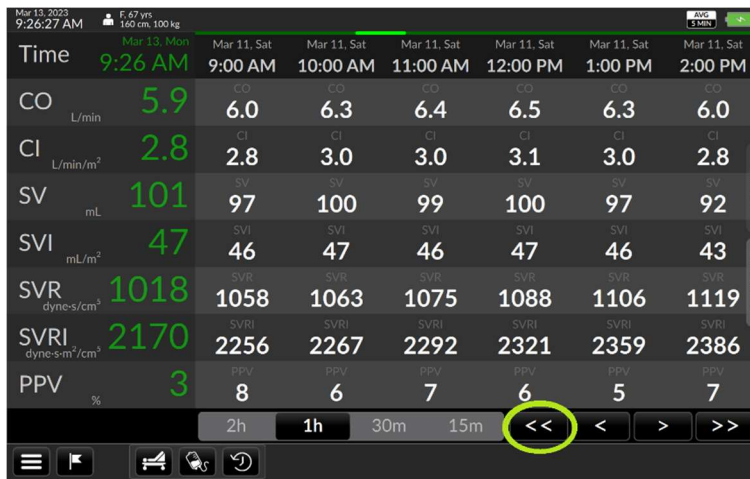

Fig. 2-62: Touch the double arrow to rewind or fast-forward data

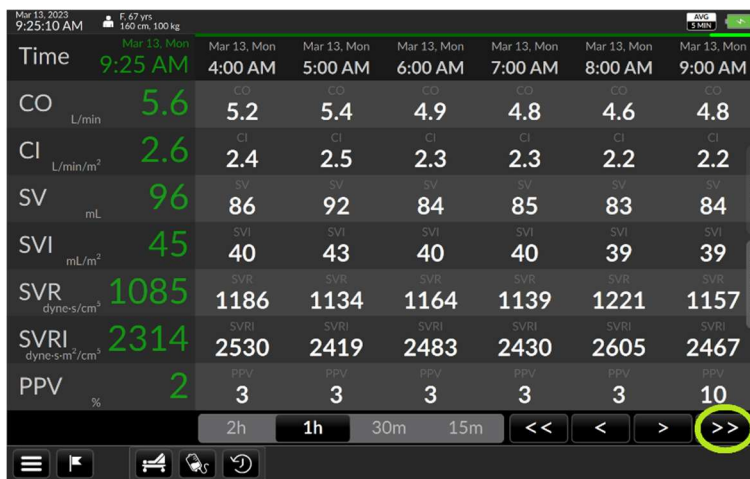

Fig. 2-63: Data rewind to start of monitoring session

Trend scrubbing in Tabular View

Drag a fingertip leftward on the Tabular View to scroll forward in time increments.

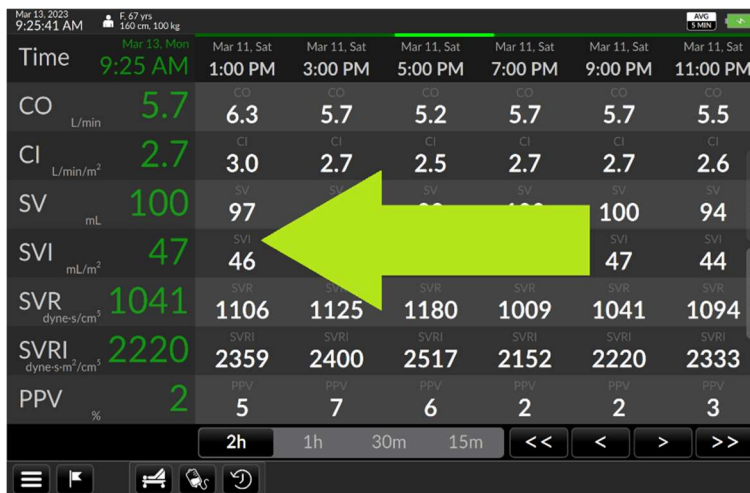

Fig. 2-64: Drag leftwards for later values

Drag a fingertip rightward on the Tabular View to scroll backward in time increments.

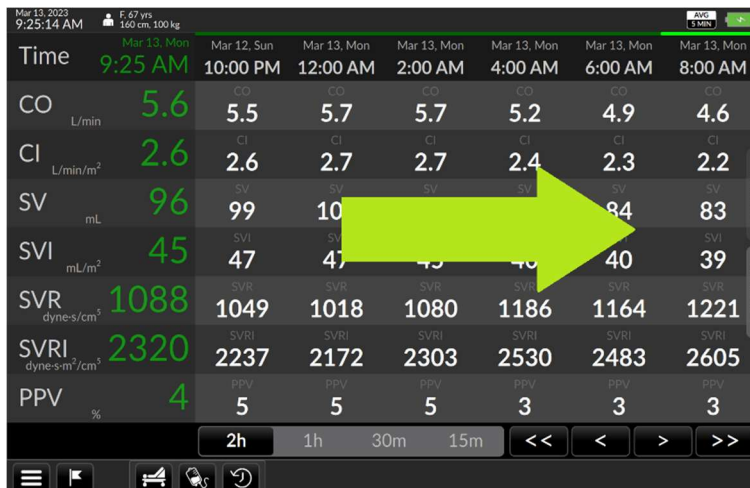

Fig. 2-65: Drag rightwards for earlier values

2.11 The Control Bar & Status Bar

The Control Bar at the bottom of the screen displays

- User menu access indicator
- Events access indicator
- Dynamic Assessment Functionality
 - Passive Leg Raise (PLR)
 - Fluid Bolus
 - Dynamic Assessment History

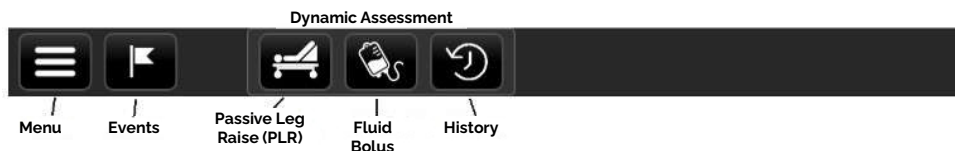

Fig. 2-66: Control Bar elements

The Status Bar at the top of the screen displays Patient Demographics

- Date and Time
- Power/ Battery Status
- EMR/ Network Status (if EMR enabled)
- Monitoring modes (20 seconds or 5 minutes)



Fig. 2-67: Status Bar elements

Indicators and menus provide access to critical functions, allowing the user to:

- Switch to a new patient
- Re-zero the transducer
- Access device settings
- Export monitoring logs
- Shut down
- Obtain information about the device
- Install software updates and software license
- Mark / recall events
- View system settings
- View networking and EMR status (*if EMR enabled*)
- View monitoring mode







2.11.1 Battery State Indicator

At the top far right of the Status Bar, the battery indicator displays the power level and A/C outlet connection status.

	<p>CAUTION</p> <p>The Argos Cardiac Output Monitor is intended for operation while plugged into an AC wall outlet. Although it will continue to function at full capacity on battery power alone, such as when an emergency power outage occurs, it is not designed for cordless use. In case of a power outage, use of the Argos Cardiac Output Monitor will last until the battery is expended.</p>
---	--

Should the monitor become disconnected from AC outlet, it will continue to operate for approximately 30 minutes.

Table 4: Battery icons

Battery State	Icon
When the battery is properly connected to an operational external power source, the indicator icon is colored green and shows a lightning bolt	
When the battery is disconnected from external power, the icon is green, but without the lightning bolt	
As the battery loses power, the green shade lowers	
When battery power drops below 25%, the battery icon shows yellow	
Immediately prior to emergency shutdown, the battery shows a sliver of red	
If the monitor is plugged in while the battery is depleted, the bolt becomes visible as the battery charges	



WARNING

Do not unplug the device when the battery is depleted.

- ▶ *The Monitor will automatically shut down if on battery power and the battery has less than 10% charge remaining.*
- ▶ *If the monitor abruptly shuts down immediately after booting, it is because the power supply is not attached and the battery is insufficiently charged. Plug the monitor in to continue use.*

2.11.2 The User Menu

The User Menu enables the user to

- End a session and begin monitoring a new patient
- Power down
- Save patient monitoring data
- Change system settings for the Argos, including monitoring mode of operations, date and time formats, units, and language
- Export monitoring data via USB
- Restore all settings to factory default values

To access the User Menu, press the User Menu navigation icon beside the Events icon at the lower left hand side of the Control Bar:

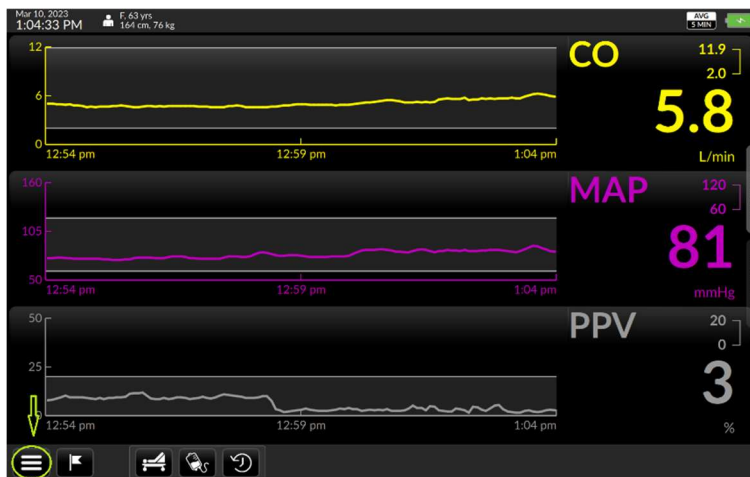

Fig. 2-68: Touch the three-lined User Menu navigation icon to access it

The User Menu appears in the bottom left-hand corner.

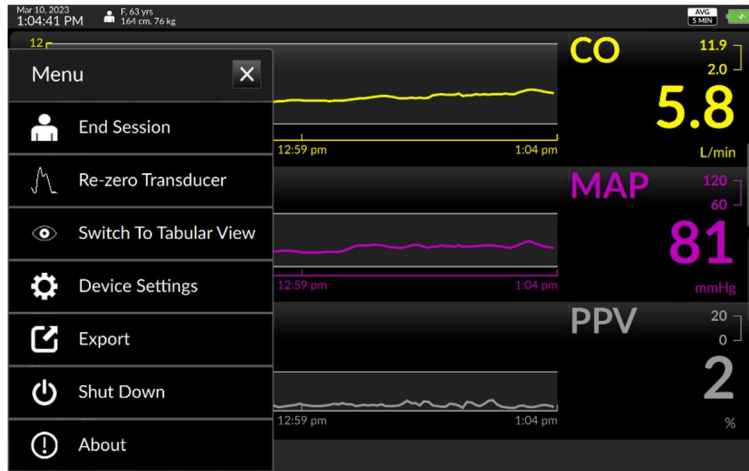

Fig. 2-69: The User Menu

2.11.3 End Session

Select End Session from the User Menu. This will bring up a confirmation screen.

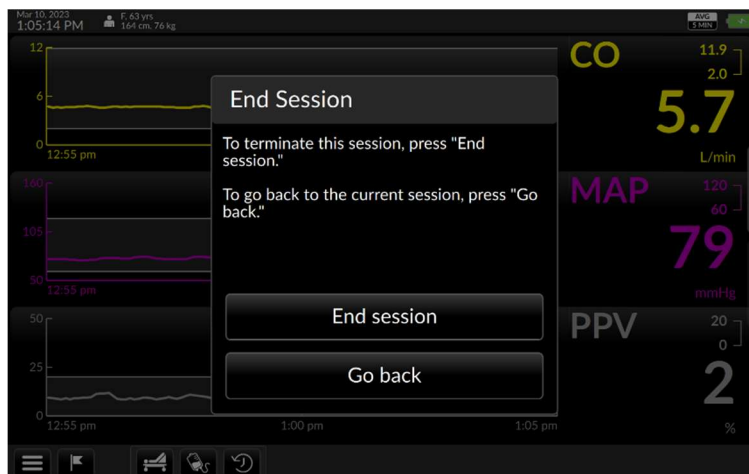

Fig. 2-70: End Session confirmation screen

To end the current session press End Session as directed by the screen. This will allow the monitor to begin a new monitoring session with a new patient.



WARNING

Never start monitoring from "Use previous patient" unless the user has verified that the patient is the same patient as monitored immediately beforehand. Always carefully check that each value of the patient's demographic information is correct before proceeding with monitoring. If monitoring a new patient, use the User menu to call up the End Session to end the session for the current patient, then a new patient screen will be presented.

The Add Patient Data screen will appear. Follow the instructions for the Add Patient Data screen (§2.5, page 34).

If the user wishes to continue with the patient being monitored, press *Continue with current patient*, as directed.

2.11.3.1 Re-Zero Transducer

If the Argos is connected directly to a transducer and the user needs to re-zero the transducer, select *Re-Zero Transducer* and the Zero transducer screen will appear.

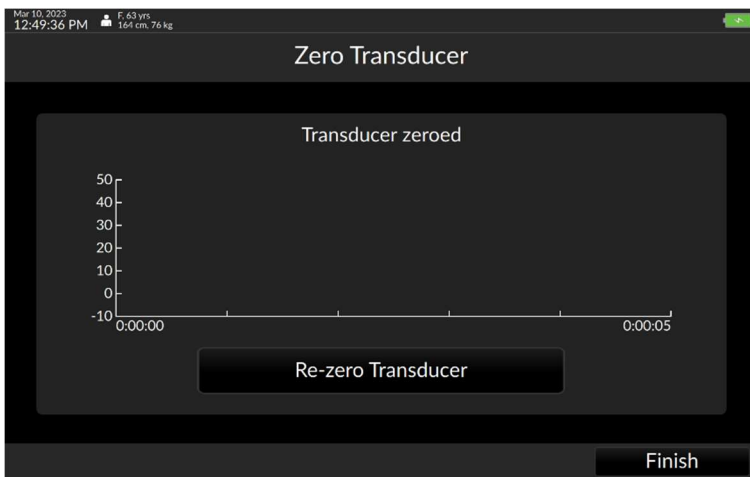

Fig. 2-71: Re-zero transducer screen

2.11.4 Export

Patient monitoring data can be exported to a USB drive via the Export Data menu. Plug a USB drive into one of the Argos's USB ports. Then from the User Menu, select Export to bring up a list of saved monitoring sessions.

Sessions are listed chronologically, identified by Patient ID number. The user identifies the patient and session they wish to export, tap it to select it, insert a formatted USB drive into one of the Argos's data export ports, and press *Export*.

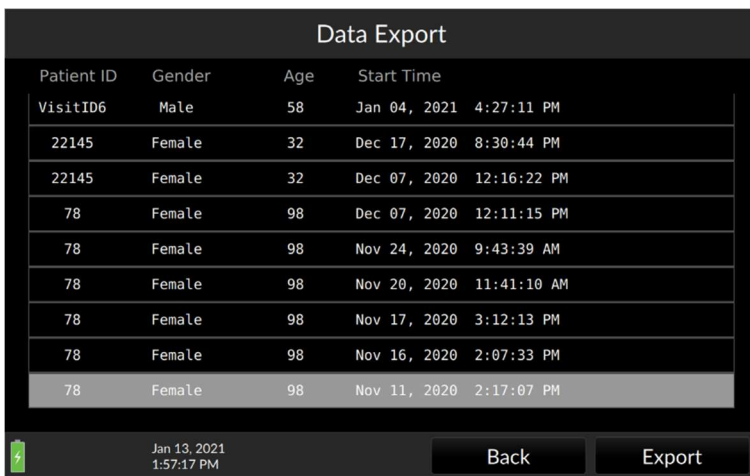

Fig. 2-72: Tap the Export box

During the *export* process a *Please wait* message pops up. If a USB drive is not inserted, an error message appears: Insert a USB drive as directed, and press OK to continue. Once the Export data screen returns, data has been successfully exported, and the USB drive may safely be removed. Press *Back* to return to the Trend screen.

Shut Down



WARNING

Only power off the Argos Monitor using the Shut Down function from the User Menu.
Never power off the monitor by pressing the power switch or unplugging the device.

Upon device shutdown patient data is retained for export via the data export port. (For directions on exporting data, see §2.11.4, page 62.)

Pressing *Shut Down* brings up a confirmation prompt.

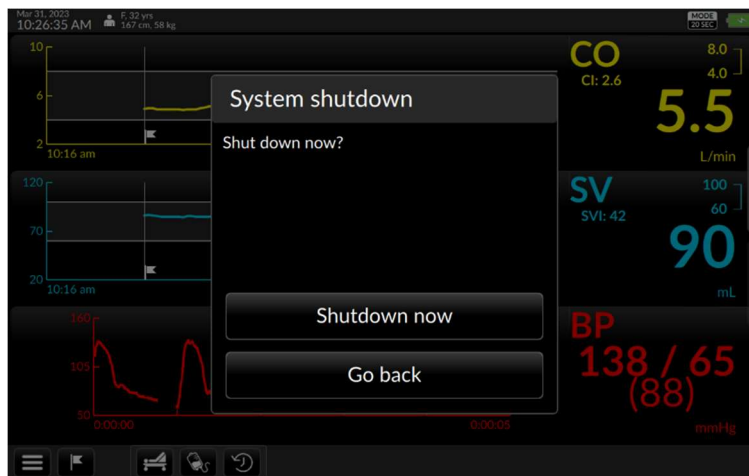

Fig. 2-73: Confirm shutdown

Press *Go Back* to resume monitoring, or *Shutdown* to end the session and turn the Argos off.

2.11.6 About

Select *About* to view firmware and software version information. Licensed versions show the days remaining until license expiration and licensee information.



Fig. 2-74: About screen (Licensed versions)

The About page will indicate if any of the EMR licenses have expired.



Fig. 2-75: EMR software licenses have expired

2.11.6.1 Device Settings

Selecting *Device Settings* Brings up the Settings menu.

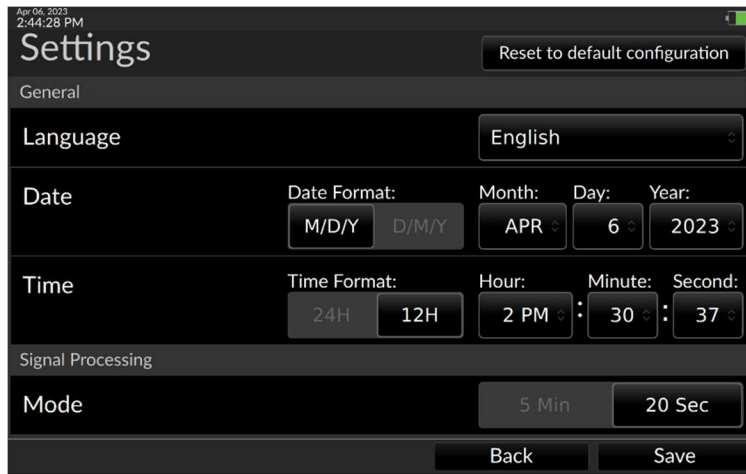

Fig. 2-76: The Settings menu, top

Touch and drag the screen or pull down the scroll bar on the right edge to bring the bottom of the Settings menu into view

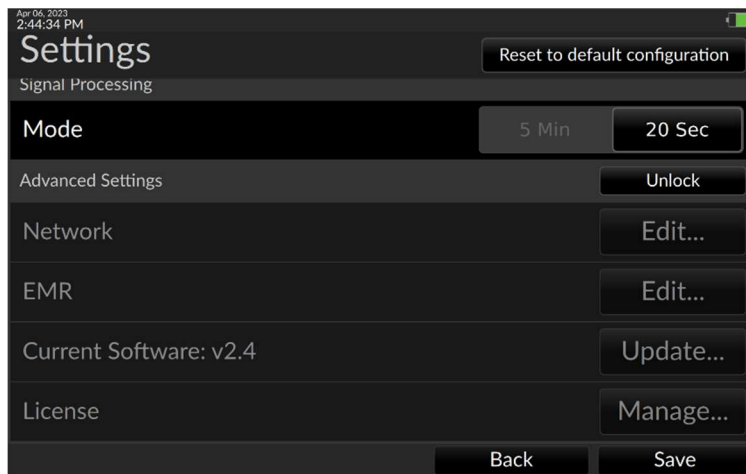

Fig. 2-77: The Settings menu, bottom

- ▶ *Date and Time, and Advanced settings cannot be changed during a patient monitoring session.*

Reset to default configuration

To return all device settings to factory defaults, press *Reset to default configuration*:

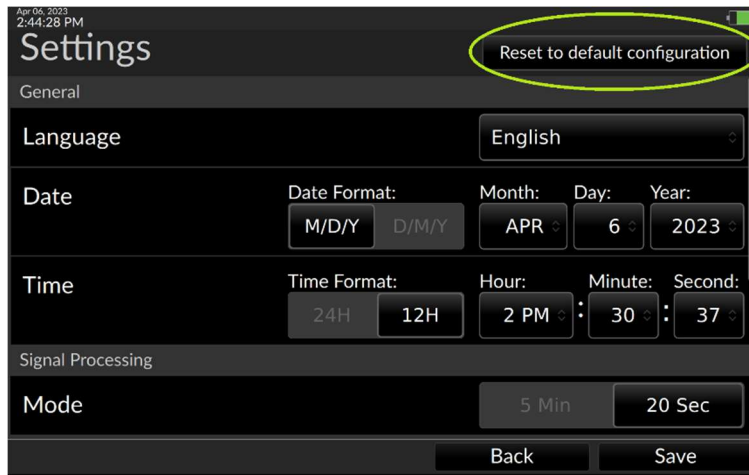

Fig. 2-78: Reset to default configuration selector

A confirmation screen appears:

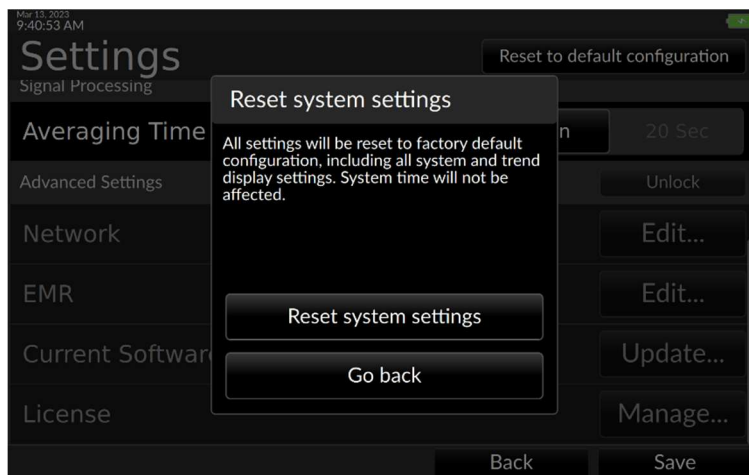

Fig. 2-79: Confirm reset to defaults

Confirming will reset all settings (except for system time) to factory defaults: including Trend selections, colors, display choices, parameter limits, graph ranges, time scales, and units.

Press *Reset System Settings* to reset to factory defaults. If the user does not wish to reset the device, press *Go back*.

2.11.6.3 Language, Date, and Time

The Language, Date and Time settings can be changed. Supported languages can be seen by pressing the *Language* button. English is the default language. During a monitoring session it is not possible to change the date and time. A red block of text will appear explaining this.

**CAUTION**

Time and Date cannot be changed while a patient is being monitored.

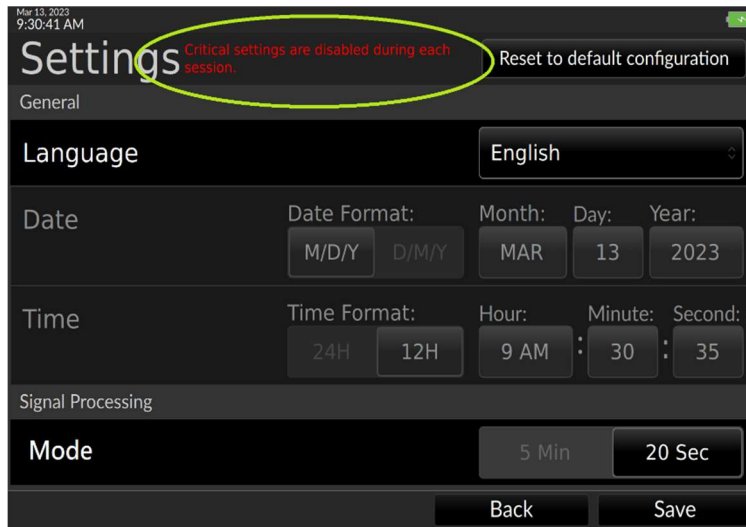

Fig. 2-80: The Settings menu (during patient monitoring session)

2.11.6.4 Monitoring Mode

The Argos offers two monitoring mode options, 5 minutes or 20 seconds. For both options, the display of each parameter value is a rolling average that is updated every 5 seconds. In the case of the 20 second option, rapid changes in the patient's hemodynamics will be reflected more quickly in the updated parameter display, whereas with the 5-minute option, hemodynamic changes will be reflected over a longer period of time. When monitoring the effect of an intervention, the user should take note of the selected monitoring mode.

After choosing the desired monitoring mode, press Save to return to the Trend Screen.

Advanced Settings

Advanced Settings allow the user to

- Configure the Argos EMR interface (Electronic Medical Record) compatibility for use with a particular EMR system
- Manage the software license key to enable purchased software options
- Perform software upgrades

**CAUTION**

Advanced Settings including License Management and Software Upgrade are designed to be implemented by Retia trained personnel in conjunction with the facility's IT department. Users should not attempt to change these settings. IT personnel should be trained by Retia and consult the relevant sections of this manual before accessing these settings.

Advanced Settings are a feature of Argos software versions 2.00 and above. Users of earlier versions should contact their Retia representative to learn about software upgrade options for their monitor. By default, Advanced Settings are locked. The software key needed to unlock Advanced Settings is available with a service contract. Only a Retia trained representative may install the software key.

Step-by-step guidance for configuring Advanced Settings are found in §4, Software Management.

2.11.6.6 Events

The Argos permits user notation and recollection of events via the Events popup on the Control Bar. To access Events, press the flag icon:



Fig. 2-81: Tap the flag icon to notate or recall events

The Events page appears with the Mark Event tab selected. A virtual keyboard allows entry into a text box, with the current time for logging the entry. Adjusters permit changing the marked time.

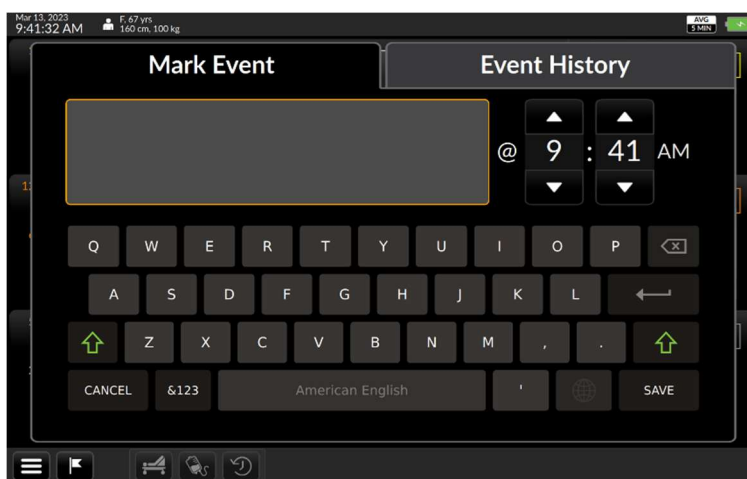

Fig. 2-82: Event marking screen, with Mark Event selected

Use the keyboard to describe the event. If the user needs to notate an earlier time, adjust the time using the triangle buttons.

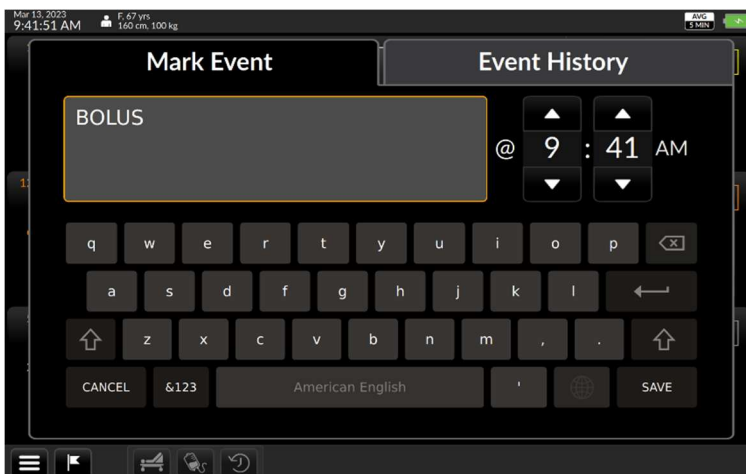

Fig. 2-83: Description of event

To save the event text, press *Save*. The Trend screen resumes. To recall events, press the *Event History* tab. All saved events appear in chronological order.

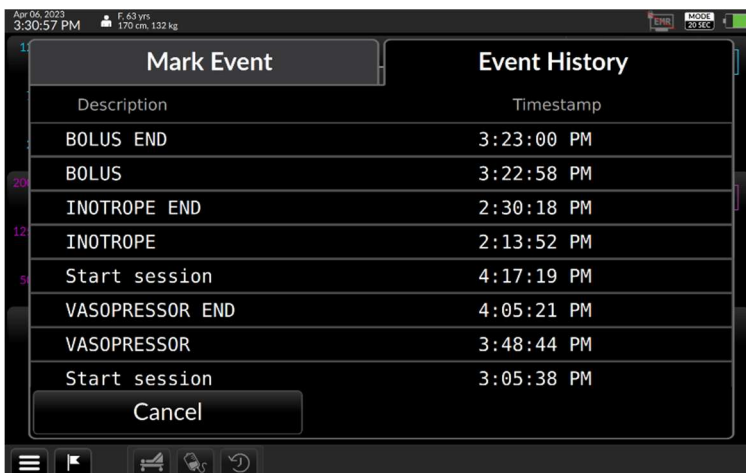

Fig. 2-84: The Event History tab

To edit an event, touch it in the chronology line. The *Event: Edit Event* screen appears:

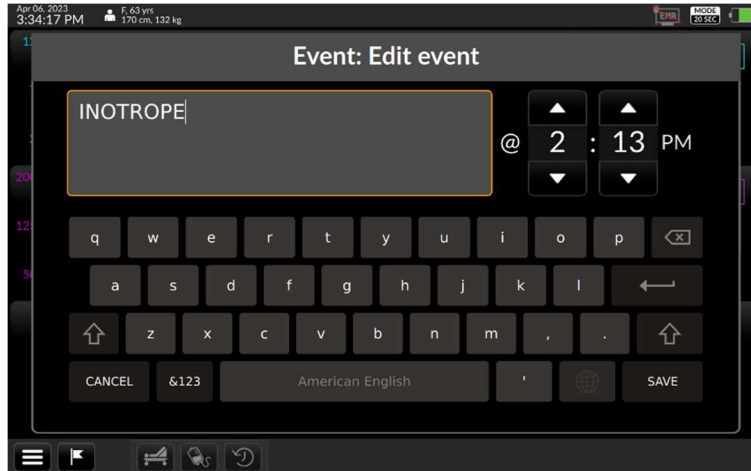

Fig. 2-85: Edit event

Here the user may alter text, adjust Event Time as desired, or use the keyboard to make changes. Press Save to commit the changes.

To return to the Trend screen from the Event History overlay, press Cancel. Flags representing the marked events appear on the trends.



Fig. 2-86: Press cancel to recall the Trend screen

2.12 Dynamic Assessment Functionality

The Dynamic Assessment feature guides the Clinician through a sequence of steps, providing instructions throughout the process to determine if a patient is likely to be fluid responsive or not. It consists of two stages. The first stage establishes a baseline. The second stage examines the percent change in SV or CO after an intervention. The Dynamic Assessment feature guides the clinician through these stages, providing instructions throughout the process.

2.12.1 Assessment types

The Argos supports two types of Dynamic Assessments:

- 1) a Passive Leg Raise (PLR)
- 2) a Fluid Bolus.

2.12.2 Canceling an Assessment

Once the user begins a fluid challenge, the user will not be able to switch between the challenge screen and the trend screen. The monitor will still be running in the background and the previously chosen parameters will always still be visible. However a Challenge can be canceled at anytime.

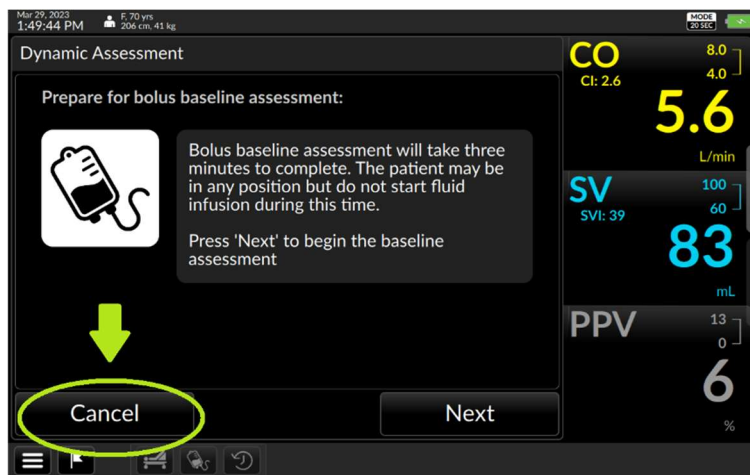

Fig. 2-87: Press cancel to end assessment and go back to trend screen.

If the user creates a baseline, but does not complete the assessment, an entry will be added to the Dynamic Assessment history showing an aborted challenge. If the user does not finish establishing a baseline, an assessment record will NOT be saved. To see more on the DA History go to section 2.12.5.

2.12.3 Fluid Bolus Assessment

The fluid bolus icon can be found on the bottom of the Control Bar. Press this icon to begin the Dynamic Assessment using fluid bolus.

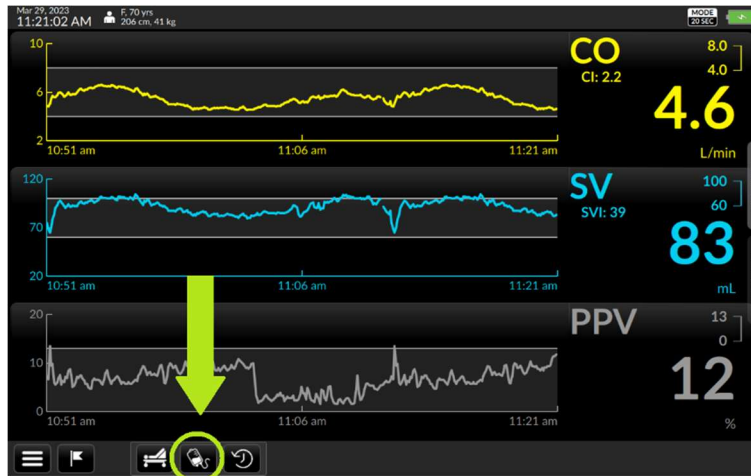

Fig. 2-88: Press the fluid bolus icon to start the challenge.

The user can choose between a 250ml bolus or a 500ml bolus.

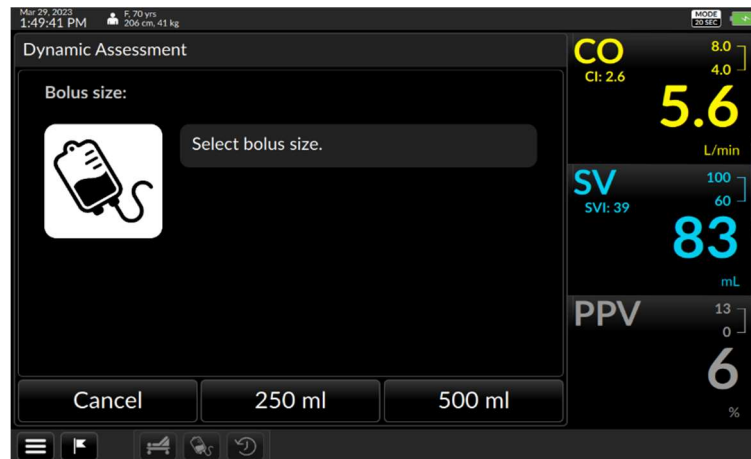

Fig. 2-89: Select between the two bolus sizes.

If the Argos cannot use existing data for a baseline due to fluctuations in the patient's hemodynamic status, the user will be brought to a screen that gives instructions on how to create a new baseline. When ready to begin the baseline, press "next".

- *Note the Argos is always calculating a rolling baseline of the patient in the background, so sometimes the Argos will already have a qualified baseline for the patient. If it does, the next screen will give the option to create a new baseline or use the baseline that was calculated in the background.*

The user begins by selecting the desired bolus size to continue. Press Next to create a new baseline.

**CAUTION:**

Once the user begins a fluid challenge, the user will not be able to switch between the challenge screen and the trend screen. The monitor will still display the parameters that have been previously selected. The trend screen cannot be accessed unless the Dynamic Assessment challenge is canceled. A challenge can be canceled at anytime.

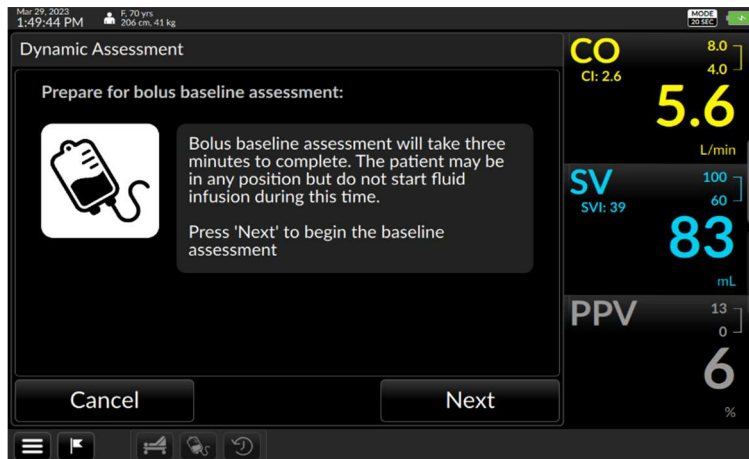

Fig. 2-90: Argos prompts to create new baseline.

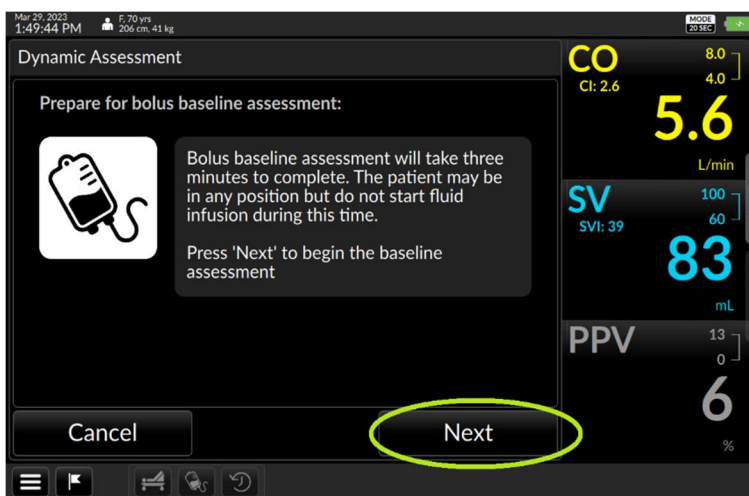

Fig. 2-91: Press Next to create new baseline.

A three minute timer will begin counting down. When the timer completes, a new baseline has been captured and the user will be brought to the challenge preparation screen.

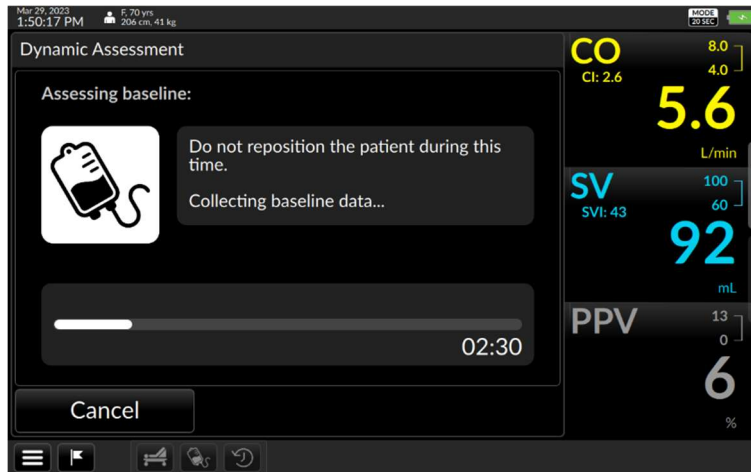

Fig. 2-92: 3 minute timer countdown to create baseline for bolus fluid assessment.

When the timer has finished the baseline is complete and the begin infusion screen will be presented.

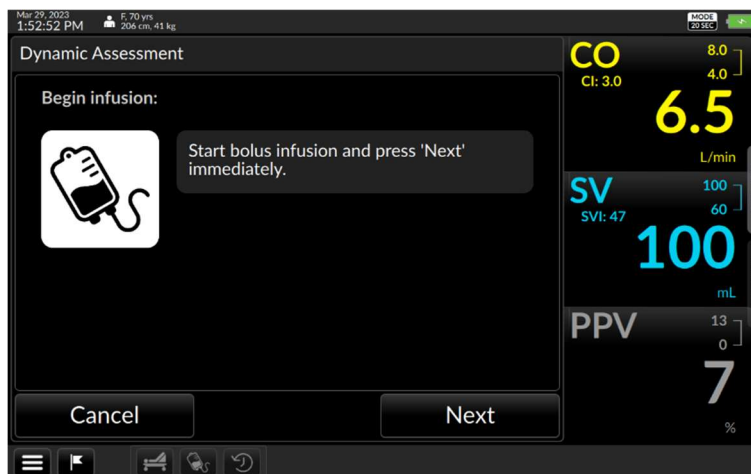



Fig. 2-93: Begin 250ml or 500ml Bolus infusion.

When the user is ready to begin the challenge, start the bolus infusion and immediately press *next*.

 **CAUTION:** Please ensure that the patient remains motionless to prevent the occurrence of an unstable baseline. For more information on unstable baselines, see section on unstable baselines.

A countdown timer will begin and the percent change from the baseline to the current SV reading will be displayed on the screen. When running a 250ml bolus, the countdown timer will run for 7 minutes.

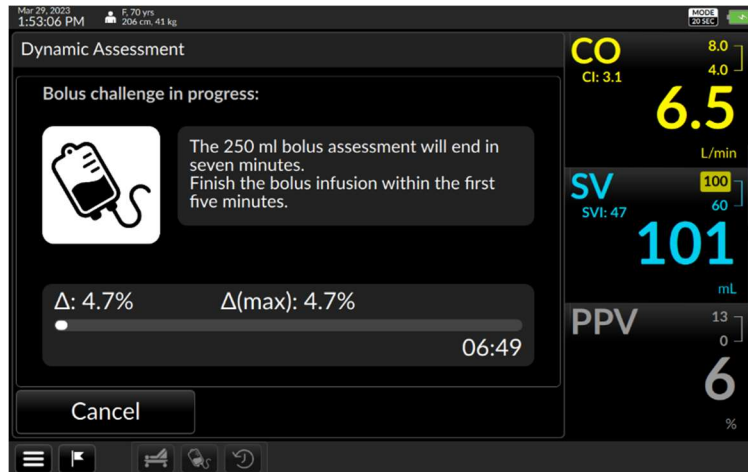

Fig. 2-94: 7 minute timer countdown for a 250ml bolus

A 500ml bolus will count down for 12 minutes.

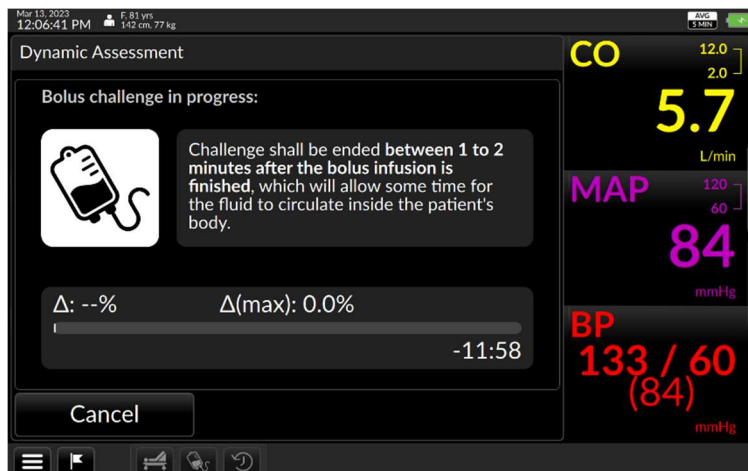

Fig. 2-95: 12 minute timer countdown for a 500ml bolus

If the percent change is equal to or greater than 10%, the assessment will end and show the report screen.

- Note that if ΔSV never reaches 10%, the countdown timer will continue until it reaches zero. When the timer reaches zero, the report screen will appear and show a likely non-responsive result.

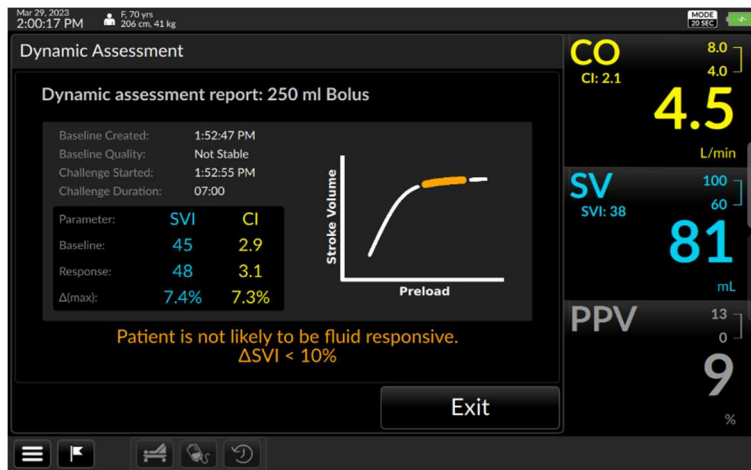

Fig. 2-96: Report shows that patient is not likely fluid responsive.

2.12.4 Passive Leg Raise (PLR) Assessment

A Passive Leg Raise assessment or a PLR is a noninvasive method to assess fluid responsiveness by raising the patient's legs 45°.

The Passive Leg Raise (PLR) icon can be found at the bottom of the Control Bar.



Fig. 2-97: Dynamic Assessment, PLR icon located on the Control Bar.

Once the User clicks on the PLR icon, the user will be brought to an instruction screen which will describe how to prepare the patient for a PLR baseline.

- Note the Argos does not maintain a rolling baseline in the background when doing PLRs. The patient needs to be moved into the correct position before capturing the baseline.

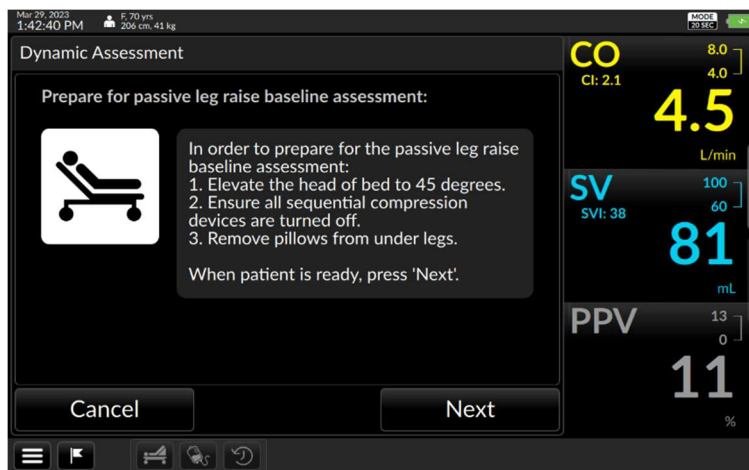

Fig. 2-98: Instruction screen to prepare patient for PLR assessment.

Once the patient has been positioned for the baseline, press *Next* to begin acquiring the baseline for the Passive Leg Raise Assessment.

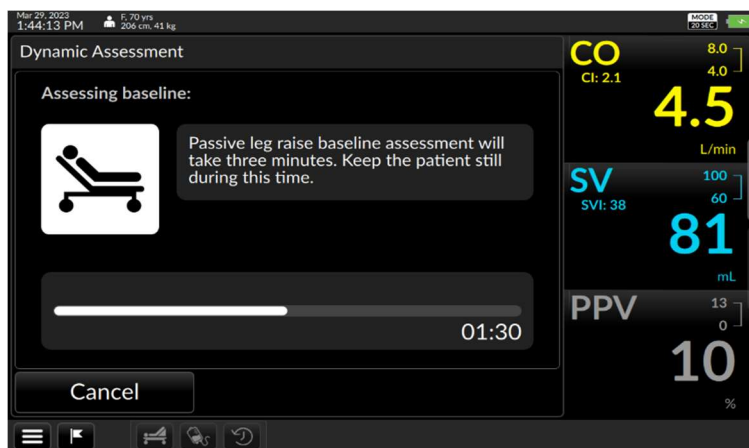

Fig. 2-99: 3 minute countdown timer to measure baseline for PLR assessment.



CAUTION: Please ensure that the patient remains still to prevent the occurrence of an unstable baseline. For more information on unstable baselines. See Baselines.

When the 3 minute timer has finished and a baseline has been acquired, the challenge screen will appear.

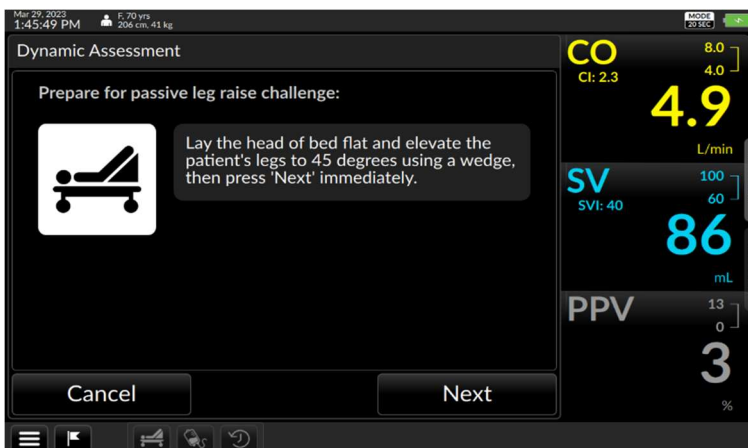

Fig. 2-100: Instruction screen to inform the user to raise patient's legs by 45°

Once the patient's head of the bed is flat and their legs have been elevated by a wedge to 45°, the user should immediately press *Next* to begin the Passive Leg Raise Assessment. The Argos will display a three minute countdown timer. The screen displays the percent change between the baseline SV and the current SV reading and the maximum percent change observed during the challenge.

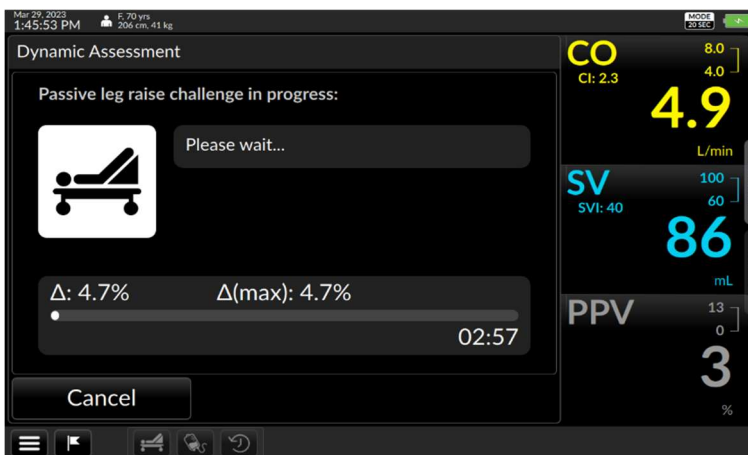

Fig. 2-101: PLR challenge screen which takes no more than 3 minutes.

If Δ SV is greater than or equal to 10%, the challenge will end immediately, and show a report screen indicating that the patient is likely fluid responsive.

If Δ SV remains below 10% for the whole three minutes, the challenge will end and show a report screen indicating that the patient is likely not fluid responsive.

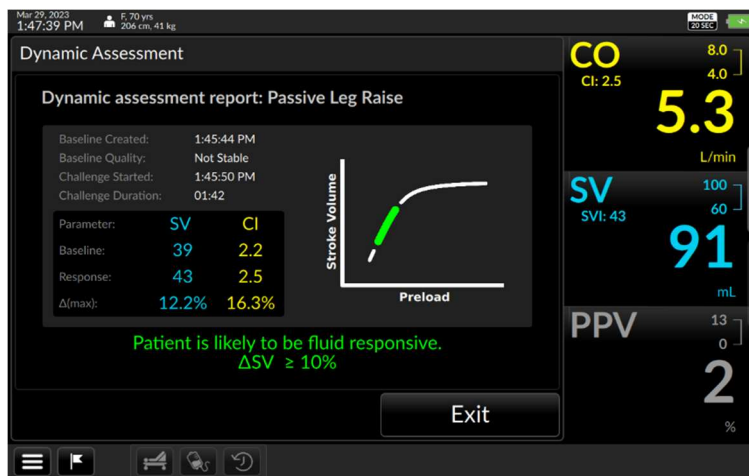

Fig. 2-102: PLR challenge screen reports that patient is likely fluid responsive.

2.12.4.1 Baselines

Baselines are calculated by taking the average of 3 minutes of data. The Argos categorizes baseline quality into four categories: stable, unstable, invalid, and expired. For technical details on how baselines are categorized please see Table 15.

2.12.4.2 Unstable Baseline

If the patient's Stroke Volume (SV) is highly variable or the patient is unable to remain motionless during the Bolus or PLR baseline assessment, the Argos will inform the user that the Baseline is unstable. This could potentially cause the Fluid responsiveness assessment to be inaccurate.

If the Argos detects an unstable baseline, it will notify the user and ask if the user wants to use the unstable baseline or establish a new one.

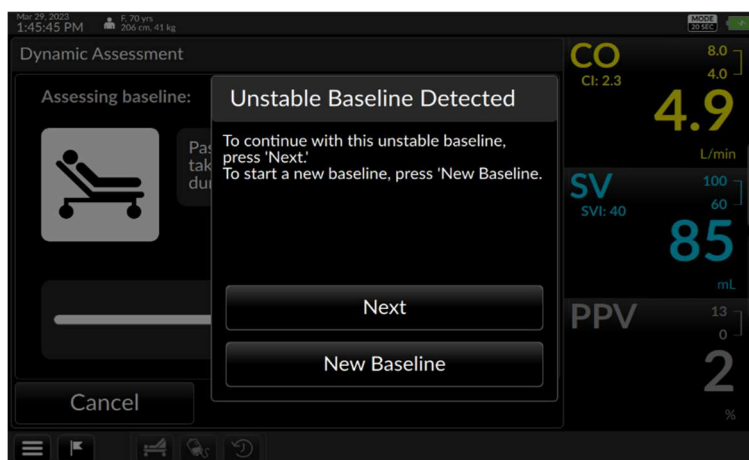

Fig. 2-103: Argos lets user know that the baseline is unstable.

The monitor is continuously maintaining the statistics for the baseline. If a period of time has elapsed and the baseline is no longer stable, then the user will be prompted to establish a new baseline by pressing *New Baseline*.

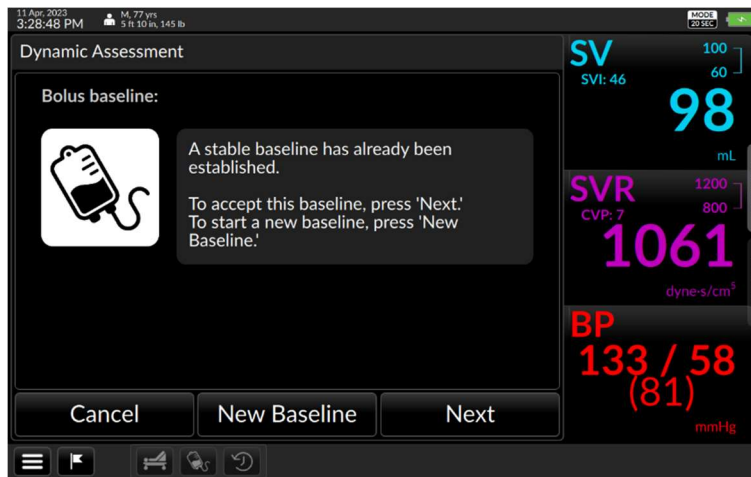

Fig. 2-104: Argos gives the user the option to use the existing baseline or to create a new one.

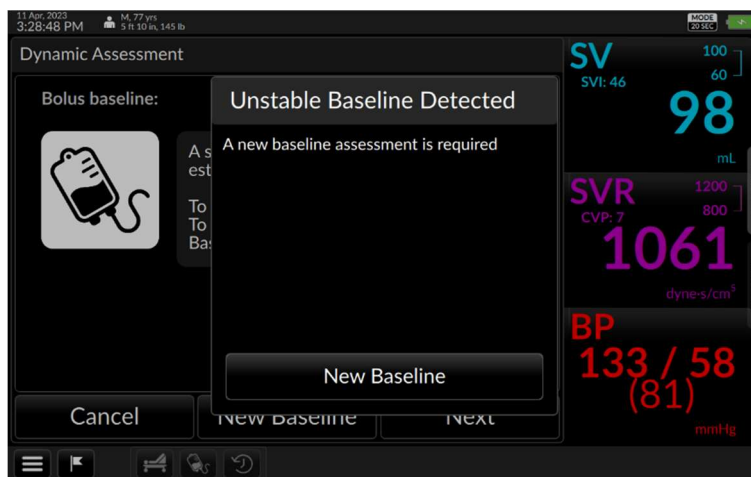

Fig. 2-105: Argos prompts user to manually create new baseline.

Invalid Baseline

If during baseline collection, the Argos is unable to obtain enough valid SV samples, a baseline is considered invalid. Invalid samples can occur if the BP signal is lost or there are fluctuations that prevent the monitor from gathering enough data to calculate SV.

Invalid samples are ignored when calculating percent change. If during the challenge there is no sample above the 10% threshold, the number of invalid samples is counted. If the challenge has been more than one third invalid samples, the result is considered invalid.

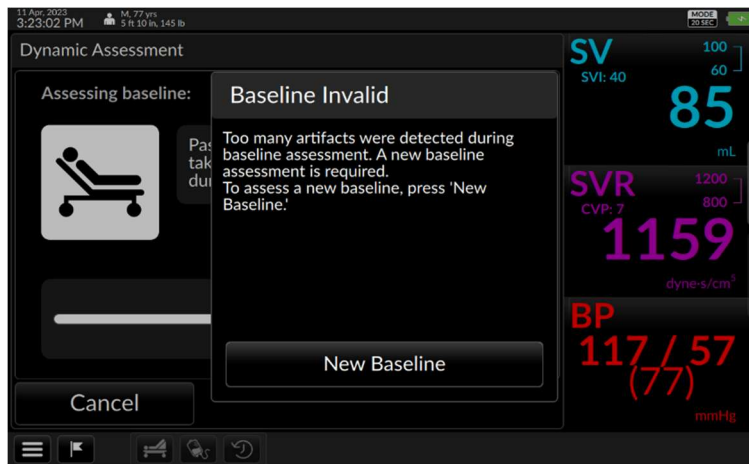

Fig. 2-106: Baseline rejected due to invalid samples



CAUTION!

Invalid samples are excluded from the average. If more than one third or 1 minute of the samples collected for calculating the baseline are invalid, the baseline will be considered invalid.

If the monitor shows that there is invalid data, the user should ensure the BP waveform is artifact free and that the connection from the Argos monitor to the patient monitor is stable. Rerun the baseline.

Expired Baseline

To maximize the quality of a dynamic assessment, the baseline and challenge stages should be run as close to each other as possible. An old baseline is less likely to accurately represent the resting state of the patient when the intervention is made. To ensure that the user does not accidentally use an old baseline, after 15 minutes the monitor will prompt the user to either establish a new baseline or agree to use the existing baseline.

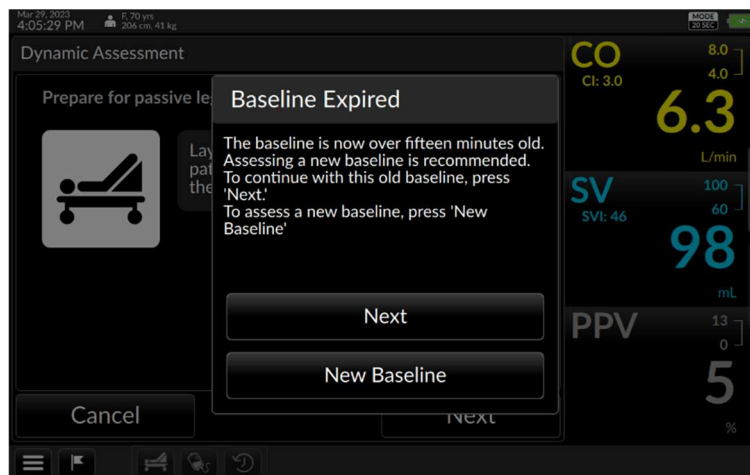

Fig. 2-107: Monitor prompts user that its baseline has expired since their baseline is over 15 minutes old.

2.12.5 Dynamic Assessment History

The Dynamic Assessment History icon allows the user to view all Dynamic Assessments from the current session. To access the Dynamic Assessment History screen, press the Dynamic Assessment History icon on the Control Bar.

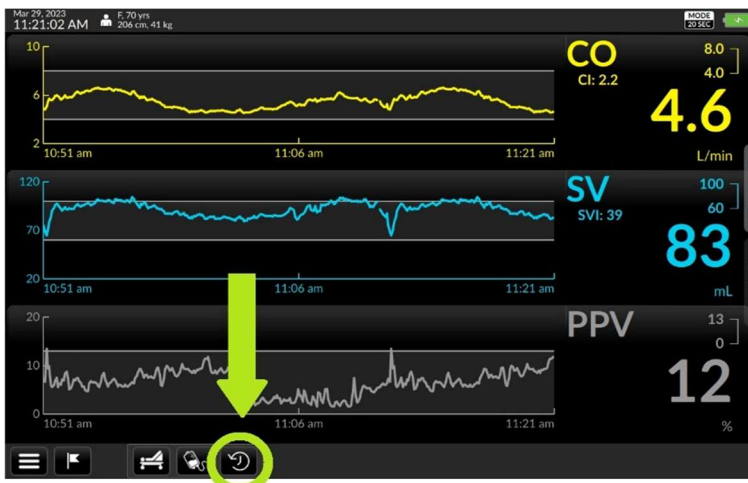

Fig. 2-108: Dynamic Assessment History Icon can be found on the Control Bar.

To view more information on previous assessments, tap on any of the previous dynamic assessments listed to expand it.



Fig. 2-109: Dynamic Assessment History performed during this session.



Fig. 2-110: Dynamic Assessment History entry expanded to show more details.

Table 5: Dynamic Assessment History Headers

Label	Description
Date	Date when the Dynamic Assessment was run
Challenge Type	Type of challenge. Can be PLR, Fluid Bolus 250, or Fluid Bolus 500
Baseline Quality	Indicates the quality of the baseline. (Notes if the baseline was stable, unstable, invalid, or expired)
Challenge Begin	At Time when the challenge began
Duration	Length of the challenge
Δ SV	Percent change of SV from the baseline to the maximum value observed during the challenge
Challenge Result	Result of the Challenge. Can be responsive, not responsive, or invalid

Date and Time indicator

Date and Time cannot be changed during a monitoring session.

2.14 Patient Demographics

Choose between metric and imperial when adding the patient during initial setup.

Patient information cannot be changed during a monitoring session.

EMR indicator *(licensed versions)*

Configured Argos monitors with a licensed upgrade show an interactive EMR status indicator at the top right of the screen beside the monitoring mode indicator.

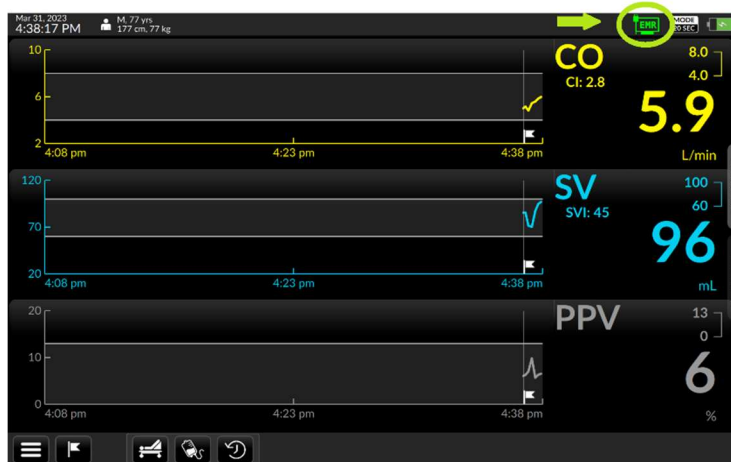

Fig. 2-111: EMR indicator

Table 6: EMR status icons

EMR Status	Icon
EMR connectivity normal	
Cannot connect to server	
Network unavailable	

Press and hold the EMR indicator to display a popup with further information:

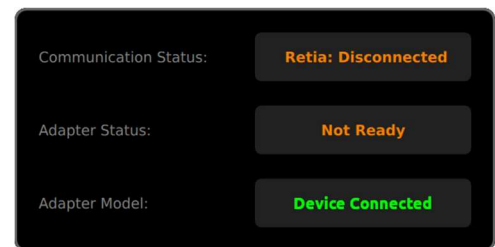
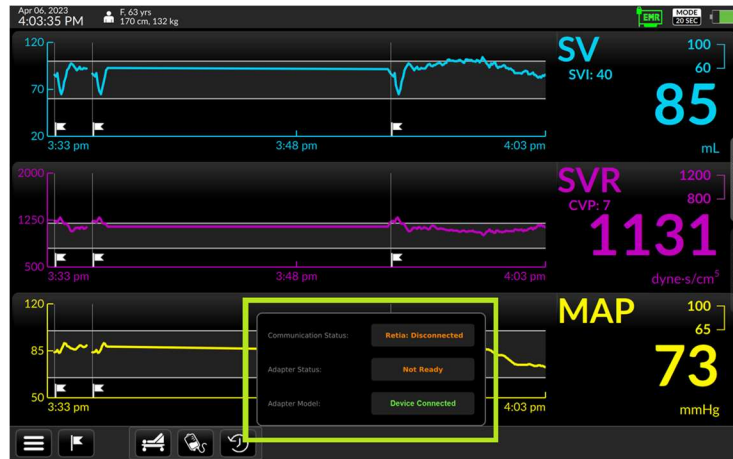

Fig. 2-112: EMR connectivity details

Release to dismiss the popup.

More information on EMR connectivity is detailed below in §3, p. 87, **EMR Integration**.

2.16 Monitoring Mode of Operations

Default monitoring mode is 20 seconds. Monitoring mode may be changed to 5 minutes in the Settings page (see §2.11.6.4, p. 67).

No Signal Detected timeout

In order to prevent accidentally continuing a previous patient's monitoring in the event the previously monitored patient was not discharged from the monitor and a new patient installed, after 30 minutes of the absence of a blood pressure signal, the Argos software will notify the user of the absence of a BP signal:

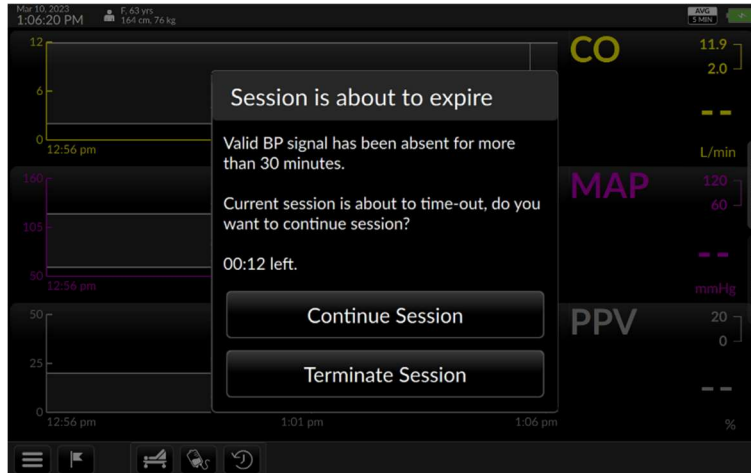

Fig. 2-113: No BP signal detected warning

If the notification has not been acknowledged after an additional 30 minutes, the software automatically stops recording to the database and discharges the patient, and the monitor returns to the Enter Patient Data screen (§2.5). This ensures if a new patient is admitted to the Argos monitor the associated demographic information will reflect only that patient's data.

3 EMR (Electronic Medical Records) Integration

Hemodynamic data collected by the Argos monitor can be delivered to an electronic medical record keeping system. This feature is available with a software license.

- ▶ *The Argos can download patient demographic data from a Corepoint server.*
- ▶ *To date the monitor has been configured to send data to a Philips Capsule server, Philips Capsule Neurons and Axons, Masimo (formerly Nant Health) server and the Philips Intellivue Monitor.*
- ▶ *When EMR capability is being used, it is the operator's responsibility to enter the correct Patient ID to ensure continual updating of the EMR database. In case of error or interruption of the EMR connection, the Argos will continue updating monitoring records locally.*

Since the Argos monitor uses industry standard HL7 protocols for communication, it can be configured to work with compatible systems. Because software development may be required, please consult with a Retia Medical representative when planning an installation into the hospital's Electronic Medical Records (EMR) system.

Hardware Requirements:

EMR integration via Ethernet requires the Argos LAN Connectivity Kit (p/n FG-008) which provides for connection of the Argos Monitor to the local area network (LAN) within a hospital, allowing the Argos Monitor to communicate with EMR servers and transfer hemodynamic data on a minute-by-minute basis.

EMR integration using a serial interface requires the Argos Serial Connectivity kit (p/n FG-009) which provides for connection of the Argos Monitor to a serial device which sends the data to an EMR system.

FG-008: Network Connectivity Kit with Ethernet adapter and network galvanic isolator with cabling. (For interfacing with the Capsule Ethernet or Masimo data interfaces.)

FG-009: Serial Connectivity Kit with cabling (For interfacing with the Philips EC10 monitor interface or a Philips Capsule Neuron or Axon)

Information on updating and configuring the Argos software to enable communication with EMR systems is available in §4, Software Management.

3.1.1 Entering Patient Data (*Licensed Version – Corepoint*)

If the device license has been activated (§4.1.1) and Corepoint data server connectivity has been configured correctly (§4.4.1.1), the Add Patient Data screen offers a patient search box.

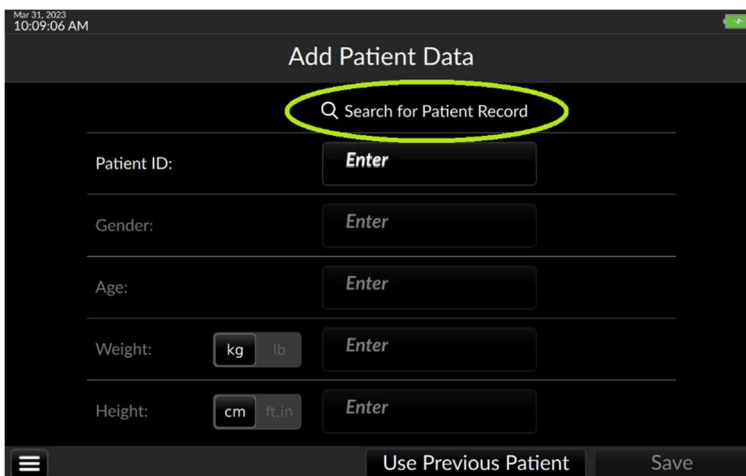

Fig. 3-1: Add Patient Data screen with Search for Patient Record

Touching inside the search box brings up an alphanumeric keyboard.

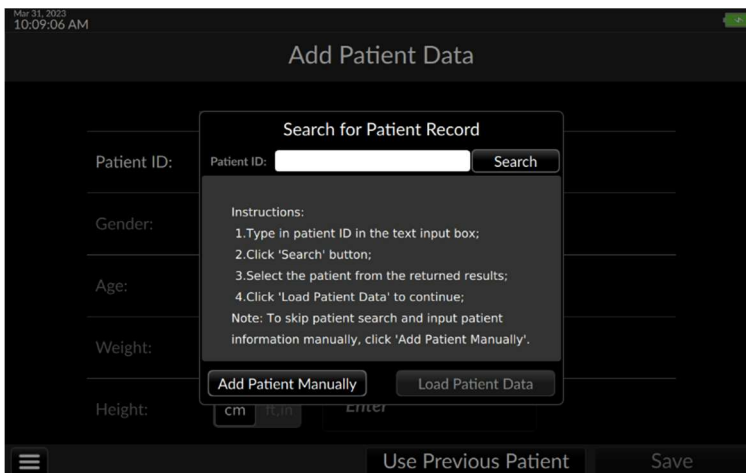

Fig. 3-2: Patient record search

Key in the patient ID assigned by the hospital, then press Search, or the return button on the virtual keyboard.

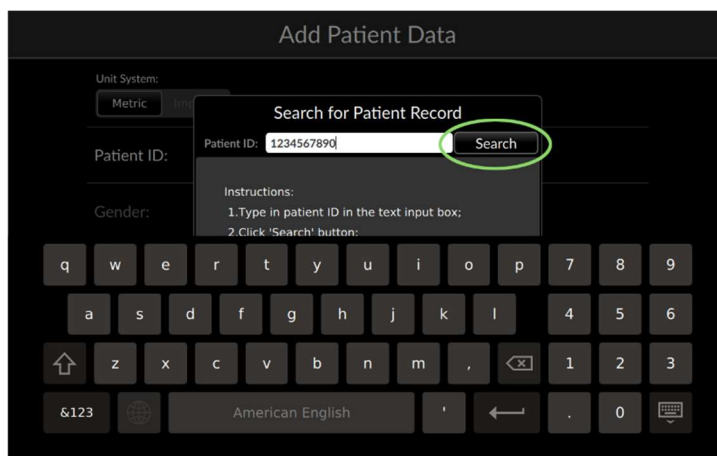

Fig. 3-3: Press Search after typing in the patient record

When the Patient ID is found, the record appears.

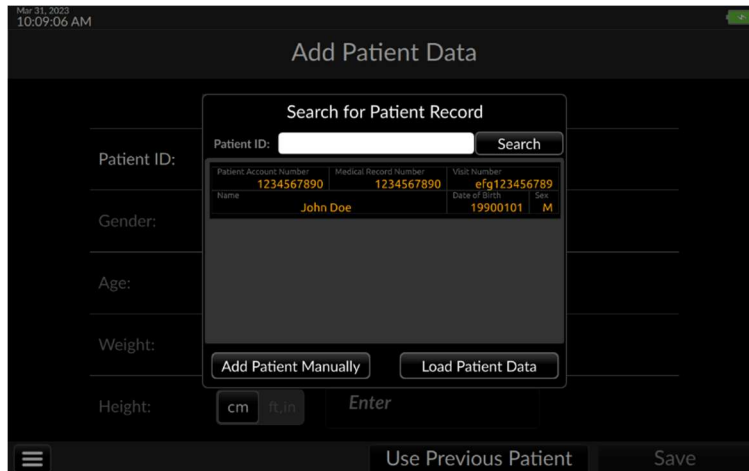

Fig. 3-4: Patient record located

Touch the Load Patient Data button. The Argos connects with the patient record database in order to confirm the patient's identity and details as input are correct.

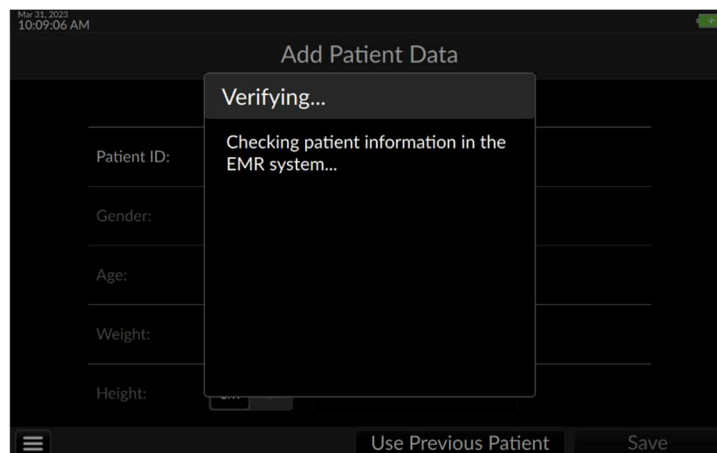

Fig. 3-5: Verifying patient details with the EMR server

Patient ID, Gender, and Age are shown on Add Patient Data screen. Verify the patient demographic information is correct.

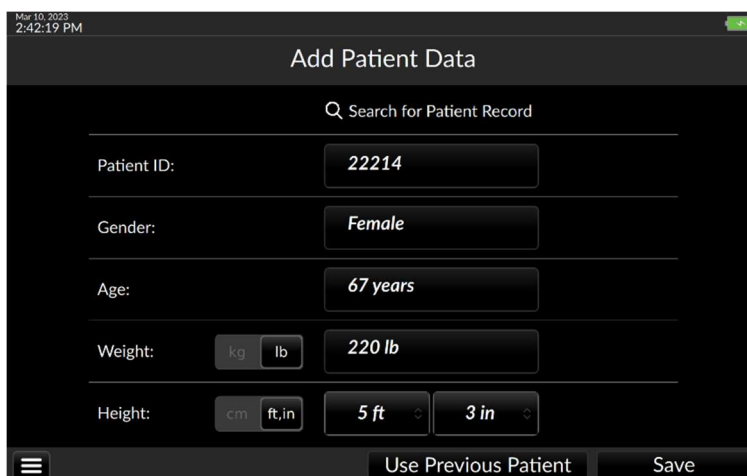

Fig. 3-6: Add patient weight and height, then press Save

Once Save is pressed, the Select Blood Pressure Signal Source screen appears. Monitoring may be initiated following selection of the signal source.

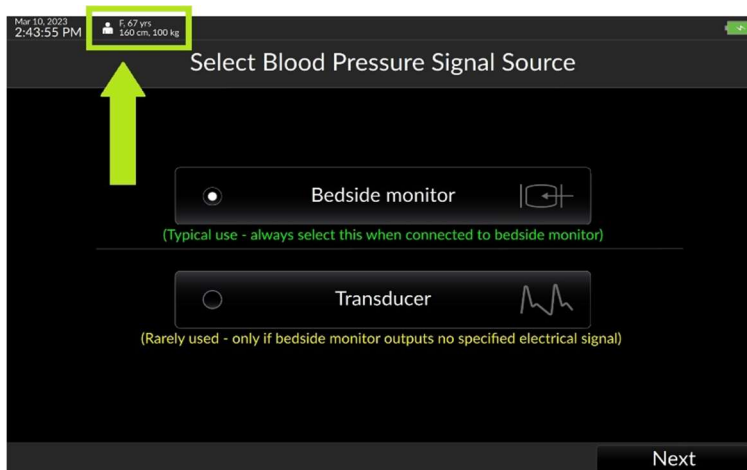

Fig. 3-7: Patient demographics loaded, ready to proceed with monitoring

If no Patient ID is found in the Corepoint database, or there is no connection to the server, a popup offers the choice between saving the previously entered patient ID to the Add Patient Data page or starting over with a new search.

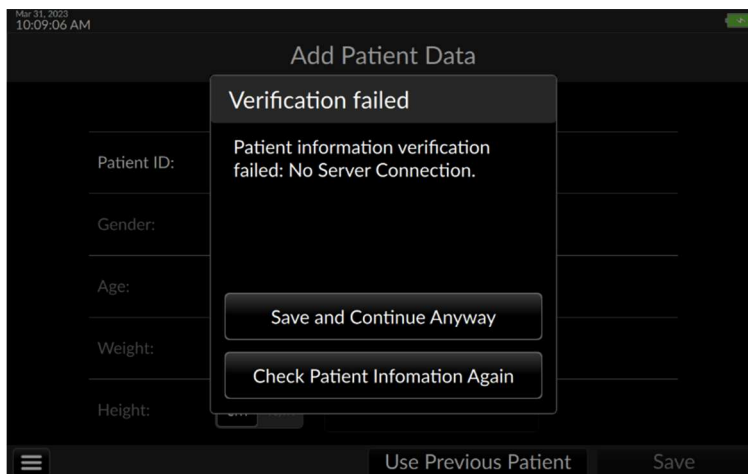



Fig. 3-8: Patient verification failed

If the search fails again after the operator has entered all the patient's ID and demographic information manually, pressing Save and Continue Anyway will save the manually entered information locally to the device and allow for monitoring without delay.

Software Management



CAUTION

Advanced Settings including License Management and Software Upgrade are designed to be implemented by Retia personnel in conjunction with the facility's IT department. Users should not attempt to change these settings. IT personnel should be trained by Retia and consult the relevant sections of this manual before accessing these settings.

4.1 Activating Advanced Settings

Advanced Settings allow Retia authorized personnel to: Install the licensed version of the Argos software Enable (or disable) and configure EMR (Electronic Medical Records) integration for licensed monitors, including network settings (*Licensed devices only*).

To activate Advanced Settings, first open the Settings screen from the menu icon (§2.11.6.1, p. 65). Swipe up the center of the screen or use the slider bar on the right side of the screen to show the Unlock button to the right of "Advanced Settings." Note that if Advanced Settings are locked, settings entries below it are dimmed.

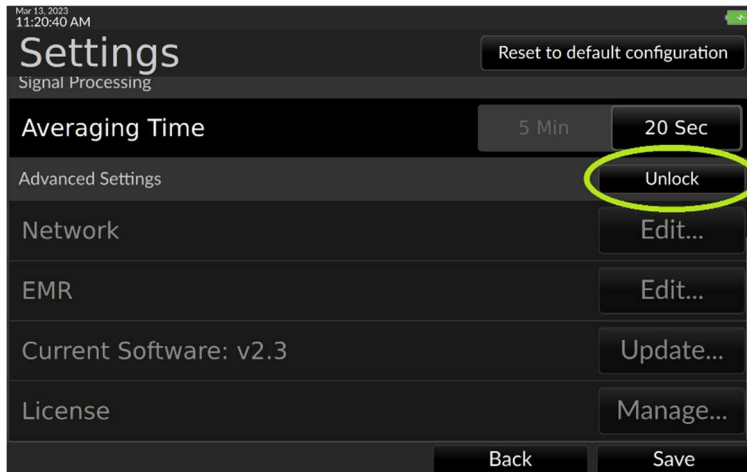

Fig. 4-1: Touch Unlock to open Advanced Settings

Touching Unlock brings up a confirmation screen.

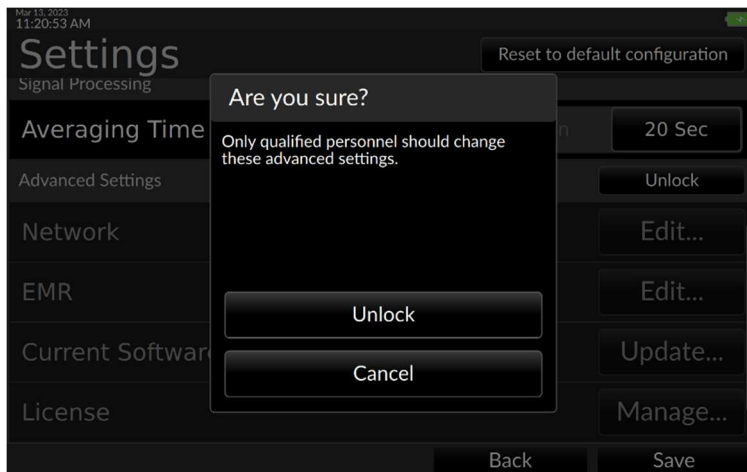

Fig. 4-2: Confirm the user is qualified to change Advanced Settings

Confirm by pressing Unlock. The Advanced settings screen opens.

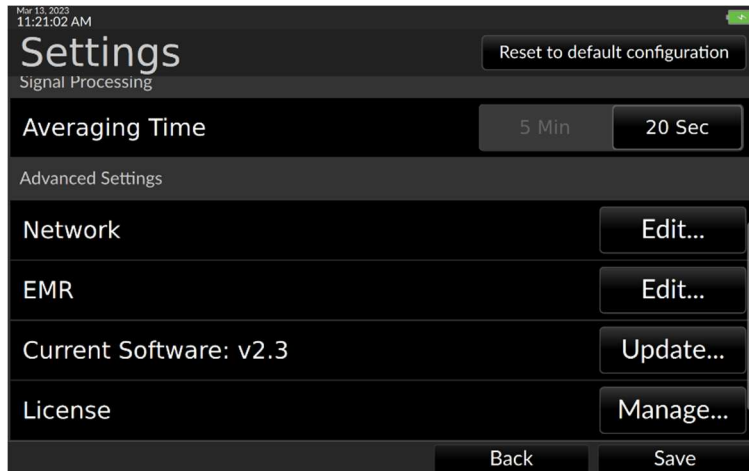

Fig. 4-3: Advanced settings, top of screen

4.1.1 Installing the software license to enable EMR

EMR connectivity requires a software license key provided by a Retia representative. This license enables an Advanced Settings screen for configuring EMR interoperability.

- ▶ *The software license can only be installed on Retia Argos monitors using software version 2.00 or later. If the monitor uses any 1.XX version, contact Retia to upgrade the system software.*

4.1.2 Verifying the software license has been installed

To verify whether the device is licensed to enable EMR connectivity, navigate to the Advanced Settings page: open the Settings screen from the menu button on the far lower left of the screen and swipe up the center of the screen or use the slider bar on the right side of the screen to show the "Advanced Settings" title next to the "Unlock" button:

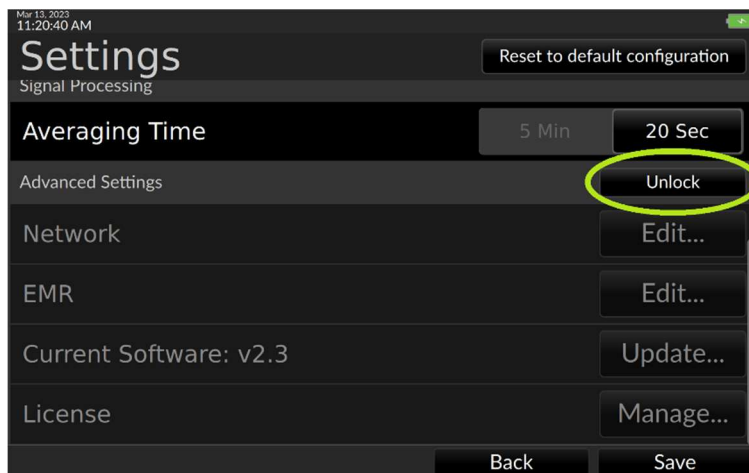

Fig. 4-4: Press Unlock to access Advanced Settings

Press the unlock button. A confirmation screen appears.

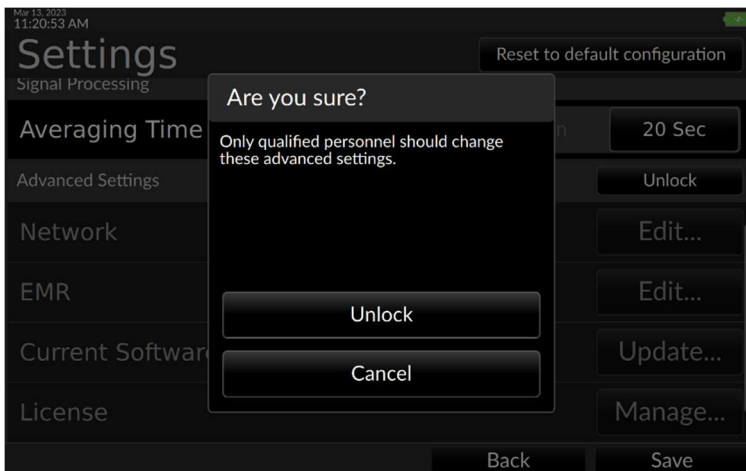

Fig. 4-5: Confirm access to Advanced Settings

Once Advanced Settings have been enabled, settings are undimmed. Press the Manage button to the right of the License entry:



Fig. 4-6: Press Manage to verify EMR status

If licensed, the popup displays license details.

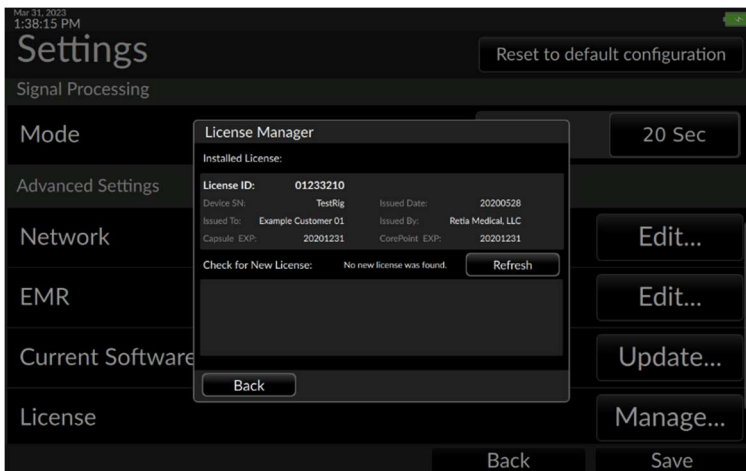

Fig. 4-7: License Manager display of licensed device information

If the device is not presently licensed and no USB license key is in the drive, the License Manager indicates Not Found.

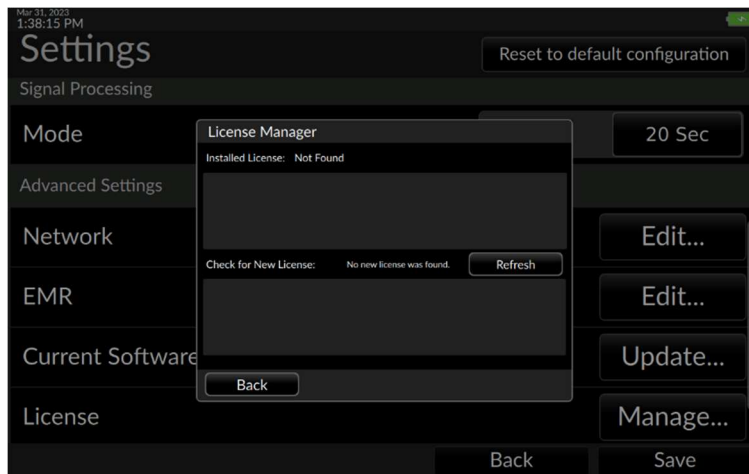

Fig. 4-8: Installed license not found

License installation

Insert the USB license key into one of the Argos's data ports and press the Refresh button next to the Check for New License menu entry. Details of a valid software license will show in the lower pane of the License Manager window.

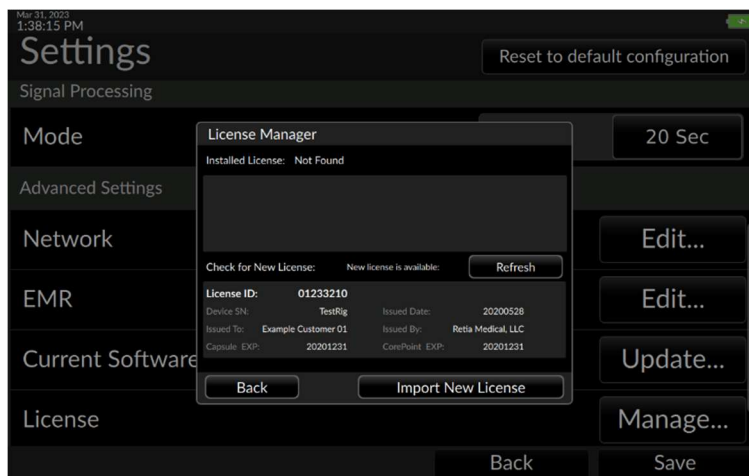

Fig. 4-9: License ready for installation from USB drive

Press "Import New License" to load the license into the Argos.

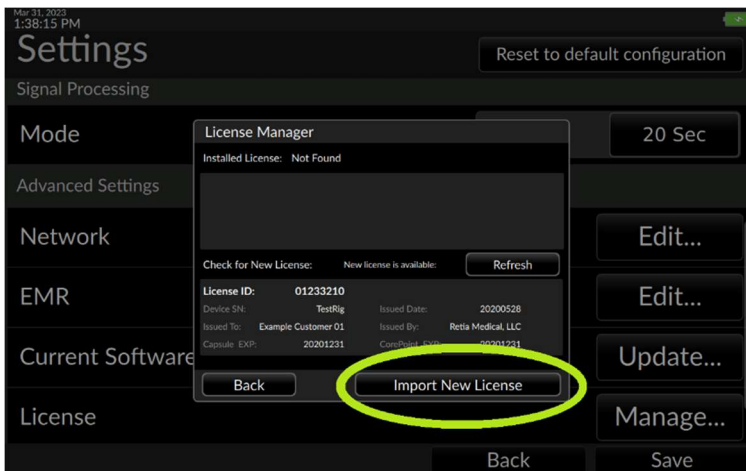

Fig. 4-10: Press Import New License

A notification that the license has been successfully imported appears.

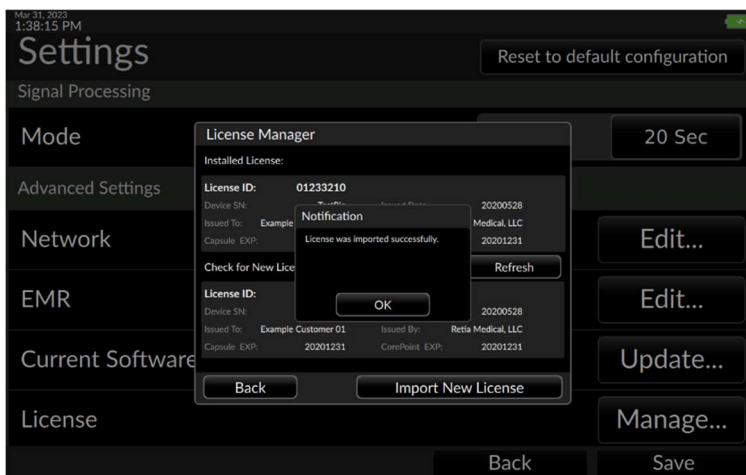

Fig. 4-11: Software license successfully imported

Remove the USB stick. To verify the license has been installed, touch Back, then from the Advanced Settings page press the License Manage... button. License details will now display in the upper panel of the License Manager popup.

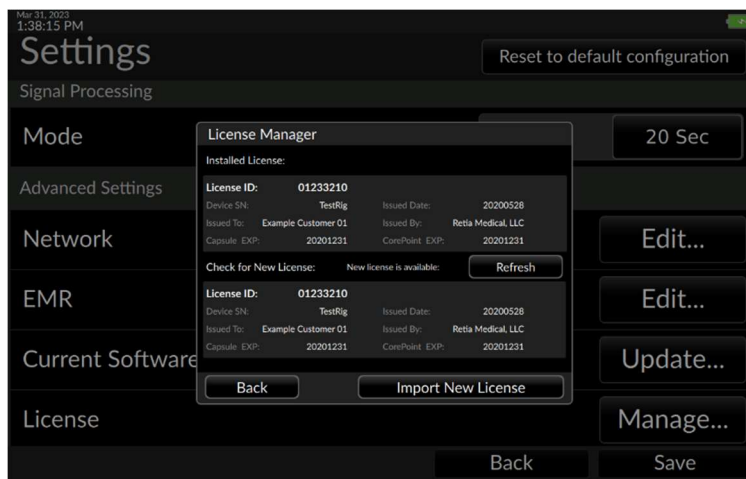

Fig. 4-12: License information displayed in License Manager

4.1.4 Configuring EMR service connectivity

EMR capability requires

- Software version 2.0 or higher
- A valid software license
- The Retia Argos LAN Connectivity Kit (P/N FG-008)
- Or:
- The Retia Serial Interface Connectivity Kit (P/N FG-009)

The Argos can connect directly to a monitor (Philips Intellivue) or to a Philips Capsule Neuron or Axon via a serial connection using the FG-009 Serial Connectivity Kit or to an EMR platform that resides on a TCP/IP network using the FG-008 LAN Connectivity Kit. In either case an EMR software license is required.

Philips Monitor Settings

To configure the Argos monitor for use with the Philips IntelliVue Monitor the user will need the following hardware:

- A Philips EC10 built in, or an EC10 module that supports the Philips IntelliVue Open Interface (consult a Philips representative).
- A Philips EC5 interface model number 865114 option #104 (consult a Philips representative).
- The Retia FG-009 Serial Connectivity Kit (consult a Retia representative).

From the settings screen select the EMR Edit button and select "Philips" from the drop down list and press save.

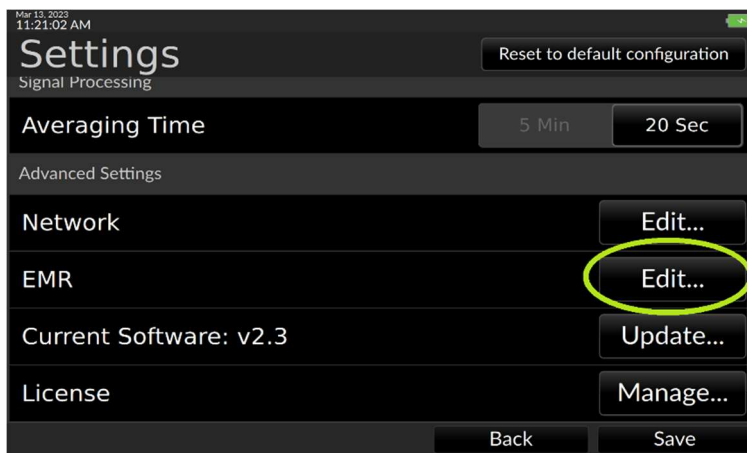

Fig. 4-13: Selecting the Philips Monitor Connection...

Once this is selected and the Philips EC5 is plugged into the Retia FG-009 and the Philips EC10 the rest is automatic. The User can verify the functional state of the connection by pressing the “EMR” button that appears on the lower right side of the Argos screen. It takes approximately one to two minutes for the connection between the Argos monitor and the Philips monitor to be established.

4.2.1 Troubleshooting the Philips Monitor Connection

If the Argos is not connected to the FG-009 the Adapter model will show “Adapter not found”. Make sure the FG-009 adapter is plugged into one of the USB ports on the side of the Argos monitor as described in the FG-009 Setup Instructions (60-037 Serial Connectivity Kit Setup Guide that comes with the FG-009).

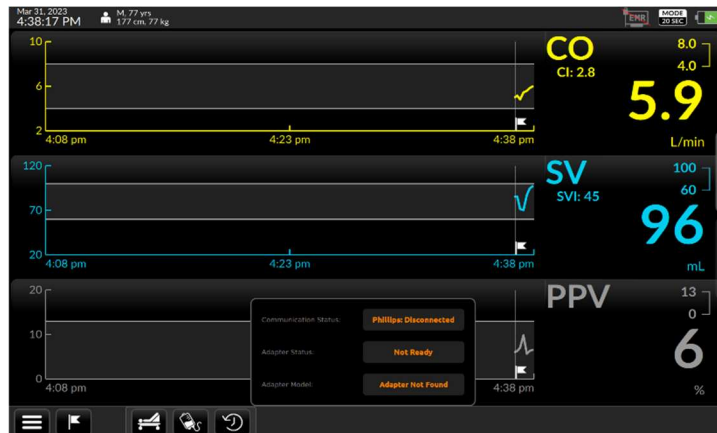

Fig. 4-14: Connection Status for Philips Monitor Showing no FG-009 Connected

Once the FG-009 is properly connected to the Philips EC5 and the Philips EC5 is properly connected to the Philips EC10 module, the user should see “Philips: Connected” in the Communication Status row as shown in figure 8-127. The user can also verify the connection status from the EC10 module LED indicator: A blinking indicator indicates the Argos monitor is detected and communicating.



Fig. 4-15: Connection Status for Philips Monitor Showing Full Functionality

Once connected to the Philips monitor, the hemodynamic data (CO, CI, SV, SVI, SVR, SVRI, PPV) are able to be viewed on the Philips monitor as C.O., C.I., SV, SI, SVR, SVRI and PPV respectively. If connected to an EMR these variables will be sent by the Philips monitor to the EMR.

Network Settings

From the Advanced Settings window (§4.1) press Edit to the right of the Network entry in the Settings menu.

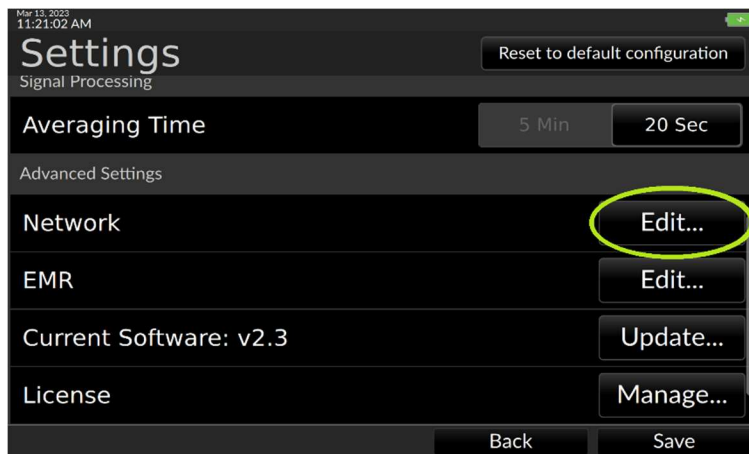

Fig. 4-16: Select Network/Edit...

The Network screen offers the choice between Automatic IP addressing (if a DHCP server is on the network) or manual addressing. Automatic IP addressing is selected by default.

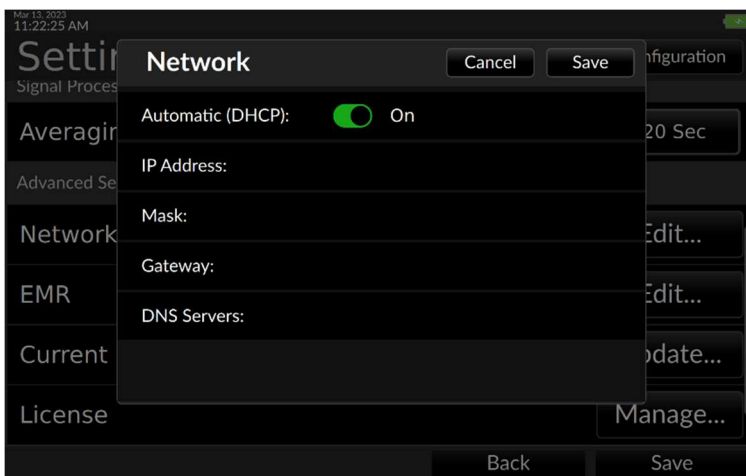

Fig. 4-17: Automatic (DHCP) addressing shown selected

If a DHCP server is present, leave Automatic (DHCP) selected. If there is no DHCP server, the user must configure network settings manually. First, move the slider button to switch off DHCP.

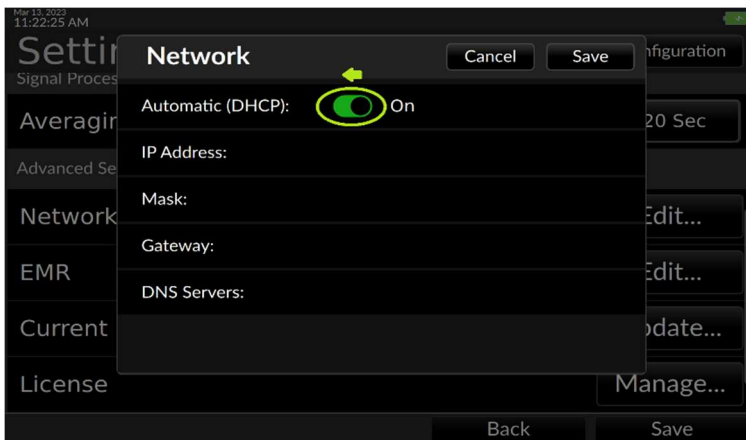

Fig. 4-18: Move the slide to switch off DHCP

The network settings will populate with sample values for editing.

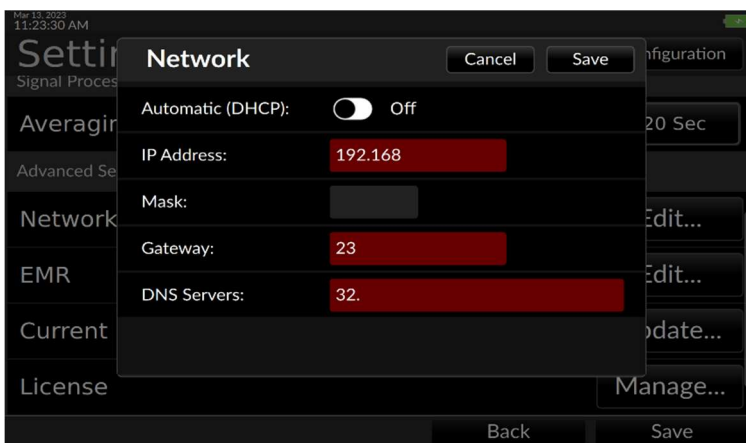

Fig. 4-19: Sample DHCP values filled in

Touch inside the entry fields to summon the virtual keyboard.

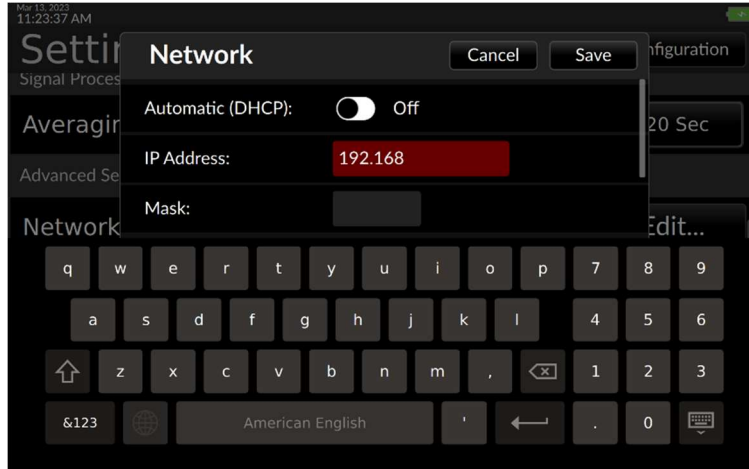

Fig. 4-20: Use the keyboard to enter network values

Configure the IP address, mask, gateway and DNS server as specified by the facility's IT department.

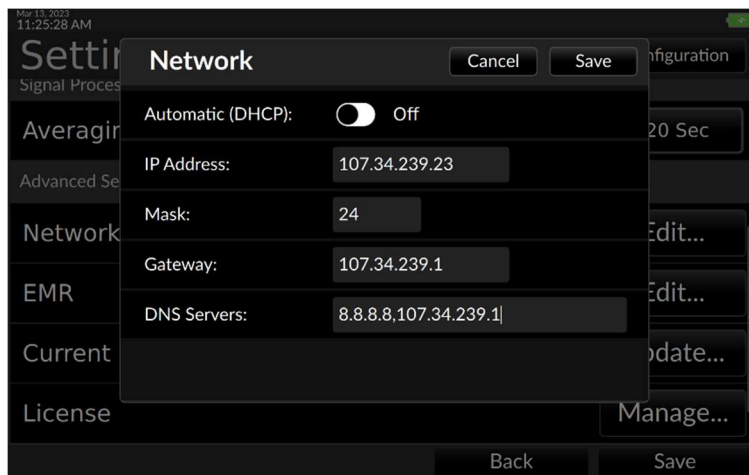

Fig. 4-21: Network settings

Close the dialog to return to the advanced settings page.

4.4 Configuring *EMR service*

4.4.1 EMR Platform

The Argos can push data to a data concentrator or service for a particular patient based on the patient ID used by the EMR system.

HL7 based interfaces use the PCD-01 Transaction format: Device Observation Reporter → Device Observation Consumer. Alarm data for Argos alerts are sent in compliance with the PCD-04 Report Alarm transaction format: Alarm Reporter → Alarm Manager.

Current systems supported are:

- 1) Philips Capsule – via Ethernet or Serial
- 2) Masimo – legacy iSerona
- 3) Philips IntelliVue Connection

4.4.1.1 Patient Record Query

From a Patient Record Query server the Argos will attempt to receive the patient's age, gender, height, and weight. This ensures faster, less error-prone setup for the hemodynamic parameters the Argos requires to correctly calculate values and indices. The Argos monitor currently supports the following servers:

- 1) Corepoint

4.4.2 Adding EMR Server Entries

Proceed to the Advanced Settings screen (§4.1) and press "Edit" to the right of the EMR entry.

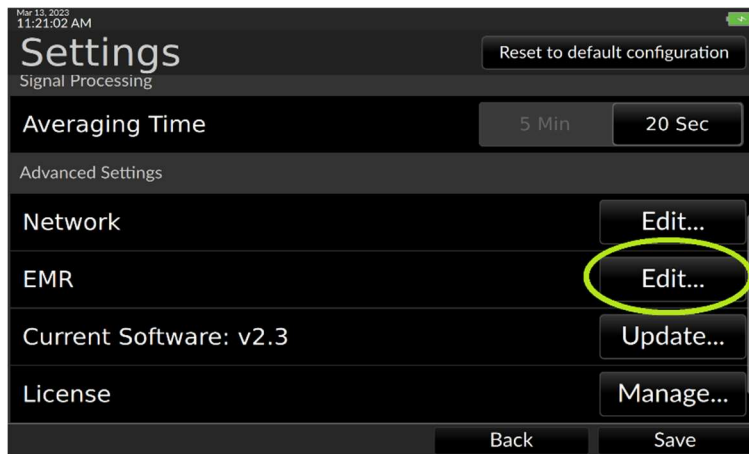

Fig. 4-22: Select EMR/Edit...

The EMR Settings screen appears.

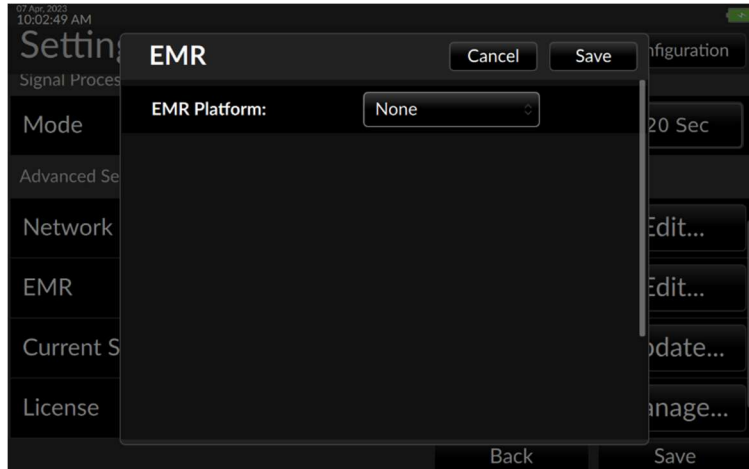

Fig. 4-23: The EMR Settings screen

Touching the box beside EMR Platform activates a drop down menu listing server choices. Various configuration options will appear in the dialog based on the selected EMR Platform. Network based platforms will require the entry of the target server's address and port. Interfaces based on HL7 require a setting for the sending and receiving facilities.

"Sending Facility" is an identifier for the monitor where the data is being captured: the user may want to put the hospital bed or room number where the monitor is located. "Receiving Facility" is where the destination EMR server is located: the facility's name is one suggested value.

Select the facility's server: here, Capsule Ethernet is selected.

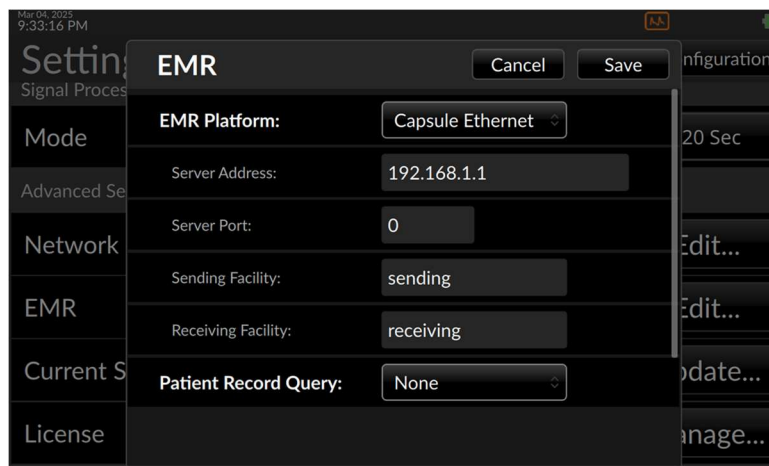

Fig. 4-24: Capsule server shown selected

The Capsule Ethernet interface has the ability to pull demographic information from a Corepoint server. To configure the Corepoint connection, select Corepoint under the Patient Record Query drop down menu. Proceed to the Patient Record Query server settings by pulling down the right-hand slider bar.

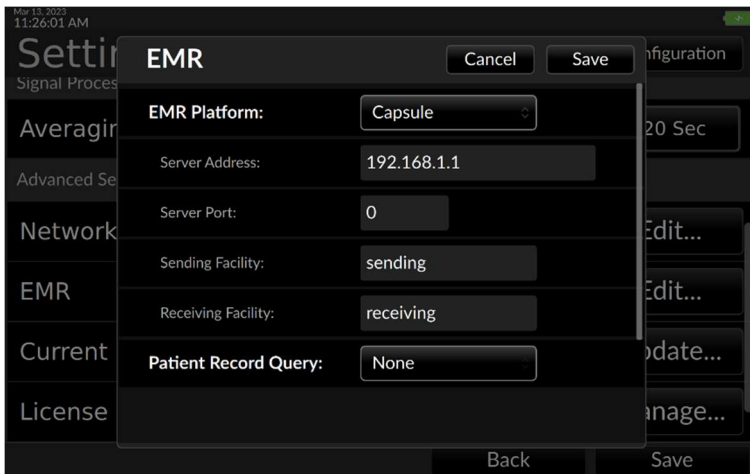

Fig. 4-25: Enter EMR server information

Fill in the Server Address, Server Port and Sending Facility and Receiving Facility for the server, in this case Corepoint.

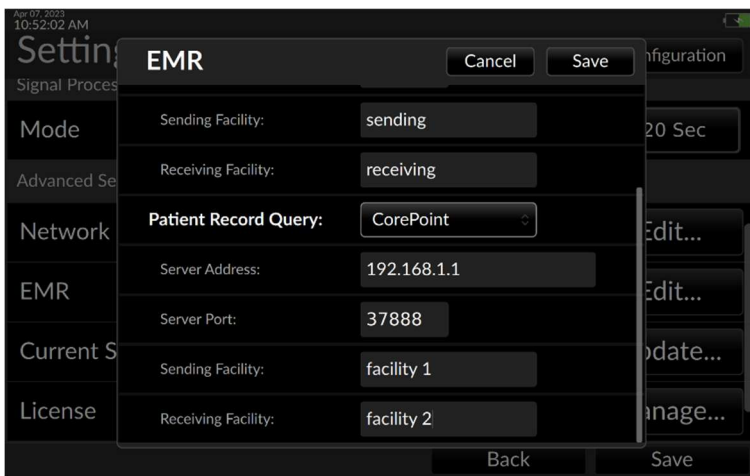

Fig. 4-26: Edit Patient Record Server details

- ▶ When Patient Record Query is configured to work with Capsule, the receiving facility must be set to "Capsule1" to enable receipt of data.

When the user has finished entering EMR parameters press "Save." The Argos is now able to communicate with the facility's EMR servers.

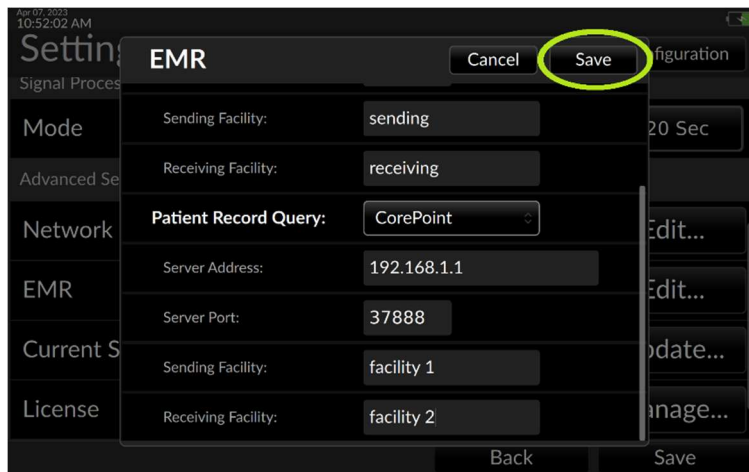

Fig. 4-27: Press Save to save and close EMR configuration

4.5 Updating the software

The software on the Argos monitor can be upgraded using a USB memory stick, coded to the device's serial number. (Multiple monitors may only be upgraded with individual memory sticks.) A Retia sales representative can get the appropriate software upgrade if the monitors are covered under the maintenance plan.



CAUTION

Software upgrades may ONLY be performed by a qualified Retia trained individual.

To start the upgrade, place the memory stick in one of the USB slots on the side of the monitor. Go to the Settings menu and select Advanced Settings (§4.1). Touch the Update... button.



Fig. 4-28: Touch Update

The Argos will read the USB stick and, if a properly formatted USB drive containing the upgrade is found, prompt for confirmation. Select Install to continue.

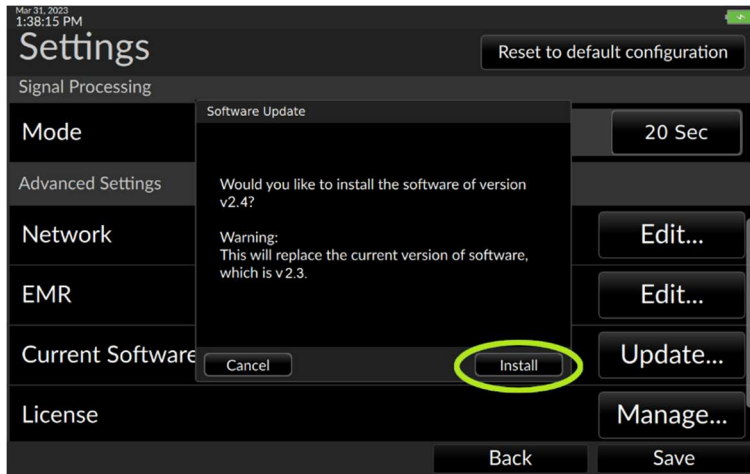

Fig. 4-29: Select Install to proceed with the software upgrade

The upgrade process begins. A bar displays the upgrade progress. When the upgrade is completed, the user is prompted to remove the USB drive.

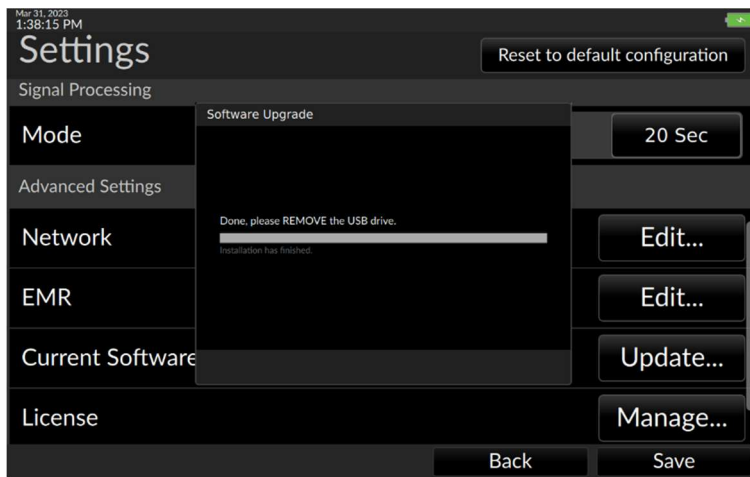

Fig. 4-30: Update complete, please remove the USB stick

The monitor needs to be rebooted to complete the upgrade. Once the drive has been removed, a screen prompts the user to shut down. Press Shutdown to power off the monitor.

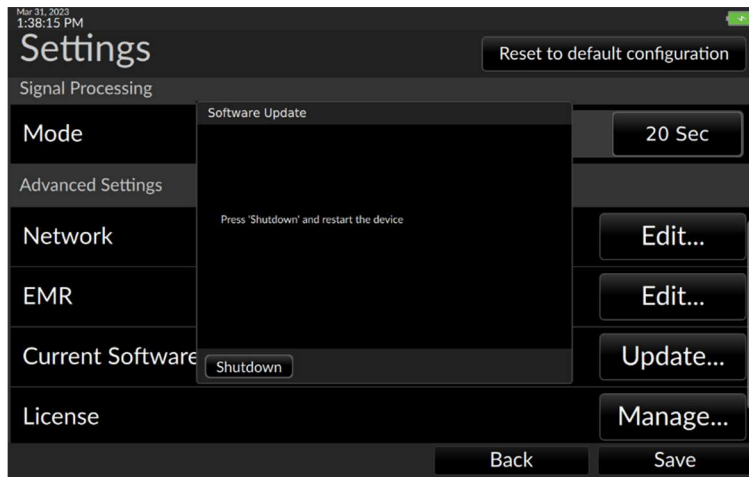

Fig. 4-31: Press Shutdown to reboot the device

The monitor will power off. Wait for the power indicator to turn off, then press and hold the power button for five seconds following shutdown to restart the monitor with the new software installed.

Upon reboot, to verify the upgrade, press the User Menu icon and select About:

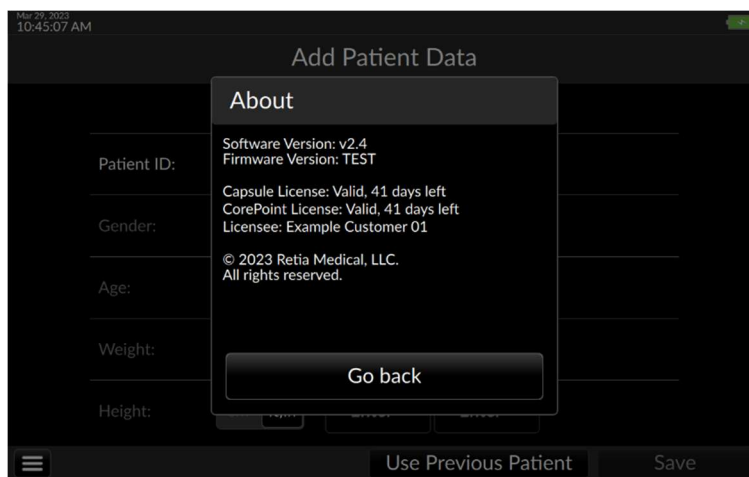

Fig. 4-32: About page showing the upgraded version

If when an upgrade is attempted and there is no USB stick in the slot, more than one USB drive is inserted, or the drive does not contain the upgrade, an error message appears.

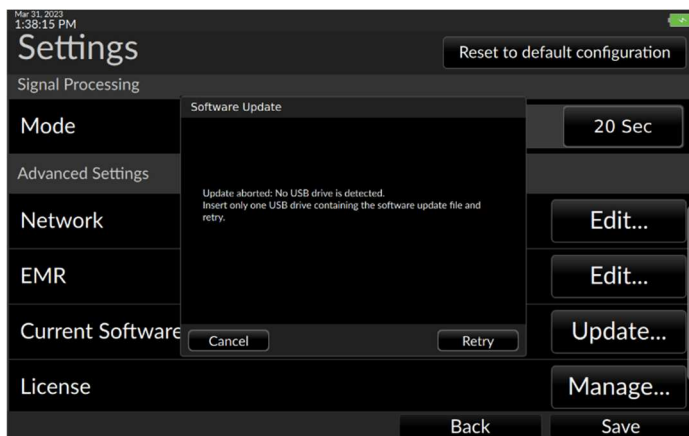

Fig. 4-33: No USB drive detected

If multiple USB drives are inserted the software update will not function.

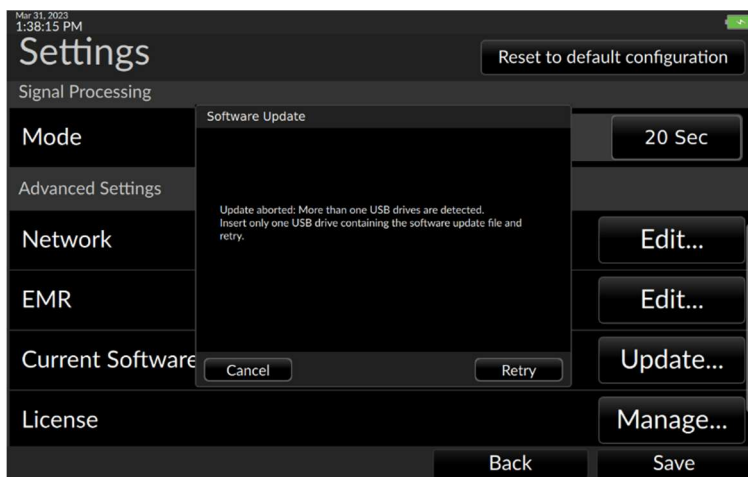

Fig. 4-34: More than one USB drive detected

If no upgrade file is found, the Argos will report an error and the user will be prompted to try again.

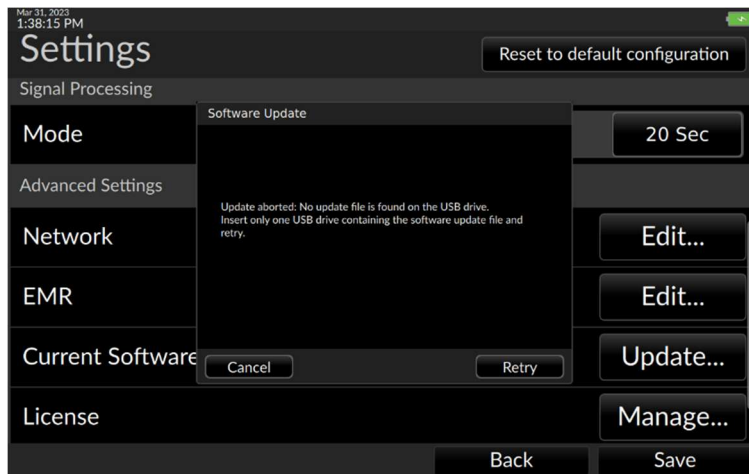

Fig. 4-35: No update file found

Correct the error and retry the upgrade.

5 Help

The following is a list of error messages and recommended actions:

Message	Possible cause(s)	Suggested action
Check Arterial BP waveform	<p>Arterial BP waveform signal quality is insufficient to calculate CO</p> <p>Noisy BP signal due to patient/cable movement</p> <p>Electromagnetic interference from high frequency electrosurgical equipment or other sources</p> <p>Very low pulse pressure, Systolic Pressure too high or Diastolic pressure too low</p> <p>Non-physiological BP signal due to occluded/disconnected transducer tubing</p>	<p>Check the arterial BP waveform for sources of noise, from patient to the Argos monitor</p> <p>Check the arterial waveform for physiological causes of artifact such as severe hypotension, severe hypertension, or motion artifact.</p> <p>Inspect all arterial pressure lines. Ensure stopcocks are properly positioned.</p> <p>Inspect the arterial catheter. Ensure it is not blocked or kinked.</p> <p>Make sure the transducer is aligned with the patient's phlebostatic axis.</p> <p>Re-zero the transducer.</p>
Check cable connection	<p>Transducer cable is disconnected</p> <p>External monitor cable is disconnected</p>	<p>Check cable connection to the transducer</p> <p>Check cable to the external monitor</p>
Low Battery	Argos Monitor is operating on internal battery power and the battery level is below 25%	Plug in the Argos monitor to the AC mains. If the battery no longer holds a charge after connecting to a working mains, it needs to be replaced. Contact Retia Medical Technical Support.
Internal Error	Internal System malfunction	Power off system and restart the monitor. If problems persists, contact Retia Medical Technical Support.
Verification failed	<p>Cannot connect to server</p> <p>Server communication error</p> <p>No record found</p> <p>More than one record found</p>	<p>Verify Patient ID</p> <p>Verify device network settings</p> <p>Verify network is up</p> <p>Correct server Patient ID</p>

Table 7: Troubleshooting error messages

Notes:

1. If the software freezes and the device becomes unresponsive, press the power button for at least 30 seconds to initiate a forced shutdown.
2. Because the Argos monitor is not used as a stand-alone patient monitor, all alerts, including CO and derived hemodynamic monitoring parameters, are low priority.



WARNING

A hazard can exist if different alarm/alert presets are used for the same or similar equipment in any single area.

3. When a monitored parameter exceeds an upper or lower alert limit, a yellow box will highlight the displayed limit. Please see section 2.1, page 24 for more details. Alerts are fully visible to a user operating the Argos monitor facing the screen.
5. If the Argos monitor detects artifacts or noise in the BP signal for any reason, in addition to displaying an error message on the status section of the status bar as listed above, the monitor will not display numeric trend values:

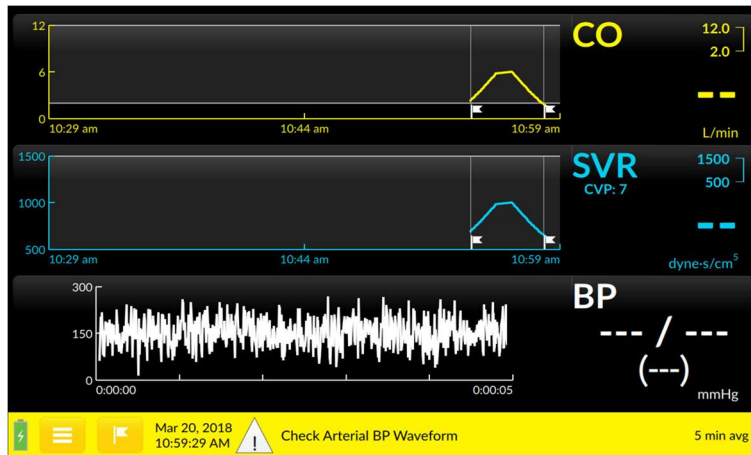

Fig. 5-1: Error message displayed, with null trend values

- ▶ *After correction of the condition which led to the error, while the error message may disappear, allow at least 25 seconds for the sample size to produce accurate results.*

If any of the indicated solutions does not work, or the user is experiencing any other problems or issues with the Argos monitor, contact Retia Medical technical support by phone at (+1) 914 437 6704 or email at info@retiamedical.com.

Specifications

The Argos Cardiac Output Monitor measures cardiac output (CO) and derived hemodynamic parameter when used with an appropriate radial or femoral artery sensing device.

Appendix A includes summaries of the following: Physical and Mechanical Specifications

- Electrical Specifications
- Environmental Specifications:
 - Operating Conditions
 - Transport and Storage Conditions
- Displayed Parameters
- Standards Compliance
- Monitor and Accessories part numbers

Table 8: Physical and Mechanical Specifications

Attribute	Value	
Weight	8.3 lb. / 3.76 kg	
Dimensions	Height	10.6" / 269.5 mm
	Width	12.36" / 314 mm
	Depth	3.86" / 98 mm
Display	Type	10.1" Color TFT LCD, touch screen
	Viewing area	8.54" × 5.34" / 216.96mm × 135.6mm
	Resolution	1280 × 800
User interface	Touch screen	
Data Capacity	1200 hours	
Data Export	FAT32-formatted, USB 2.0-compatible, removable drive.	

Table 9: Electrical Specifications

Attribute	Value
Mains Voltage	100 to 240 V, AC
Mains Frequency	50/60 Hz
Power Consumption	36 W
Bedside patient monitor input	1 V/100 mmHg

Table 10: Environmental Specifications

Property	Value
Operating conditions	
Temperature range	5 to 35 °C
Relative Humidity	10 to 95 %
Ambient Pressure	70 to 106 kPa
Transport and Storage Conditions	
Temperature range	-25 to 70 °C
Relative Humidity	10 to 100 %
Ambient Pressure	50 to 106 kPa

Table 11: Parameters

Parameter	Specification	
CO	Reproducibility	0.1 l/minute
	Update Rate	5 seconds

Table 12: Standards Compliance

Applied Part Type	1x Type CF defibrillation-proof
Equipment class	Class II
Electrical Protection Class	IEC Class I
Ingress Protection Class	IPX1
IEC Standards	IEC 60601-1:2005+AMD1:2012
	IEC 60601-1-2:2014
	IEC 60601-2-34:2011*
	IEC 60601-1-8: 2011 IEC 62366-1:2015
Packaging standard	ISTA 2A

*Not including the section (208.6) on alarms. All alarms are governed by IEC 60601-1-8.

Table 13 Argos Cardiac Output Monitor and Accessory Part Numbers

Item/Category	Part number
Argos Cardiac Output monitor	FG-001
Bedside patient monitor interface cables	
Interface cable for Philips Monitors	FG-002
Interface cable for GE PDM Monitors	FG-003
Interface cable for GE Solar Monitors (with TRAM RAC 4A)	FG-005
Interface cable for Draeger Monitors	FG-006
Interface cable for Spacelabs Xprezzon Monitors	FG-007
Interface cable for Mindray BeneVision N series Monitors	FG-011
Interface cable for Nihon Kohden Monitors	FG-012
Parts and Accessories	
LAN Connectivity Kit	FG-008
Serial Connectivity Kit	FG-009
Replacement Power Supply and AC cord	FG-010
Utah Medical BP Transducer Kit (pack of 25): includes BP Transducer, Y connector, tubing	902-649
Utah Medical Transducer Interface Cable	FG-015
Custom adjustable pole mount roll stand	IMS-003BR2
Table/pedestal stand	30-036
Adjustable Rail Clamps	FLP-0008-17
Operator's Manual	60-001
Quick Start Guide	60-025
Retia Service Manual	60-026

To order parts or accessories please contact Retia customer support or your Retia representative.

**WARNING**

The Argos monitor should not be used to monitor arterial blood pressure. The arterial blood pressure transducer input on the Argos monitor is to be used only when another arterial blood pressure transducer is connected in parallel to a bedside patient monitor with the appropriate blood pressure alarms.

**WARNING**

Before connecting a bedside patient monitor to the Argos monitor, consult with the Retia Medical representative to ensure the bedside patient monitor has the correct specifications.

**WARNING**

Only connect accessories that have been qualified as part of the Argos monitor.

Equations for Calculated Patient Parameters

Table 14: Hemodynamic Parameters			
Parameter		Formula	Units
Cardiac Output	CO	Proprietary MBA algorithm	L/min
Cardiac Index	CI	Cardiac Index $CI = CO/BSA$ where: CI - Cardiac Index, CO - Cardiac Output, L/min BSA - Body Surface Area, m ²	L/min/m ²
Mean Arterial Pressure	MAP	Average systemic arterial blood pressure.	mmHg
Heart rate	HR	Number of heartbeats per minute.	Bpm (beats/min)
Blood pressure	BP	The pressure of blood in the circulatory system.	mmHg
Stroke Volume	SV	Stroke Volume $SV = (CO/HR) \times 1000$ where: CO - Cardiac Output, L/min HR - Heart rate, beats/min	mL
Stroke Volume Index	SVI	Stroke Volume Index $SVI = (CI/PR) \times 1000$ where CI - Cardiac Index, L/min/m ² HR - Heart rate, beats/min	mL/m ²
Systemic Vascular Resistance	SVR	Systemic Vascular Resistance $SVR = [(MAP - CVP) \times 80] / CO$ (dyne-sec/cm ⁵) where: MAP - Mean Arterial Pressure, mmHg CVP - Central Venous Pressure, mmHg CO - Cardiac Output, L/min	dyne-s/cm ⁵
Systemic Vascular Resistance Index	SVRI	Systemic Vascular Resistance Index $SVRI = [(MAP - CVP) \times 80] / CI$ where: MAP - Mean Arterial Pressure, mmHg CVP - Central Venous Pressure, mmHg CI - Cardiac Index, L/min/m ²	dyne-s-m ² /cm ⁵
Pulse Pressure Variation	PPV	The difference between maximum and minimum pulse pressure over a respiratory cycle, per mean pulse pressure	%

Table 15: Technical Details for Dynamic Assessment	
Filtering equation	The dynamic assessment module filters all incoming data through a 3 sample median filter. One invalid input sample makes the result of the filter invalid. $\text{median}(x_i, x_{i-1}, x_{i-2})$
Instability equation	A baseline is considered unstable if its Coefficient of Variation is greater than or equal to 5%. $CV = \frac{s}{\bar{x}}$
Percent Change	If b is the value of the baseline, percent change is calculated as follows: $\frac{x_i - b}{b} \cdot 100\%$
Challenge Validity	A challenge is considered valid if there is one filtered sample above 10% or if greater than two thirds of the samples in the challenge are valid.

For further information please visit Retia.ai or contact us by email or phone.

Default Settings

Table 16: Argos Monitor Defaults

Parameter	Min Graph Default	Max Graph Default	Graph Setting increment	Low Alarm Default	High Alarm Default	Alarm Setting Increment	Color
CO	2	10	1	4	8	0.1	Yellow
CI	1	5	1	2.5	4	0.1	Yellow
SV	20	120	20	60	100	5	Light Blue
SVI	10	60	20	30	50	5	Light Blue
SVR	500	2000	100	800	1200	50	Purple
SVRI	1000	4000	200	2000	2400	50	Purple
MAP	50	120	20	65	100	5	Red
HR	40	140	20	60	100	5	Green
PPV	0	20	10	0	13	1	Gray
BP	50	150	10	NA	NA	NA	Red

- For SVR and SVRI, default CVP is 7 mmHg
- Monitoring Mode Default: 20 seconds
- Date Format Default: MM/DD/YY
- Time Format: 12-hour Time (HH: MM AM/PM)
- "Show SVI" and other indexed parameters are selected
- Time Scale Default: 10 minutes
- Default event flag for "Start Session"
- Default parameters on Trend Screen: Stroke Volume (SV), Systemic Vascular Resistance (SVR), and Blood Pressure (BP)

Unit Conversions

5.4.1 Lbs to/from kg

Conversion factors: lb → kg: $lb \div 2.2$
kg → lb: $kg \times 2.2$

5.4.2 inches to/from cm

Conversion factors: inches → cm: $inches \times 2.54$
cm → inches: $cm \div 2.54$

5.5 Care, Service, and Support

Only clean the Argos monitor as directed in this appendix.

No other scheduled maintenance or routine service is required: the Argos monitor contains no user-serviceable parts, and should only be repaired by a service representative authorized by Retia.

Information on contacting a Retia Medical representative for support, repair, or replacement may be found at the end of this appendix.



WARNING

The Argos monitor contains no user-serviceable parts. Removing the cover or any other disassembly will expose the user to hazardous voltages.



WARNING

Shock or fire hazard! Do not immerse the Argos monitor or cables in any liquid solution. Do not allow any fluids to enter the device.

5.6 Cleaning the Monitor



CAUTION

Do not pour or spray liquid onto the monitor or accessories.

To clean the surface of the Argos Monitor, dampen a clean cloth with disinfectant, either 70% isopropyl alcohol solution

- diluted bleach solution (1 part bleach to 10 parts water)
- a non-abrasive liquid commercial cleaner

Lightly wipe the surface of the Argos monitor.

5.7 Monitor Maintenance

Periodically inspect the monitor for signs of wear. Check to make sure the monitor body is intact and not broken or cracked, and shows no sign of abuse or tampering.

5.8 Cable Maintenance



CAUTION

Do not immerse cable connectors in detergent, isopropyl alcohol or glutaraldehyde.



CAUTION

NEVER:

- Allow any liquid to come in contact with the power cable.
- Allow any liquid to penetrate connectors or openings in the case

Should liquid contact the power cable or penetrate the case, do not attempt to operate the monitor. Instead, shut down the monitor, disconnect power immediately, and call the Biomedical Department or Retia Medical representative.



CAUTION

Do not use any heating device to dry cable connectors.



CAUTION

Regularly inspect all cables for defects. Never coil cables tightly while using, or when storing.



CAUTION

If any electrolytic solution such as NaCl, Lactated Ringers, is allowed to contact the cable connectors while connected to the Argos monitor, and the monitor is turned on, the excitation voltage may cause electrolytic corrosion and rapid degradation of the electrical contacts. Therefore, do not allow electrolytic solutions to contact the cable connectors.

Periodically inspect cables and lines for signs of wear or age. Discontinue use immediately if the user finds fraying cable, cracked or broken insulation, or faulty (broken pins, cracking housing) connectors, or exposed electrical or mechanical contacts.

From time to time, or as needed, wipe the patient cable with a clean cloth using 10% bleach and 90% water. Allow the cable to air dry.

Data Port Maintenance

The port on the side of monitor is meant for data export only and is locked for any other purpose. The Argos monitor does not have any capability for network connection. Do not use USB drives containing any executable.

If the user needs further assistance, please contact Retia Medical.

5.10 When Monitor Service is Required

Care should be taken to ensure the monitor's continued safe operation: therefore, periodically inspect the device to ensure it is fully functional. Discontinue use immediately if:

- Cables are frayed
- Screen or enclosure cracked or show signs of functional wear
- Labels torn or tampered with
- Connectors loose or broken
- Monitor shows evidence of overheating

Service and Support

See **§5 Help** for diagnosis and remedies. If the user still cannot solve the problem, please contact Retia Medical by phone at (+1) 914 437 6704 or email at info@retiamedical.com

When calling, please have at hand:

- The monitor's serial number, printed on the rear panel;
- The text of the error message(s), if any, and detailed information as to the nature of the problem.

5.12 Alert Functionality Verification

To confirm alert capability, follow this procedure: Note the current value for SV.

1. Press the SV trend label to change the upper alert limit, as described in §2.8.5, page 49, to a value lower than the current SV value, and press Save.
2. Verify that in the SV numeric area, the upper alert limit is highlighted with a yellow box.
3. Press the SV trend label to change the lower alert limit to a value higher than the current SV value, and press Save.
4. Verify that in the SV numeric area, the upper alert limit is highlighted with a yellow box.
5. Adjust the alert limits for future patient monitoring.
6. Disconnect the external monitor cable.
7. Verify that the status bar turns yellow and displays the message "Check cable connection".
8. Connect the external monitor cable back into the Argos monitor.



WARNING

Ensure that after alert verification, the alert limits are adjusted to physiologically appropriate values for patient monitoring.

6 Clinical Studies

6.1 Chapter Overview

This chapter provides information on the clinical validation study using the Argos Hemodynamic Monitor. A Reference Bibliography containing additional clinical studies is available on Retia's website (Retia.ai) or by contacting a Retia Medical Customer Service representative.

An adult study was performed on critically ill patients in the operating room and intensive care unit comparing the accuracy of the cardiac output (CO) measurements from the Argos Monitor to the accuracy of CO measurements from the predicate device (Edwards Lifesciences' Vigileo Cardiac Output Monitor version 3). The accuracy of both devices was determined with respect to reference cardiac output readings obtained via the thermodilution method, from a pulmonary artery (PA) catheter. The study was performed on 40 patients under informed consent as part of a protocol approved by the IRB for Columbia University Medical Center (Predicate Comparison Study). No adverse events attributable to the Argos Monitor were reported during the study.

The Predicate Comparison Study evaluated the accuracy of the CO values as reported by the Argos Monitor compared to the reference CO values obtained via a pulmonary artery catheter. For the reference CO, both bolus thermodilution and continuous PA catheter measurements were used. Accuracy of the predicate device CO measurements was evaluated similarly, with respect to the same CO reference. Finally, the absolute and trend accuracy of the Argos monitor was compared with the predicate device. Both the Argos and predicate device calculated CO via analysis of the same blood pressure waveform from a radial or femoral arterial catheter.

The 40 patients included: 20 operating room (OR) patients (liver transplant and cardiac surgeries) and 20 intensive care unit (ICU) patients (post-liver transplant and post-cardiac surgery); 28 males and 12 females; age 20 to 83 years, with a mean of 62 years. Out of a total of 236 possible data points, 32 were removed due to missing signal (BP or reference CO) and 15 were removed due to signal artifact or hemodynamic instability in accordance with the data selection criteria, leaving 189 time points available for analysis.

Methods: Reference cardiac output measurements from the PA catheter (including the reference time points) were recorded along with Blood pressure signals, which were simultaneously fed to the Argos and the predicate monitors. For the OR patients, reference measurements were made according to pre-defined surgical landmarks. In the case of liver transplants, these were: incision, pre-clamping of the vena cava, post-clamping, post-unclamping, and closure. In the case of cardiac surgeries, these were: incision, pre-bypass, post-bypass, and closure. In the case of ICU patients, the time points were every 2 hours when reference measurements were available.

6.1.1 Results

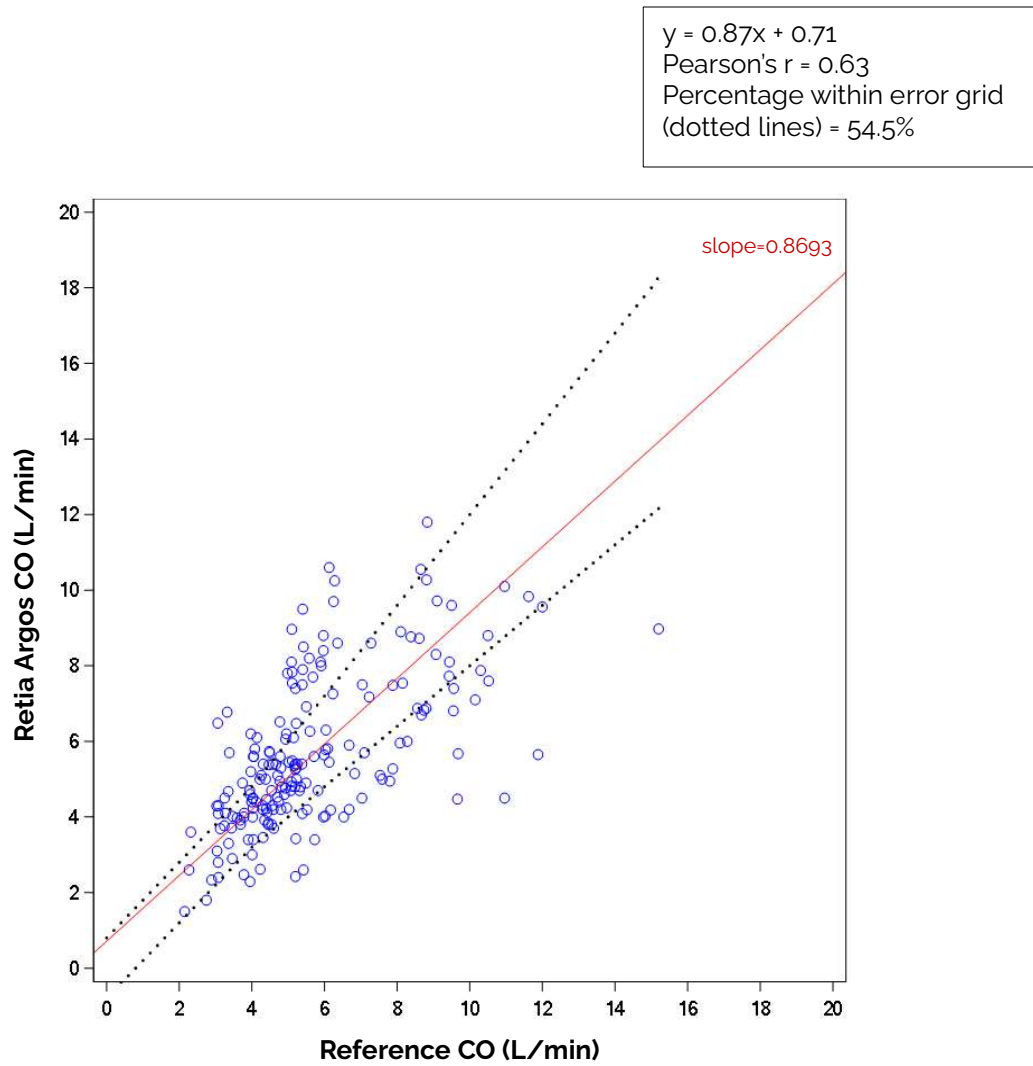

Fig. 6-1: Regression (unweighted Deming) plot for Retia Argos CO versus reference CO for all patients

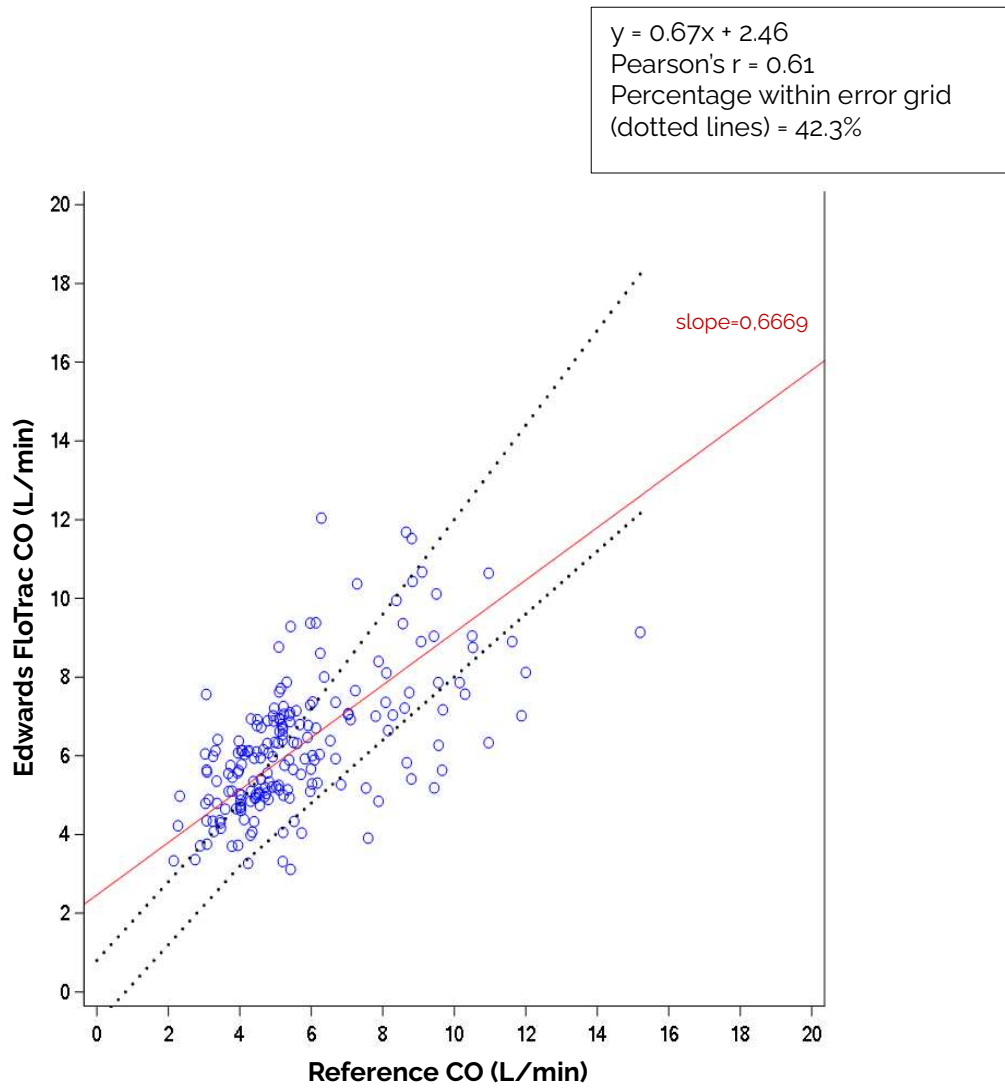

Fig. 6-2: Regression (unweighted Deming) plot for predicate CO versus reference CO for all patients

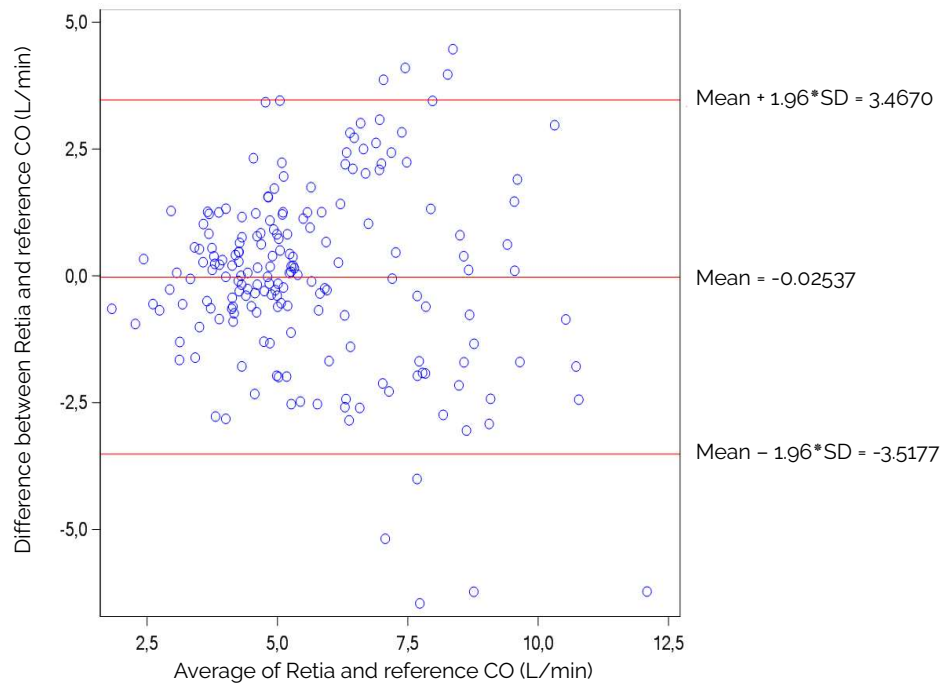

Fig. 6-3: Bland-Altman plot comparing Retia Argos CO to reference CO for all patients. LOA [-3.52 to 3.47]

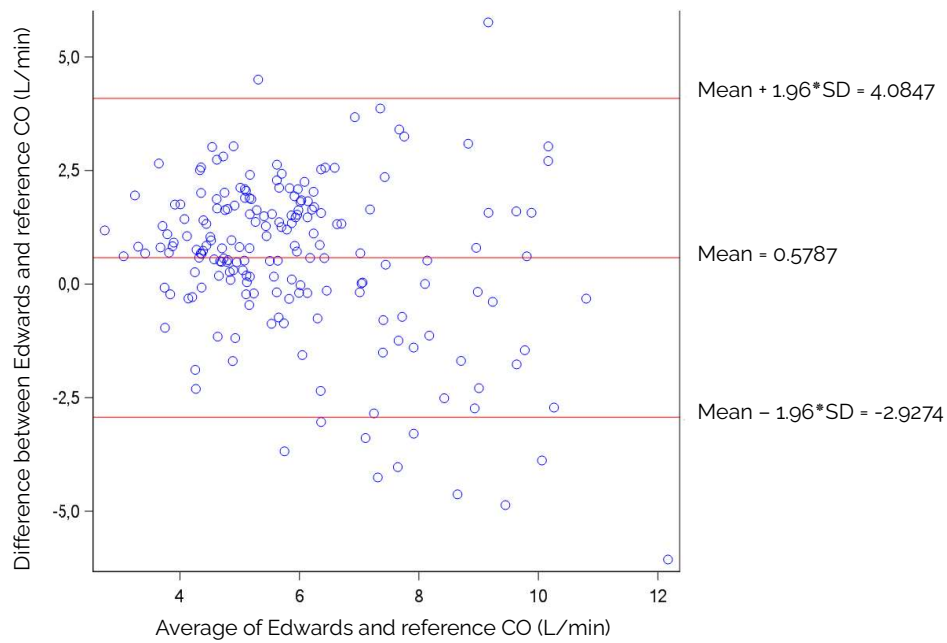

Fig. 6-4: Bland-Altman plot comparing predicate CO to reference CO for all patients. LOA [-2.93 to 4.08]

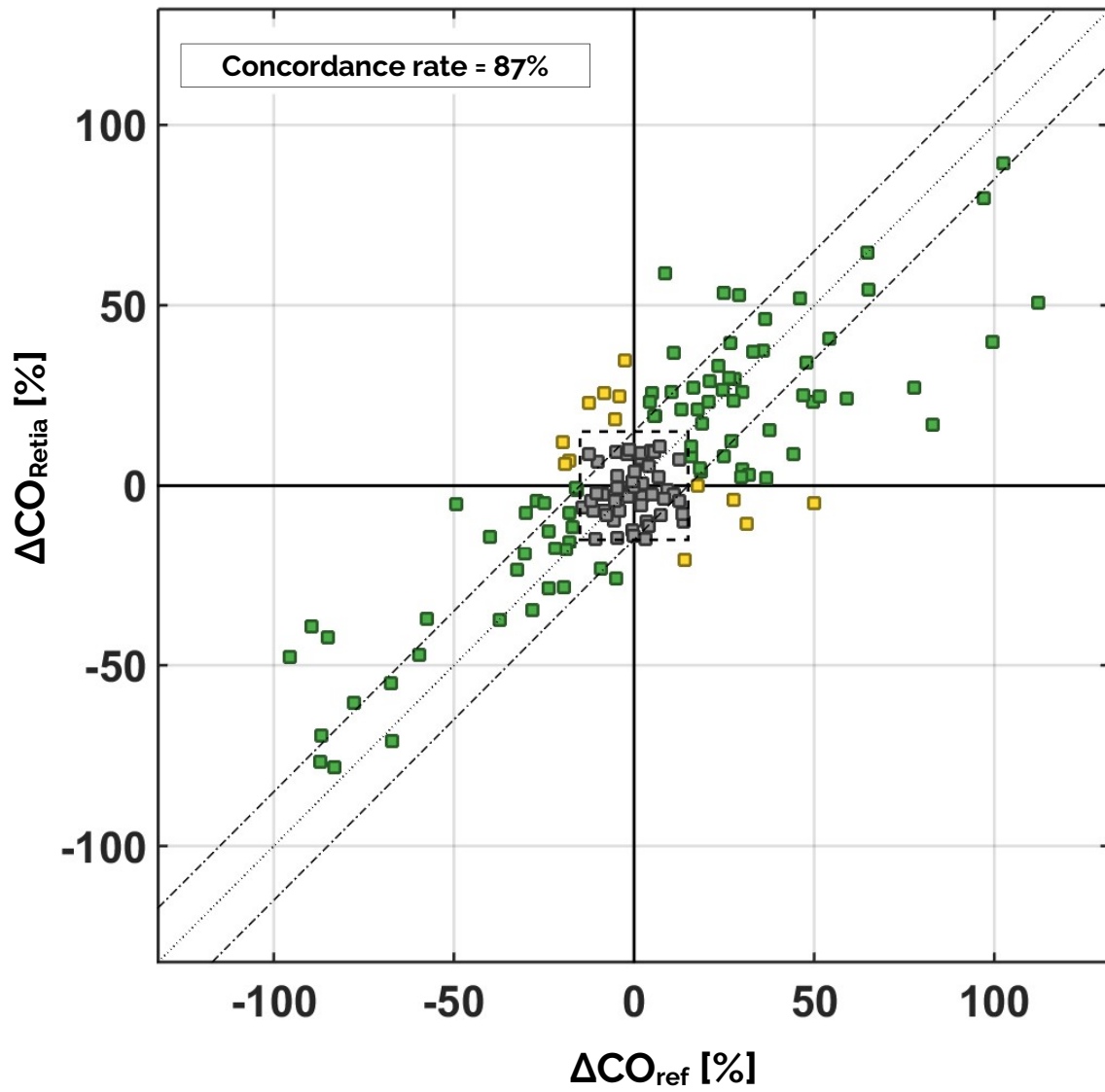

Fig. 6-5: Concordance plot for percentage changes in Retia Argos CO versus percentage changes in reference CO

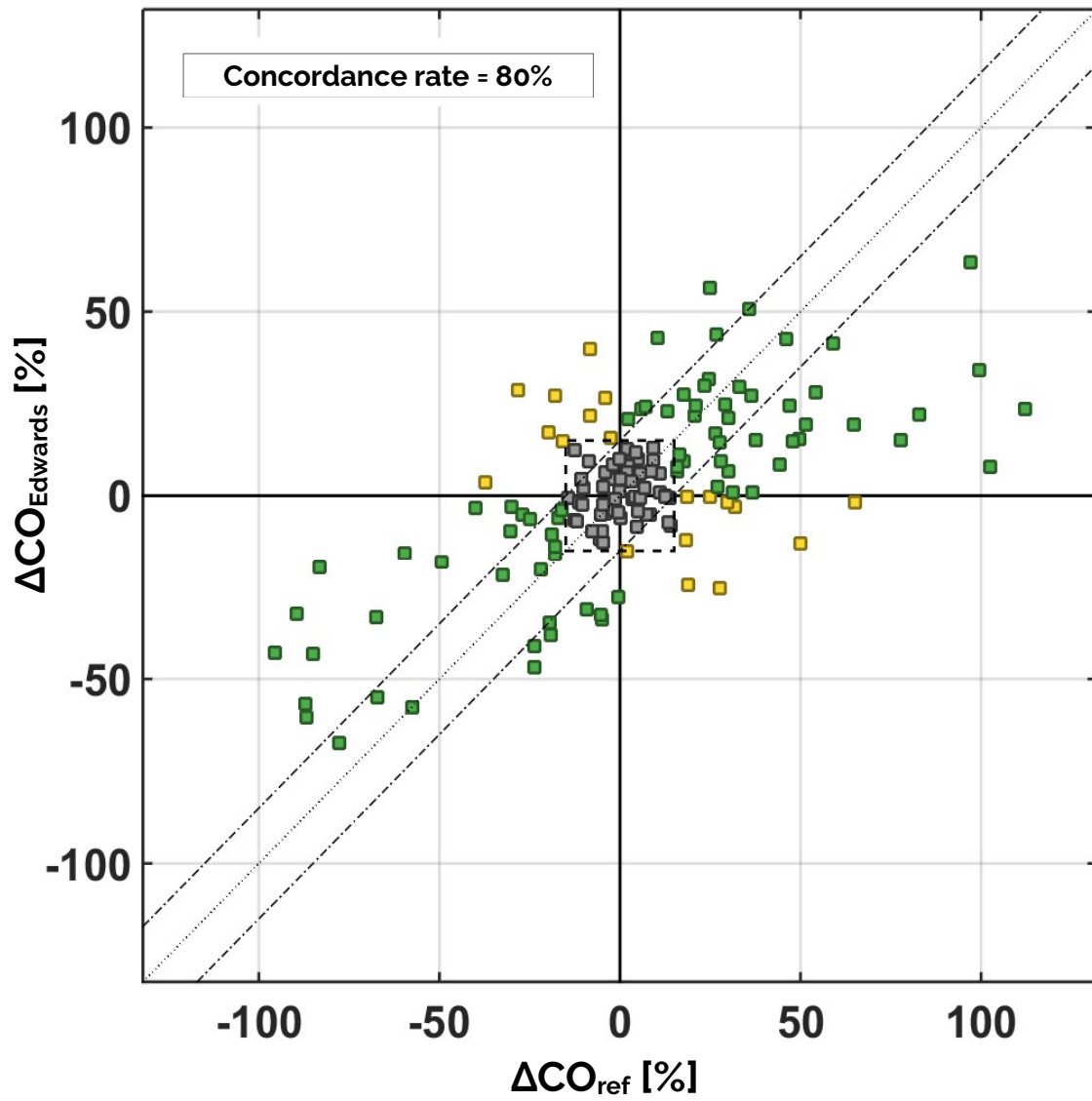

Fig. 6-6: Concordance plot for percentage changes in predicate CO versus percentage changes in reference CO

Analysis subgroup	Performance metric with respect to CO-Thermodilution	Retia-Argos [95% CI]	Predicate device [95% CI]
Overall CO	Bias	-0.03 L/min [-0.53 to 0.47]	0.58 L/min [-0.12 to 1.04]
	Precision	1.78 L/min [1.52 to 2.15]	1.79 L/min [1.56 to 2.10]
	NRMSE	31.5%	33.2%
	Concordance Rate	87% [81.3 to 91.9]	80% [74.2 to 86.2]
CO ≥ 5 L/min	RMSE	2.09 L/min	2.05 L/min
CO < 5 L/min	RMSE	1.19 L/min	1.62 L/min

Table 17: Summary statistics including bias, precision, normalized root mean squared error (NRMSE), concordance and root mean squared error for sub-group analyses.

The NRMSE represents the average size of error in percentage of a device. Specifically defined as follows:

$$NRMSE = 100 \cdot \frac{\sqrt{\mu^2 + \sigma^2}}{E(X)}$$

where μ is the bias, σ is the precision, and $E(X)$ is the expected value (or average) of the reference CO.

The RMSE is computed as follows:

$$RMSE = 100 \cdot \sqrt{\mu^2 + \sigma^2}$$

Concordance was calculated using a 15% exclusion zone as recommended in Critchley, L. A., Lee, A. & Ho, A. M. H. A critical review of the ability of continuous cardiac output monitors to measure trends in cardiac output. *Anesth. Ana.* 111, 1180–1192 (2010). Percentage within the error grid was calculated according to Forrest, S.W. et al. Statistical Comparison of Cardiac Output Measurement Methods: Advantages of an Error Grid Representation. *Journal of Cardiac Failure*, Volume 14, Issue 6, S56.

Validation with femoral BP

To validate the Argos monitor's performance when using femoral BP signal as the input, a study similar to the one described above was performed. The purpose of the study was to evaluate the accuracy of the Argos monitor and Edwards Lifesciences' Vigileo Cardiac Output Monitor version 3, with the reference CO measured via the continuous thermodilution method, from a pulmonary artery catheter (PAC). The study was performed with data from 22 adult patients undergoing liver transplant surgery, collected under informed consent as part of a protocol approved by the IRB for Columbia University Medical Center.

Analysis methods follow the Predicate Comparison study above. CO estimates from the Argos and the Edwards devices were obtained by simultaneously feeding the femoral BP waveforms to both devices. These estimates were then compared to the reference CO at the following surgical landmarks: incision; pre-clamping of the vena cava; post-clamp; post-unclamp; and closure.

The 22 patients included 13 Males and 9 females; age 19 – 69 years (mean age 54 years). In one of the subjects, 2 measurements were excluded due to instability of the reference CO, in accordance with the data selection criteria, leaving a total of 108 measurements available for analysis. For the concordance analysis, percent change between consecutive segments was used for each method (reference, Argos and Edwards Vigileo). A total of 86 changes were available for the concordance analysis. Figures 9-7 through 9-11 show the Regression, Bland-Altman, and Concordance plots for the Argos and the Vigileo device, with thermodilution as the reference. Results are shown in Table 18 below.

Analysis subgroup	Performance metric with respect to CO-Thermodilution	Retia-Argos [95% CI]	Predicate device [95% CI]
Overall CO	Bias	0.75 L/min [-0.09 to 1.58]	0.23 L/min [-0.60 to 1.06]
	Precision	2.13 L/min [1.73 to 2.78]	2.30 L/min [1.89 to 2.93]
	NRMSE	33.7%	34.4%
	Concordance Rate	94%	87%
CO < 5 L/min	Bias	0.98 L/min [0.43 to 1.52]	1.53 L/min [0.84 to 2.22]
	Precision	1.15 L/min [0.91 to 1.59]	1.46 L/min [1.14 to 2.03]
	NRMSE	38.3%	34.4%
CO ≥ 5 L/min	Bias	0.67 L/min [-0.26 to 1.59]	-0.25 L/min [-1.11 to 0.62]
	Precision	2.31 L/min [1.87 to 3.03]	2.29 L/min [1.88 to 2.92]
	NRMSE	31.1%	29.8%

Table 18: Summary statistics including bias, precision, NRMSE and concordance for all data and subgroups. Note that concordance is not calculated for the subgroups due to restricted data.

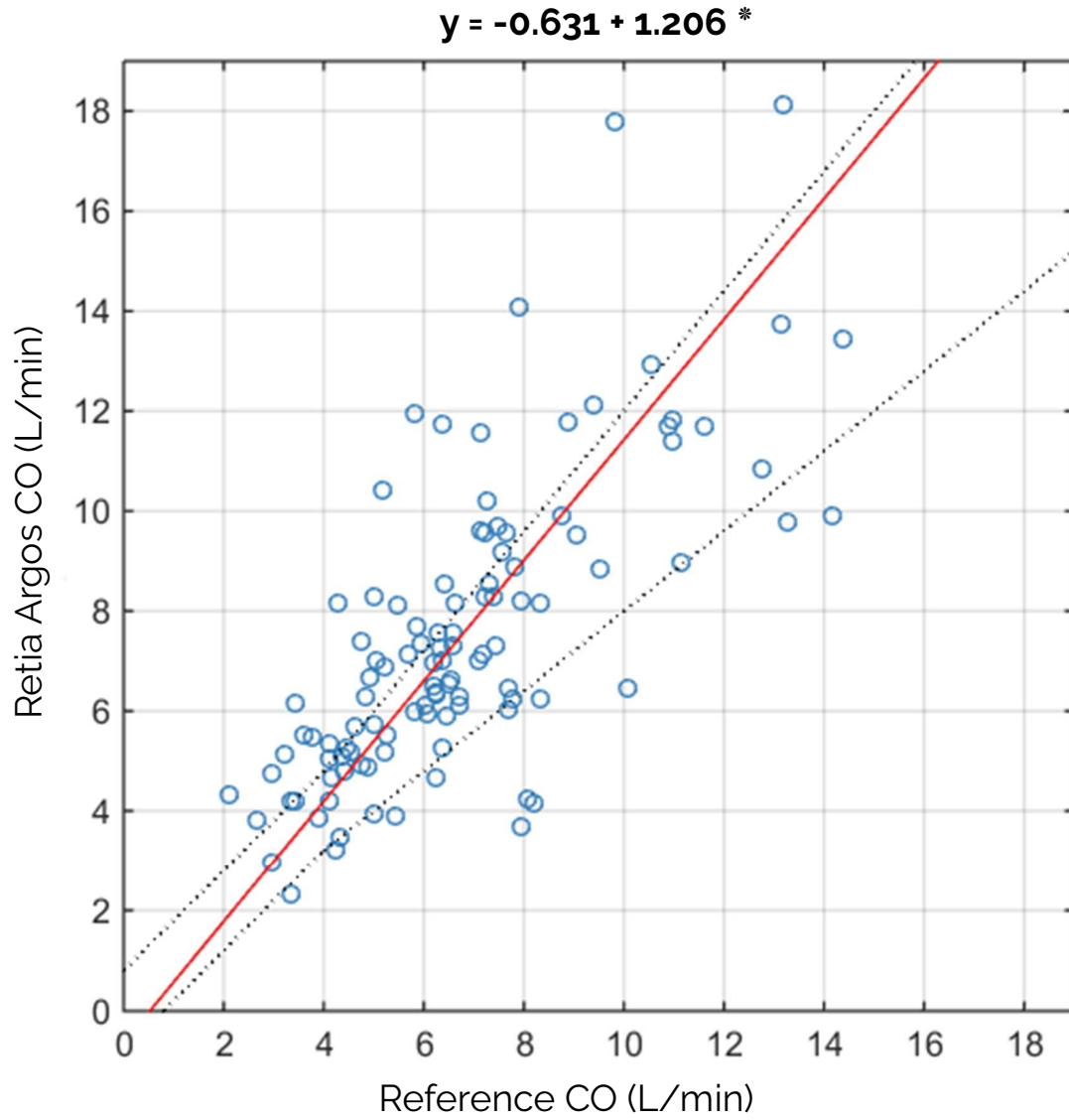

$$y = 1.849 + 0.759 * x$$

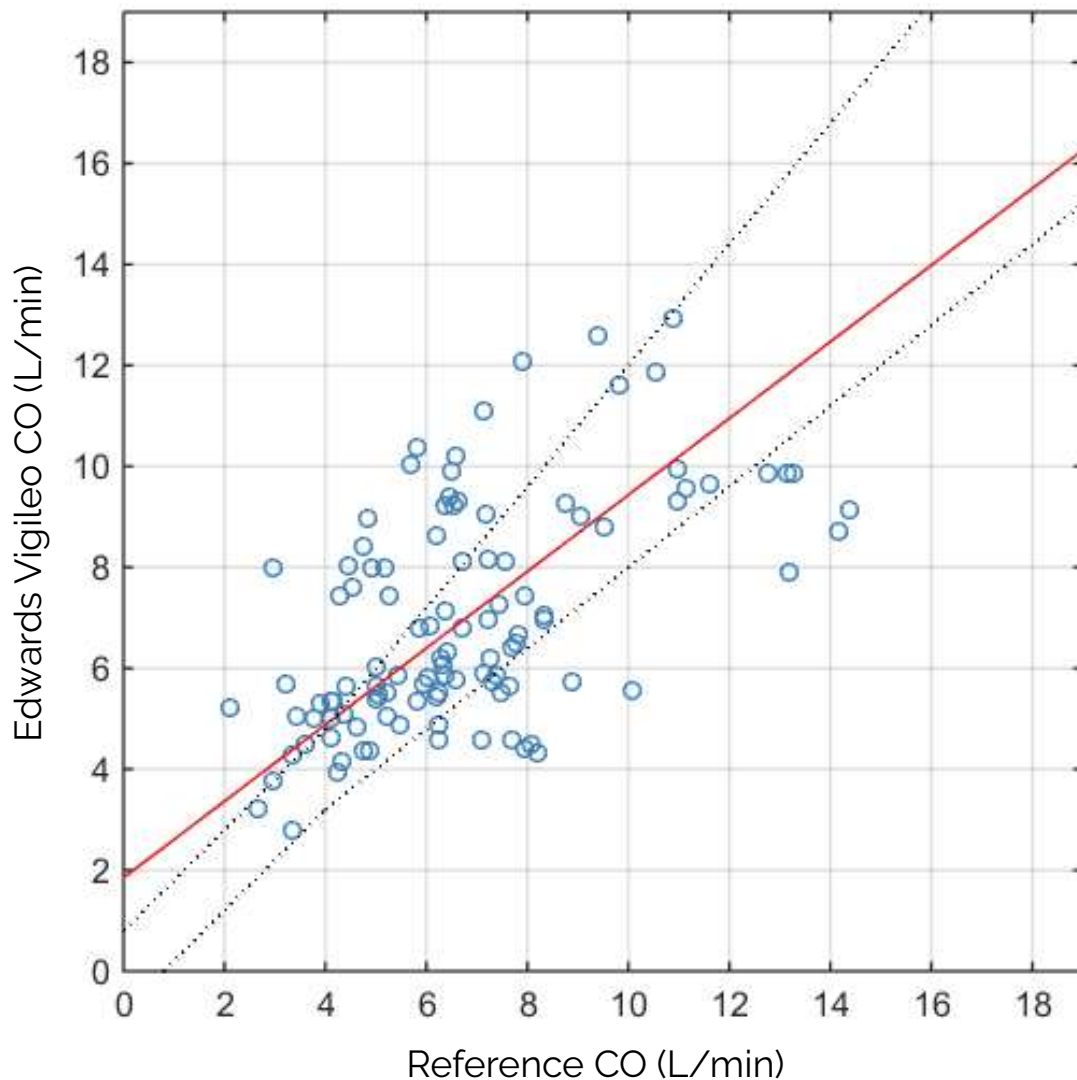

Fig. 6-7: Regression (unweighted Deming) plots for Vigileo CO versus reference CO. Pearson's r = 0.57; Percentage within error grid = 49%

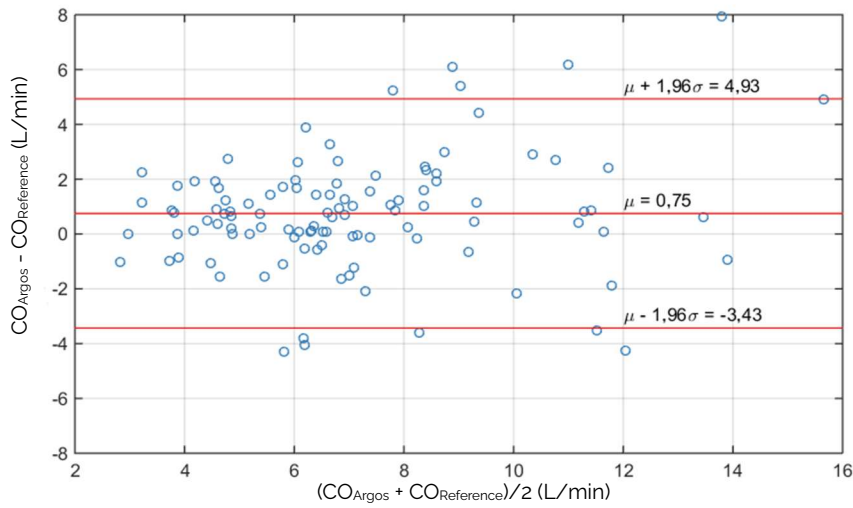

Fig. 6-8: Bland-Altman plot comparing Argos CO to reference CO. LOA [-3.43 to 4.93]

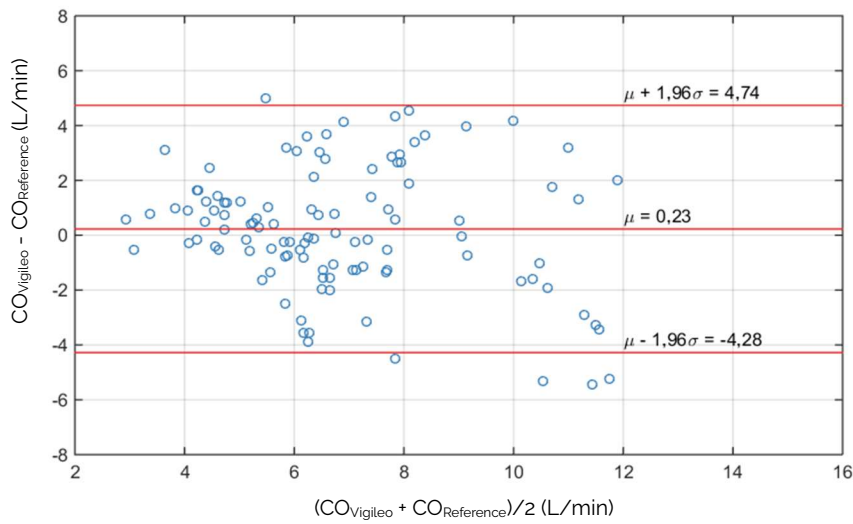

Fig. 6-9: Bland-Altman plot comparing Vigileo CO to reference CO. LOA [-4.28 to 4.74]

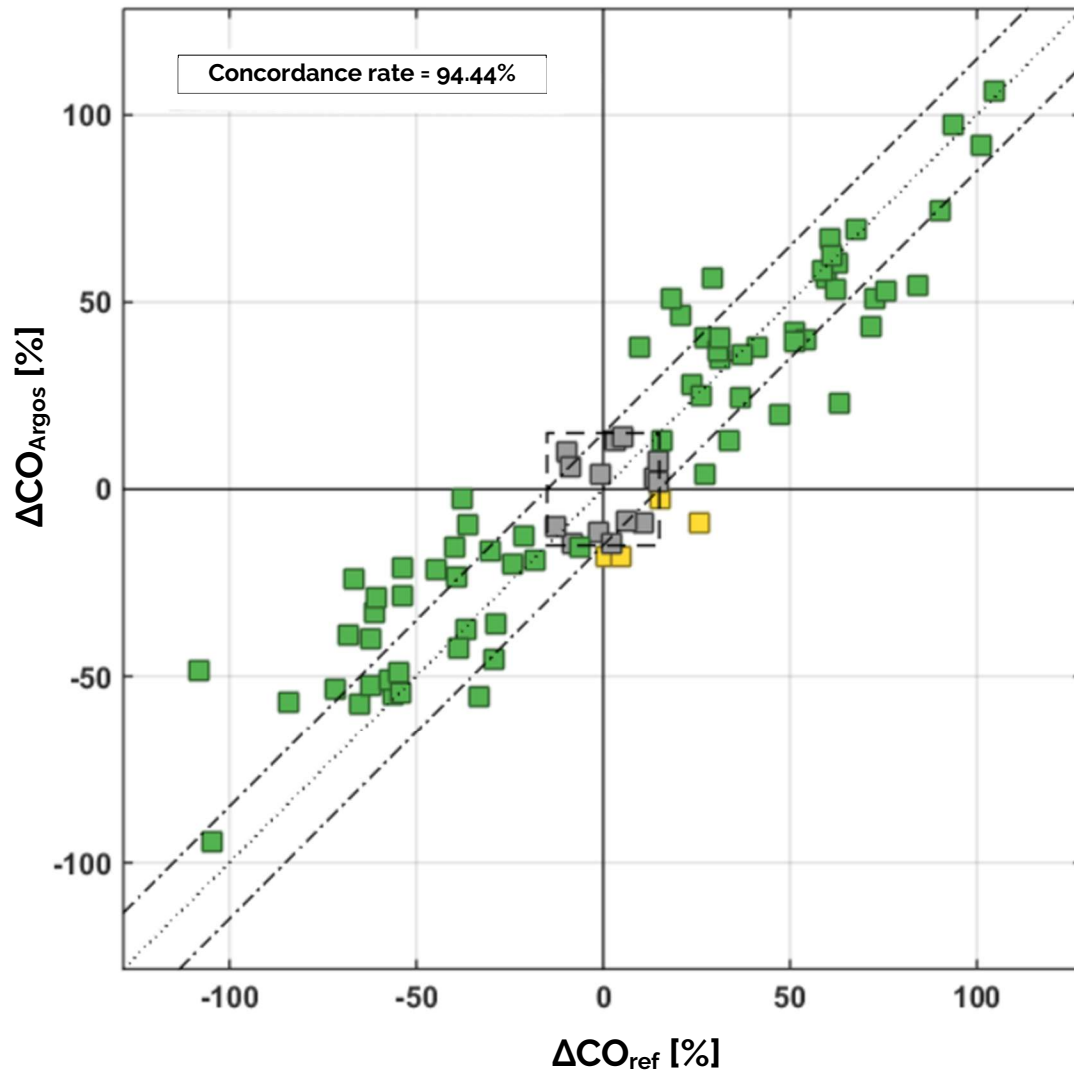

Fig. 6-10: Concordance plot for percentage changes in Argos CO versus percentage changes in reference CO

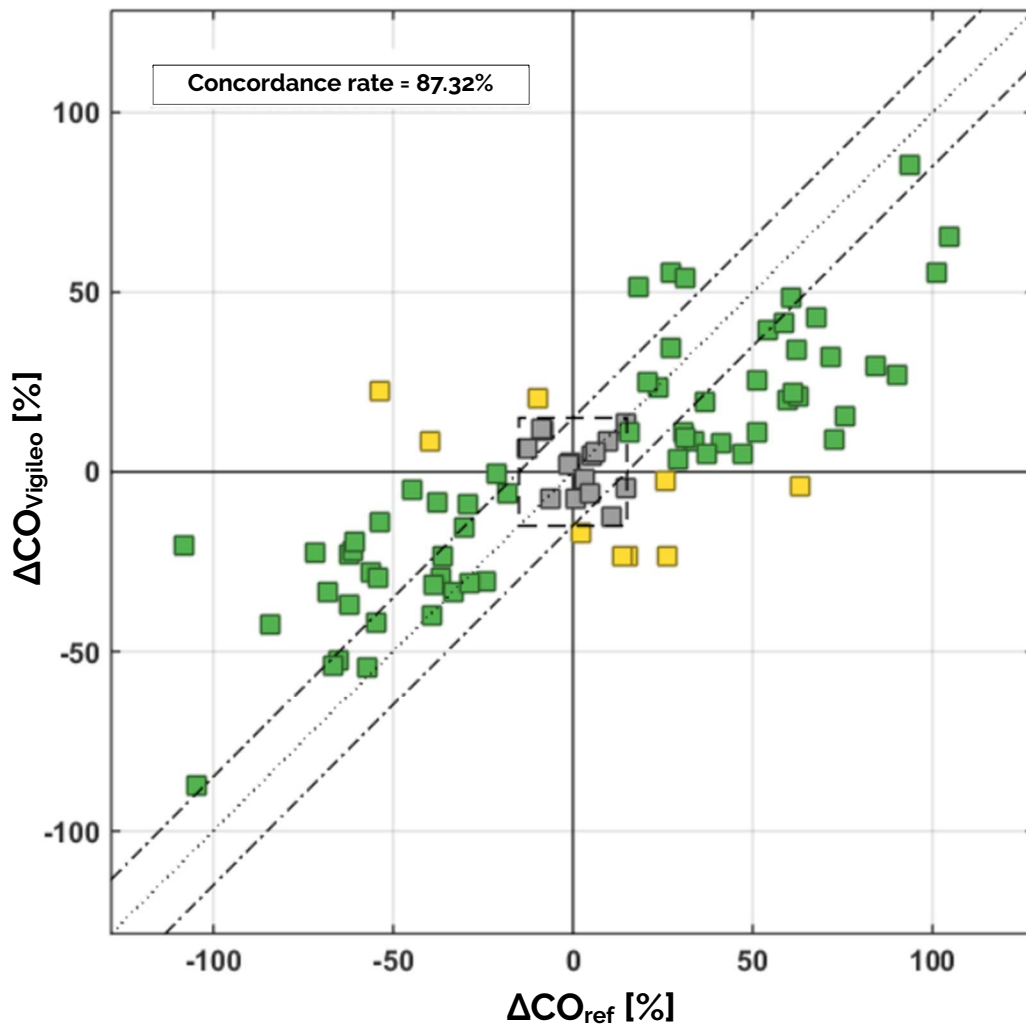

Fig. 6-11: Concordance plot for percentage changes in Vigileo CO versus percentage changes in reference CO

7 Manufacturer's Declaration

Retia Medical Systems, Inc. Headquarters

333 Westchester Avenue
White Plains, NY 10604
(+1) 914 437 6704
info@retiamedical.com

7.2 Monitor Disposal

Before disposing, to avoid contamination of individuals, the environment, or other equipment, make sure the monitor and/or cables are properly disinfected and decontaminated in accordance with local and national laws regulating the disposal of equipment containing electrical and electronic parts.

For single-use parts and accessories, where not otherwise specified, follow local and institutional regulations regarding disposal of hospital waste.

7.3 Warranty

Retia Medical (Retia) warrants that the Argos Cardiac Output Monitor is fit for the purposes and indications described in the labeling for a period of one (1) year from the date of purchase when used in accordance with the directions for use. Unless the equipment is used in accordance with such instructions, this warranty is void and of no effect. No other express or implied warranty exists, including any warranty of merchantability or fitness for a particular purpose. This warranty does not include cables and connectors used with the Argos Cardiac Output Monitor. Retia Medical's sole obligation and purchaser's exclusive remedy for breach of any warranty shall be limited to repair or replacement of the Argos Cardiac Output Monitor at Retia Medical's option. Retia Medical shall not be liable for proximate, incidental, or consequential damages. Retia Medical shall not be obligated under this warranty to repair or replace a damaged or malfunctioning Argos Cardiac Output Monitor if such damage or malfunction is caused by the customer's use of accessories other than those certified by Retia Medical.

Index

4-way stopcock	7, 8, 22, 23, 32, 33
accessories.....	iv, 8, 23, 111, 114, 116, 132
Add Patient Data.....	24, 34, 35, 62
alarms.....	14, 24, 39, 113
alcohol.....	117
alerts.....	26, 41, 110, 111, 115, 118
limits.....	25, 26, 42, 49, 111, 118
analog output.....	21
aortic valve regurgitation	1
Argos monitor.....	iv, 1, 4, 5, 6, 7, 8, 15, 16, 17, 18, 20, 21, 22, 23, 24, 32, 34, 36, 39, 40, 110, 114, 115, 116, 117
about.....	64
accessories.....	132
alcohol.....	116
bleach.....	116, 117
cleaning.....	116
damage.....	4, 5, 7, 8, 12, 21, 22, 132
decontaminate.....	132
dimensions.....	112
disinfect.....	132
purposes.....	132
replacement.....	116, 132
serial number.....	118
software.....	iv, 64
Support.....	116
Table/pedestal stand.....	113
version.....	iv, 64, 116
wear.....	117
weight.....	112
arrhythmias.....	5
arterial.....	1, 2, 5, 6, 7, 8, 17, 21, 23, 32, 33, 43, 53, 110, 113, 114, 119
line.....	7, 8, 21, 23, 40
averaging time.....	115
bar.....	31, 32
baseline.....	79
battery.....	21, 32, 59, 110
icons.....	59
operation.....	59
bedside patient monitor.....	2, 5, 7, 8, 10, 21, 22, 24, 32, 33, 39, 40, 112, 113, 114
bibliography.....	119
biohazard.....	8, 23
Bland-Altman plot.....	122
blood pressure.....	2, 5, 24, 42, 114
BP.....	ii, 2, 17, 39, 40, 42, 110, 111, 114, 115
signal.....	110, 111
bolus.....	119
BP Transducer Kit.....	32, 33
cable.....	6, 8, 9, 16, 17, 18, 20, 21, 22, 23, 110, 117, 118, 132
Cardiac Index.....	2, 42, 46, 47, 114
CI.....	2, 42, 46, 47, 114, 115
Cardiac Output.....	iv, 1, 2, 8, 22, 24, 42, 45, 46, 59, 111, 114
CO.....	2, 42, 43, 45, 46, 49, 110, 111, 112, 114, 115
Monitor.....	iv, 15, 24, 59, 111, 113
cardiac support.....	1

catheter	6, 7, 17, 21, 32, 33, 110, 119
caution.....	iv, 4, 8, 17, 18, 21, 22, 24, 59, 67, 92, 105, 116, 117
chronology	70
clinician.....	iv
color.....	26, 42, 47, 48, 59, 66, 115
concordance plot.....	123, 124
Conducted Immunity.....	ii
Connectivity Kit.....	87
connectors.....	17, 18, 117, 132
corrosion.....	18, 117
data	
capacity	35
export.....	10, 18, 36, 60, 62, 63
port.....	10, 62, 117
Data I/O label.....	10
date	60, 66, 67, 115
and time	32, 60, 65, 66, 83
defaults.....	34, 44, 51, 52, 53, 54, 60, 66, 115
restore defaults.....	55, 60, 66
defibrillation.....	14, 22, 113
definition	2
demographic.....	34, 35, 37, 39, 61, 83
Diastolic pressure.....	110
directions for use.....	132
Display.....	112
disposal	8, 23, 132
download.....	iv
Draeger.....	113
Dynamic Assessment.....	31, 46, 58, 70
History.....	58
electrocautery.....	ii
equipment.....	17
electrolytic solution.....	18, 117
electromagnetic	
environment.....	i
immunity.....	i, ii
interference	ii, 110
Electronic Medical Records (EMR).....	iii, 64, 67, 84, 85, 87, 92, 93, 102, 103, 104
Capsule.....	87, 103, 104
Capsule – via Ethernet or Serial.....	102
Corepoint.....	38, 87, 91, 102, 104
Electrostatic discharge.....	i
electrosurgical equipment.....	110
emissions.....	i, 8, 18, 23
EMR.....	87
End Patient Session.....	36
equations.....	114
errors.....	iii, 63, 110, 111, 118
events.....	59, 68, 69, 70
event history.....	69, 70
Flags.....	70
Events access indicator.....	58
excitation voltage.....	7, 18, 20, 117
expired baseline.....	81

external monitor	10
femoral.....	iii, 1, 2, 6, 7, 17, 21, 32, 33, 40, 111, 119, 125
FG-008: Network Connectivity Kit.....	87
FG-009: Serial Connectivity Kit.....	87
fluid bolus	58, 71, 72
fluid responsive	78
GE	113
Solar Monitors	113
glutaraldehyde	117
graph	53
hazard	4, 6, 7, 8, 17, 22, 110, 116
heart rate	2, 42, 114
HR	2, 42, 114, 115
hemodynamic	1, 46, 55, 67, 87, 102, 110, 111, 114, 119
HL7 protocol.....	87
hypertension	110
hypotension	110
incision	125
indications.....	132
for use	1, 5, 50, 59, 111
ingress	5, 14, 16, 113
insulation	117
intra-aortic balloon pump.....	1
Invalid Baseline.....	80
keyboard	68, 69, 70
label.....	4, 9
labeling	132
Lactated Ringers	18, 117
LAN.....	87, 97, 113
License.....	38, 59, 64, 67, 84, 87, 92, 93, 94, 95, 96, 97
logs.....	59
LVAD	1
maintenance.....	iv, 116
malfunction	110, 132
Manufacturer's Declaration of Conformity Electronic Emissions and Immunity	i
Mean Arterial Pressure.....	2, 42, 43, 53, 114
MAP	2, 24, 42, 43, 44, 50, 53, 54, 114, 115
menu	31, 32, 58, 59, 60, 61, 62
bar.....	58
Mindray	113
monitor disconnected from AC.....	59
motion artifact	110
mount.....	2, 6, 15, 16
MRI scanner	7
NaCl	18, 117
navigation.....	8, 60
network.....	i, 38, 59, 84, 87, 92, 99, 100, 102, 103, 104, 110, 117
Network galvanic isolator	87
No Signal Detected timeout.....	86
noise	110, 111
non-responsive result	75
not fluid responsive	78
parameter.....	iv, 1, 2, 24, 25, 26, 39, 42, 43, 44, 45, 46, 47, 48, 49, 53, 66, 102, 110, 111, 112, 113, 114, 115
index.....	26

limits.....	iv, 39, 47, 66
ranges.....	53, 54, 66, 112
parts and accessories.....	113, 132
Passive Leg Raise.....	31, 58, 71, 76
patient. iv, 1, 4, 5, 6, 7, 8, 16, 17, 20, 21, 22, 24, 32, 33, 34, 35, 36, 37, 39, 40, 41, 45, 59, 60, 61, 62, 67, 110, 117, 118	
ID.....	36, 62
Patient Record Query	102, 104
pediatric patients.....	1, 5
Philips.....	87, 97, 98, 99, 102, 113
EC10	97
EC5.....	97
IntelliVue Monitor	97
phlebostatic axis.....	7, 21, 32, 110
power.....	5, 6, 7, 16, 17, 18, 19, 20, 21, 23, 32, 34, 59, 60, 110, 112, 117
label.....	9
supply	i, ii, 5, 6, 12, 16, 19
switch.....	9, 18, 20, 63
Power Frequency Magnetic Immunity.....	ii
pressure tubing	8, 23
pulse.....	2, 5, 7, 20, 42, 110, 114
Pulse Pressure Variation	2, 3, 5, 114
PPV.....	2, 42, 114, 115
quickstart guide	113
radiation.....	6, 17
repair	116, 132
replace	110, 116, 132
reset.....	54
Resume/Restart Previous Patient.....	34, 35, 39, 61, 63
Retia.....	iii, 6, 7, 15, 17, 19, 22, 110, 111, 114, 116, 117, 118, 132
contact	iii, iv, 6, 7, 11, 15, 18, 19, 21, 110, 111, 116, 117, 118
customer support.....	iii, 32, 113
email contact.....	15, 111, 118, 132
RF	
communication equipment.....	18
emissions.....	i
interference	i
screen.....	iv, 24, 25, 32, 34, 35, 37, 39, 40, 41, 42, 47, 48, 49, 53, 58, 61, 62, 63, 66, 68, 70, 112
sensor	8, 23
Serial Connectivity Kit.....	113
service	116, 118
manual.....	113
settings	26, 27, 31, 42, 43, 44, 45, 47, 49, 51, 52, 53, 54, 55, 59, 60, 65, 66, 67, 115
advanced.....	65, 67, 68, 92, 93, 94, 96, 99, 101, 102, 105
setup.....	15, 22, 24, 32, 34
Show % change.....	45, 46, 47, 115
shut down	59, 63, 117
signal quality	17, 110
software.....	92, 110
upgrade.....	67, 68, 84, 92, 93, 105, 106, 107, 108, 109
Spacelabs Xprezzon.....	113
specifications	iii, 6, 7, 17, 22, 111, 112, 114
alerts	115
Ambient Pressure.....	112
Electrical.....	111, 112
Frequency	112

Power Consumption	112
Voltage.....	112
Environmental.....	111
Humidity.....	112
Mechanical.....	111, 112
Operating Conditions.....	111
Physical.....	111, 112
temperature	6, 8, 17, 112
standard	i, ii, 6, 14
air pressure.....	6, 17
electrical protection class.....	113
equipment class.....	113
humidity.....	6, 11, 17
IEC.....	6, 14, 17, 113
IP.....	14, 16, 113
rating	11
ISTA.....	14, 113
temperature	11
WEEE.....	11
Start New Patient Session	34, 36, 37
Storage.....	111, 112
Stroke Volume	2, 46, 114
SV.....	2, 42, 46, 48, 114, 115
SVI.....	26
Stroke Volume Index.....	2, 26, 114
SV.....	26
SVI.....	2, 42, 46, 114, 115
Systemic Vascular Resistance.....	2, 114
SVR.....	2, 42, 114, 115
Systemic Vascular Resistance Index.....	2, 114
SVRI.....	2, 42, 114, 115
Systolic Pressure	110
tabular view.....	24, 27, 28, 29, 30, 55, 56, 57, 58
tampering.....	iii, 4, 6, 19, 116
thermodilution.....	119, 125
time	27, 32, 45, 60, 67, 68, 69, 115
movement	25, 49, 50
scale.....	51, 52, 53, 66
Trademark.....	iii
transducer.....	iii, 1, 6, 7, 8, 10, 16, 20, 21, 22, 23, 32, 33, 39, 40, 41, 59, 62, 110
Interface Cable.....	32, 33
line-in.....	10
Re-zero transducer	62
stopcock	41, 110
Zero	40, 41, 62, 110
Transport.....	111, 112
Trend screen.....	24, 25, 39, 42, 44, 49, 51, 52, 53, 54, 63, 69, 70
coordinates	27, 53, 54
scrubbing	31
Trend scrubbing	57
units.....	2, 6, 8, 17, 23, 34, 52, 60, 66, 114, 116
unstable baseline.....	79
UPS.....	ii
use	iv, 1, 4, 5, 6, 7, 8, 12, 15, 16, 17, 18, 19, 20, 21, 22, 23, 24, 25, 26, 34, 35, 36, 39, 40, 44, 54, 59, 60, 61, 68, 69, 70, 110, 111, 116, 117, 132
user guide (manual).....	iv, 4, 8, 11, 23

user interface 112

Utah Medical 113

ventilation..... 6, 17

verification failed 110, 118

vital signs monitor 10, 110

Voltage Dips and Interrupts..... ii

Voltage Fluctuations..... i

WARNING..... iii, iv, 1, 3, 4, 5, 6, 7, 8, 12, 15, 16, 17, 19, 20, 21, 22, 23, 24, 32, 34, 35, 36, 39, 40, 60, 61, 63, 110, 113, 114, 116, 118

warranty 132

waste 8, 23, 132

water..... 116, 117