

Argos Cardiac Output Monitor



Operator's Manual

60-001 Rev H 15-May-2023



The Retia Medical Argos Cardiac Output Monitor Operator's Manual



WARNING

Do not use the Argos monitor if the monitor shows evidence of having been opened or tampered with. If the monitor shows signs of tampering, the monitor should be immediately returned to Retia for inspection. Please call Retia Medical customer support to report the issue and receive assistance.

Prices and specifications are subject to change without notice. If this manual is changed, it will be re-issued. If, during the use of this manual, errors, omissions or incorrect information are discovered please contact Retia Medical.



Issued by:
Retia Medical Systems, Inc.
333 Westchester Ave.
White Plains, NY, 10604
USA



For EU Customers Only:
RQMIS AREU S.L.U.
Diagonal 409-1st Floor,
Barcelona, Catalunya,
CP:8008 Spain



Trademark: Retia Medical, the Retia Logo, Retia, Argos and MBA (multi beat analysis) are trademarks of Retia Medical Systems, Inc. All other trademarks are the property of their respective owners

Copyright 2023 Retia Medical Systems, Inc. All rights reserved.

Manufacturer's Declaration of Conformity Electronic Emissions and Immunity

Guidance and Manufacturer's Declaration – Electromagnetic Emissions		
The Argos monitor is intended for use in the electromagnetic environment specified below. The customer or the user of the Argos should ensure that it is used in such an environment.		
Emissions Test	Compliance	Electromagnetic environment
RF emissions. CISPR 11	Conducted Emissions Class B	The Argos uses RF energy only for internal function therefore RF emissions are low and are not likely to cause any interference with nearby electrical equipment.
RF emissions. CISPR 11	Radiated Emissions Class B	The Argos is suitable for use in all establishments, including domestic establishments and those directly connected to the public low-voltage power supply network that supplies buildings used for domestic purposes.
Harmonic Emissions IEC 6100-3-2	Class D	
Voltage Fluctuations/Flicker Emissions IEC 61000-3-3	Complies	

Guidance and Manufacturer's Declaration – Electromagnetic Immunity			
The Argos is intended for use in the electromagnetic environment specified below. The customer or the user of the Argos should ensure that it is used in such an environment.			
Immunity Test	IEC 60601 Test Level	Compliance Level	Electromagnetic Environment Guidance
Electrostatic discharge (ESD). IEC 61000-4-2 Ed. 2.0 2008-12	±15kV Air ±8kV Contact	Complies	Floors should be wood, concrete, or ceramic tile. If floors are covered with synthetic material, the relative humidity should be at least 30%.
RF interference. IEC 61000-4-3 Radiated Immunity	80-1000 MHz,	20V/M	RF generating equipment should be used no closer to the Argos or connected cables than the recommended separation distance, according to the following formulas:
RF Interference. IEC 61000-4-3 Radiated Immunity	1.0 to 2.7GH	20V/M	

Guidance and Manufacturer's Declaration – Electromagnetic Immunity (cont'd)			
Immunity Test	IEC 60601 Test Level	Compliance Level	Electromagnetic Environment Guidance
			$d = \sqrt{p} * 1.17$ for 150kHz to 80MHz $d = \sqrt{p} * .175$ for 80MHz to 800MHz $d = \sqrt{p} * 0.35$ for 800MHz to 2.5GHz Devices marked with this symbol are known to be sources of RF energy. 
Voltage Dips, short interruptions and voltage variations on power supply lines. IEC-61000-4-4 Ed 3.0 2012-04 Electrical Fast Transient Burst, Power Ports	.5kV, 1KV, 2kV, +/-, 100Khz, 5ns risetime, 50ns pulse duration, 300ms burst period, 0.75ms burst duration	Complies	Mains power quality should be that of a typical commercial or hospital environment. If user of the monitor requires continued operation during power mains interruptions, the monitor uses a built in UPS for environments where power is intermittent. Where d is distance measured in meters, and p is the power in watts of the device generating RF energy.
Power Surge IEC 6100-4-5	.5kV, 1KV Differential, .5kV, 1kV, 2kV Common Mode	Complies	
Conducted Immunity – IEC61000-4-6 ed. 4.0:2013-10.	.15 to 80MHz coupling to power port, external monitor cable, BP transducer cable	Complies	
Power Frequency Magnetic Immunity IEC61000-4-8 Ed 2, 2009-09.	30A/m RMS 50 and 60 Hz	Complies	
Voltage Dips and Interrupts IEC61000-4-11.	10, 20, 500, 5000 msec @ 230VAC, 8.3, 16.67, 500, 5000 msec @ 120VAC	Complies	

As use of electrocautery equipment can interfere with patient monitors and therefore blood pressure waveforms, and can also interfere with the RF susceptibility of the Argos monitor, it is not recommended to rely on cardiac output calculations until 5 minutes after the electrocautery tools have stopped being used.

Recommended separation distance between portable and mobile RF communication equipment and the Argos Monitor:

The Argos is intended for use in an electromagnetic environment in which radiated RF disturbances are controlled. The customer or user of the Argos can help prevent electromagnetic interference by maintaining a minimum distance between portable and mobile RF communications equipment (transmitters) and the Argos as recommended below, according to the maximum output power.

Rated power output of the transmitter in Watts	150kHz to 80MHz $d = \sqrt{p} * 1.17$ in Meters	80MHz to 800MHz $d = \sqrt{p} * .175$ in Meters	800MHz to 2.5GHz $d = \sqrt{p} * 0.35$ in Meters
0.01W	0.117M	0.018M	0.035M
0.1W	0.37M	0.06M	0.11M
1W	1.17M	0.175M	0.35M
10W	3.7M	.55M	1.1M
100W	11.7M	1.75M	3.5M

These guidelines may not apply in all situations. Electromagnetic propagation is affected by absorption and reflection from structures, objects, and people.

Introduction

The Argos Cardiac Output Monitor is a medical device incorporating the multi-beat analysis (MBA™) algorithm that models the patient's vascular resistance to accurately measure cardiac output (CO) in high-risk patients in critical care facilities, using a radial or femoral arterial blood pressure signal.

Portability and ease of connection with bedside patient monitors, combined with a user interface that can be operated quickly and intuitively, as well as interoperability with electronic medical records (EMR) systems, make the Argos a valuable tool for clinicians to verify the hemodynamic status of the patient.

Compatible Monitors

The Argos monitor is compatible with the analog output of the following patient monitors:

- 1. Philips IntelliVue® Models MP40 and above (MP90, MX700, MX800) which accept the M1006B module with option #C01 Pressure Module**
- 2. GE Carescape® Models with Patient Data Module (PDM) Solar 8000, Carescape B650, Carescape B850**
- 3. Spacelabs Xprezzon®**
- 4. Draeger Infinity®**
- 5. Mindray BeneVision® N series with MPM MP1 Module**
- 6. Nihon Kohden Life Scope G9® BSM-6000®, 3500 and 1700 Bedside Monitors**

Please consult the Retia Medical website (www.retiamedical.com) for updates to this list.

Compatible Femoral/Radial Transducers

The Argos monitor is compatible with the following blood pressure transducer components:

- 1. Utah Medical BP Transducer Kit (pack of 25 – 902-649)**
- 2. Utah Medical Transducer Interface Cable (650-299-117)**

Note: These components are manufactured and distributed by Utah Medical.

How to use this manual

The Argos Cardiac Output Monitor Operator's Manual is intended for trained clinical care clinicians for use with the Argos monitor.

Do not operate the Argos monitor before reading this operator's manual and familiarizing oneself with the device's functions and capabilities for appropriate clinical use.

This Operator's Manual offers instruction and guidance on setting up and operating the Argos monitor on critically ill patients. It covers:

- Making necessary connections to other devices
- Changing which parameters are displayed and in what form
- Navigating through informational screens
- Recalling and downloading patient monitoring information
- Care and maintenance of the Argos monitor
- Contacting the manufacturer
- Approved accessories
- Parameters and limits, and physical descriptions of the Argos monitor

This manual is organized into sections which, consulted sequentially, show a new user how to operate the device, and also serve as reference for the experienced operator.

Pay particular attention to highlighted and offset text, marked as cautions or warnings (⚠) or notes (↪).



CAUTION

Illustrations, including device images and screenshots, are solely intended as reference and may not precisely represent the hardware or software version of the Argos monitor the user is using.

Table of Contents

Manufacturer's Declaration of Conformity Electronic Emissions and Immunity.....	1
Compatible Monitors.....	4
1 Intended Use.....	1
1.1 Indications for Use.....	1
1.2 Intended Use.....	1
1.3 Contraindications.....	1
1.4 Not Intended as a Blood Pressure Monitor.....	1
1.5 Parameters.....	2
1.5.1 Pulse Pressure Variation.....	3
2 Warnings, Cautions, Notes, Symbols and Standards.....	4
Warnings, Cautions and Notes.....	4
2.1 Device Labels.....	10
2.2 Shipping Label.....	14
2.3 Standards Compliance.....	15
3 Initial Setup.....	16
3.1 Mounting the Argos.....	16
4 Basic Navigation.....	25
4.1 Overview.....	25
4.2 The Touchscreen Interface.....	25
4.3 Entering Patient Data.....	26
4.4 Select Blood Pressure Source.....	30
4.5 Zero Transducer.....	31
4.6 The Trend Screen.....	32
4.6.1 Selecting a different parameter.....	33
4.6.2 Changing Trend Settings on the Trend Screen.....	36
4.7 End Session / Shut Down.....	39
4.7.1 Shut down.....	41
5 Using the Argos Monitor.....	43
5.1 Guide to screens.....	43
5.2 Trend Scrubbing.....	50
5.3 The Control Bar & Status Bar.....	50
5.4 The Setup Screens.....	51
5.4.1 Prepare patient.....	51
5.5 Initial setup – Input patient data.....	53
5.6 Search Patient Record Database.....	58
5.7 Steps before monitoring.....	60
5.7.1 Connected to a bedside patient monitor:.....	60
5.7.2 Connected directly to a radial or femoral artery transducer:.....	61
5.8 The Trend Screen.....	62
5.8.1 The Parameter Settings Screen.....	63
5.8.2 Display change since event.....	66
5.8.3 Display an associated index or value.....	69
5.8.4 Changing colors and graph limits.....	70

5.8.5 To change alert limits:.....	72
5.8.6 Moving chronologically through trends.....	74
5.9 Trend Settings.....	75
5.9.1 Scaling trends.....	75
5.9.2 Trend settings: Scaling trends.....	77
5.9.3 Changing the graph range (y-axis).....	79
5.10 The Tabular View.....	81
5.10.1 Tabular view options.....	82
5.10.2 Trend scrubbing in Tabular View.....	84
5.11 The Control Bar & Status Bar.....	85
5.11.1 Battery State Indicator.....	86
5.11.2 The User Menu.....	88
5.11.3 End Session.....	89
5.11.3.1 Re-Zero Transducer.....	89
5.11.4 Export.....	90
5.11.5 Shut Down.....	92
5.11.6 About.....	93
5.11.6.1 Device Settings.....	95
5.11.6.2 Reset to default configuration.....	96
5.11.6.3 Language, Date, and Time.....	97
5.11.6.4 Monitoring Mode.....	98
5.11.6.5 Advanced Settings.....	98
5.11.6.6 Events.....	99
5.12 Dynamic Assessment Functionality.....	101
5.12.1 Assessment types.....	102
5.12.2 Canceling an Assessment.....	102
5.12.3 Fluid Bolus Assessment.....	102
5.12.4 Passive Leg Raise (PLR) Assessment.....	107
5.12.4.1 Baselines.....	110
5.12.4.2 Unstable Baseline.....	110
5.12.4.3 Invalid Baseline.....	112
5.12.4.4 Expired Baseline.....	113
5.12.5 Dynamic Assessment History.....	113
5.13 Date and Time indicator.....	115
5.14 Patient Demographics.....	115
5.15 EMR indicator (<i>licensed versions</i>).....	115
5.16 Monitoring Mode of Operations.....	117
5.17 No Signal Detected timeout.....	117
6 EMR (Electronic Medical Records) Integration.....	119
6.1.1 Entering Patient Data (<i>Licensed Version - Corepoint</i>).....	119
7 Software Management.....	124
7.1 Activating Advanced Settings.....	124
7.1.1 Installing the software license to enable EMR.....	125
7.1.2 Verifying the software license has been installed.....	125
7.1.3 License installation.....	128
7.1.4 Configuring EMR service connectivity.....	130
7.2 Philips Monitor Settings.....	130

7.2.1 Troubleshooting the Philips Monitor Connection.....	131
7.3 Network Settings.....	132
7.4 Configuring EMR servers.....	135
7.4.1 EMR Platform.....	135
7.4.1.1 Patient Record Query.....	135
7.4.2 Adding EMR Server Entries.....	136
7.5 Updating the software.....	138
8 Help.....	143
8.1 Specifications.....	144
8.2 Equations for Calculated Patient Parameters.....	148
8.3 Default Settings.....	150
8.4 Unit Conversions.....	150
8.4.1 lbs to/from kg.....	150
8.4.2 inches to/from cm.....	150
8.5 Care, Service, and Support.....	150
8.6 Cleaning the Monitor.....	151
8.7 Monitor Maintenance.....	151
8.8 Cable Maintenance.....	151
8.9 Data Port Maintenance.....	152
8.10 Expected Service Life.....	152
8.11 Service and Support.....	153
8.12 Alert Functionality Verification.....	153
9 Clinical Studies.....	154
9.1 Chapter Overview.....	154
9.1.1 Results:.....	155
10 Manufacturer's Declaration.....	168
10.1 Retia Medical Systems, Inc. Headquarters.....	168
10.2 Monitor Disposal.....	168
10.3 Warranty.....	168

List of Figures

Fig. 2-1: Device Shipping Label.....	14
Fig. 3-1: Rear view, showing mount holes.....	16
Fig. 3-2: Power supply shown mounted correctly, with arrows pointing upward.....	17
Fig. 3-3: View from top right, showing power input and power switch.....	19
Fig. 3-4: Left and right side views.....	20
Fig. 3-5: Left side port panel, showing inputs for transducer (top) and monitor line-in (middle)	21
Fig. 3-6: Right side power panel, showing power cable input and power switch.....	21
Fig. 3-7: Power label instructions.....	21
Fig. 3-8: AC adapter label indicating proper orientation on pole stand.....	21
Fig. 3-9: Standard patient line, from transducer to monitor to Argos.....	22
Fig. 3-10: Transducers connected to Argos and bedside patient monitor.....	23
Fig. 4-1: Front view of Argos monitor.....	25
Fig. 4-2: On power up the Add Patient Data screen appears.....	26
Fig. 4-3: Metric units selected.....	26
Fig. 4-4: Units buttons.....	26
Fig. 4-5: Touch a field to bring up the virtual keyboard.....	27
Fig. 4-6: Setup screen ready for Patient ID entry.....	28
Fig. 4-7: Touch the Enter key to register the value and proceed.....	28
Fig. 4-8: Use the keypad to enter demographic information.....	29
Fig. 4-9: Press Save to continue to BP Source selection.....	29
Fig. 4-10: Choose whether patient is connected via a transducer or bedside monitor.....	30
Fig. 4-11: Verify patient demographic information is correct before proceeding.....	30
Fig. 4-12: Transducer shown selected; press Next to continue.....	30
Fig. 4-13: Ready to zero transducer.....	31
Fig. 4-14: Press finish to begin patient monitoring.....	32
Fig. 4-15: The default trends.....	32
Fig. 4-16: Parameter label field shown highlighted.....	33
Fig. 4-17: To switch parameters, tap the parameter label.....	34
Fig. 4-18: Tap the label to choose a different trend.....	34
Fig. 4-19: The dropdown list of parameters.....	35
Fig. 4-20: MAP shown selected.....	35
Fig. 4-21: Press Save to continue.....	36
Fig. 4-22: MAP displays.....	36
Fig. 4-23: The default interval is 10 minutes.....	37
Fig. 4-24: The Time Scale selector.....	38
Fig. 4-25: Tapping the Time Scale box opens up a selection box.....	38
Fig. 4-26: Select the desired timescale, press Save to continue.....	39
Fig. 4-27: Waveforms display in 30-minute intervals.....	39
Fig. 4-28: Touch the Menu icon to activate the User Menu.....	40
Fig. 4-29: The User Menu.....	40
Fig. 4-30: Press End Session to end the current session and start a new one.....	41

Fig. 4-31: Verify ending session.....	41
Fig. 4-32: Select Shut Down.....	42
Fig. 4-33: Confirm Shutdown.....	42
Fig. 5-1: The Add Patient Data screen.....	43
Fig. 5-2: The Trend Screen.....	44
Fig. 5-3: Parameter settings.....	46
Fig. 5-4: Trend settings.....	46
Fig. 5-5: Tabular view.....	47
Fig. 5-6: The Tabular View tab.....	47
Fig. 5-7: Use a fingertip to drag upward from the bottom of the Trend screen.....	48
Fig. 5-8: Touch Switch to Tabular view on the user menu.....	48
Fig. 5-9: The Trend View tab.....	49
Fig. 5-10: Use a fingertip to drag downward from the top of the Tabular View.....	49
Fig. 5-11: Touch Switch to Trend View on the user menu.....	50
Fig. 5-12: Trend values shown on trends.....	50
Fig. 5-13: Status bar and control bar shown highlighted.....	51
Fig. 5-14: Control bar elements.....	51
Fig. 5-15: Status bar elements.....	51
Fig. 5-16: Transducer.....	52
Fig. 5-17: Left side view, showing bedside patient monitor and transducer inputs.....	53
Fig. 5-18: Initial setup screen: Add Patient Data.....	54
Fig. 5-19: Metric units shown selected.....	54
Fig. 5-20: Touch Use Previous Patient.....	55
Fig. 5-21: Verify previous patient information is correct.....	55
Fig. 5-22: Tapping Enter opens the alphanumeric keypad.....	56
Fig. 5-23: Press OK to save and continue entering data.....	57
Fig. 5-24: Select from the Gender drop down.....	57
Fig. 5-25: Use the virtual keypad to enter numeric values.....	58
Fig. 5-26: Save entered data and proceed.....	58
Fig. 5-27: Search for Patient Record (Corepoint).....	59
Fig. 5-28: Search for patient record continued.....	59
Fig. 5-29: Verifying patient record.....	59
Fig. 5-30: Select BP Signal Source.....	60
Fig. 5-31: "Bedside Monitor" selected; press Next.....	61
Fig. 5-32: Select Transducer and then press Next.....	61
Fig. 5-33: The Zero transducer screen.....	62
Fig. 5-34: Press finish to begin patient monitoring.....	62
Fig. 5-35: The Trend screen.....	63
Fig. 5-36: Press any parameter label to change the displayed trend.....	64
Fig. 5-37: Tap the current trend name inside the box to change it.....	64
Fig. 5-38: The drop down list of trends.....	65
Fig. 5-39: MAP selected. Press Save to continue.....	65
Fig. 5-40: MAP displayed.....	66
Fig. 5-41: Touch the label to access Parameter settings.....	67
Fig. 5-42: "Show % change" shown highlighted.....	67
Fig. 5-43: "Show % change" box checked.....	68
Fig. 5-44: Percentage change is measured from the flagged event.....	68

Fig. 5-45: "Show CI" selection box highlighted.....	69
Fig. 5-46: Tick the box, then tick Save.....	70
Fig. 5-47: CI now displayed in Parameter label.....	70
Fig. 5-48: The Color selector.....	71
Fig. 5-49: Color selection.....	71
Fig. 5-50: Blue is selected.....	72
Fig. 5-51: SV trend and label displayed in blue.....	72
Fig. 5-52: High limit adjuster in Parameter settings.....	73
Fig. 5-53: Increase the limit with the upturned triangle.....	73
Fig. 5-54: CO upper alert limit reached.....	74
Fig. 5-55: A fingertip touching the MAP trend brings up a gray triangle.....	74
Fig. 5-56: Closer view of trend and label.....	75
Fig. 5-57: Arrows at both ends of the trend indicate an earlier view.....	75
Fig. 5-58: Draw two fingertips together to compress the time scale.....	75
Fig. 5-59: All three trends are lengthened to approximately one hour.....	76
Fig. 5-60: Time scale is 30 minutes before manual adjustment.....	76
Fig. 5-61: The time scale is approximately 10 minutes.....	76
Fig. 5-62: Default trend time scale is 10 minutes.....	77
Fig. 5-63: Access Trend settings by pressing a trend.....	77
Fig. 5-64: Time scale is shown on Trend settings.....	78
Fig. 5-65: Time scale intervals range from 10 minutes to 12 hours.....	78
Fig. 5-66: 30 minute interval selected, press Save to continue.....	79
Fig. 5-67: All trends are scaled at 30 minute intervals.....	79
Fig. 5-68: Set MAP graph range values here.....	80
Fig. 5-69: MAP trend settings with max graph value selector highlighted.....	80
Fig. 5-70: Max graph range value is now 140 mL.....	81
Fig. 5-71: Press Reset all trend options to return settings to defaults.....	81
Fig. 5-72: Tabular View.....	82
Fig. 5-73: Tap the desired interval.....	82
Fig. 5-74: Data is now shown in 30-minute intervals.....	83
Fig. 5-75: Touch the double arrow to rewind or fast-forward data.....	84
Fig. 5-76: Data rewound to start of monitoring session.....	84
Fig. 5-77: Drag rightwards for earlier values.....	85
Fig. 5-78: Drag leftwards for later values.....	85
Fig. 5-79: Control Bar elements.....	86
Fig. 5-80: Status Bar elements.....	86
Fig. 5-81: Touch the three-lined User Menu navigation icon to access it.....	88
Fig. 5-82: The User Menu.....	88
Fig. 5-83: End Session confirmation screen.....	89
Fig. 5-84: Re-zero transducer screen.....	90
Fig. 5-85: Export data.....	91
Fig. 5-86: Tap the Export box.....	91
Fig. 5-87: Exporting confirmation popup.....	92
Fig. 5-88: Insert a formatted USB drive.....	92
Fig. 5-89: Confirm shutdown.....	93
Fig. 5-90: The About screen provides software and firmware information.....	94
Fig. 5-91: About screen (Licensed versions).....	94

Fig. 5-92: EMR software licenses have expired.....	95
Fig. 5-93: The Settings menu, top.....	95
Fig. 5-94: The Settings menu, bottom.....	96
Fig. 5-95: Reset to default configuration selector.....	96
Fig. 5-96: Confirm reset to defaults.....	97
Fig. 5-97: The Settings menu (during patient monitoring session).....	98
Fig. 5-98: Tap the flag icon to notate or recall events.....	99
Fig. 5-99: Event marking screen, with Mark Event selected.....	99
Fig. 5-100: Description of event.....	100
Fig. 5-101: The Event History tab.....	100
Fig. 5-102: Edit event.....	101
Fig. 5-103: Press cancel to recall the Trend screen.....	101
Fig. 5-104: Press cancel to end assessment and go back to trend screen.....	102
Fig. 5-105: Press the fluid bolus Icon to start the challenge.....	103
Fig. 5-106: Select between the two bolus sizes.....	103
Fig. 5-107: Argos prompts to create new baseline.....	104
Fig. 5-108: Press Next to create new baseline.....	104
Fig. 5-109: 3 minute timer countdown to create baseline for bolus fluid assessment.....	105
Fig. 5-110: Begin 250ml or 500ml Bolus infusion.....	105
Fig. 5-111: 7 minute timer countdown for a 250ml bolus.....	106
Fig. 5-112: 12 minute timer countdown for a 500ml bolus.....	106
Fig. 5-113: Report shows that patient is not likely fluid responsive.....	107
Fig. 5-114: Dynamic Assessment, PLR icon located on the Control Bar.....	107
Fig. 5-115: Instruction screen to prepare patient for PLR assessment.....	108
Fig. 5-116: 3 minute countdown timer to measure baseline for PLR assessment.....	108
Fig. 5-117: Instruction screen to inform the user to raise patient's legs by 45°.....	109
Fig. 5-118: PLR challenge screen which takes no more than 3 minutes.....	109
Fig. 5-119: PLR challenge screen reports that patient is likely fluid responsive.....	110
Fig. 5-120: Argos lets user know that the baseline is unstable.....	111
Fig. 5-121: Argos gives the user the option to use the existing baseline or to create a new one.....	111
Fig. 5-122: Argos prompts user to manually create new baseline.....	112
Fig. 5-123: Baseline rejected due to invalid samples.....	112
Fig. 5-124: Monitor prompts user that it's baseline has expired since their baseline is over 15 minutes old.....	113
Fig. 5-125: Dynamic Assessment History Icon can be found on the Control Bar.....	114
Fig. 5-126: Dynamic Assessment History performed during this session.....	114
Fig. 5-127: Dynamic Assessment History entry expanded to show more details.....	115
Fig. 5-128: EMR indicator.....	116
Fig. 5-129: EMR connectivity details.....	117
Fig. 5-130: No BP signal detected warning.....	118
Fig. 6-1: Add Patient Data screen with Search for Patient Record.....	120
Fig. 6-2: Patient record search.....	120
Fig. 6-3: Press Search after typing in the patient record.....	121
Fig. 6-4: Patient record located.....	121
Fig. 6-5: Verifying patient details with the EMR server.....	122
Fig. 6-6: Add patient weight and height, then press Save.....	122

Fig. 6-7: Patient demographics loaded, ready to proceed with monitoring.....	123
Fig. 6-8: Patient verification failed.....	123
Fig. 7-1: Touch Unlock to open Advanced Settings.....	124
Fig. 7-2: Confirm the user is qualified to change Advanced Settings.....	125
Fig. 7-3: Advanced settings, top of screen.....	125
Fig. 7-4: Press Unlock to access Advanced Settings.....	126
Fig. 7-5: Confirm access to Advanced Settings.....	126
Fig. 7-6: Press Manage to verify EMR status.....	127
Fig. 7-7: License Manager display of licensed device information.....	127
Fig. 7-8: Installed license not found.....	128
Fig. 7-9: License ready for installation from USB drive.....	128
Fig. 7-10: Press Import New License.....	129
Fig. 7-11: Software license successfully imported.....	129
Fig. 7-12: License information displayed in License Manager.....	130
Fig. 7-13: Selecting the Philips Monitor Connection.....	131
Fig. 7-14: Connection Status for Philips Monitor Showing no FG-009 Connected.....	131
Fig. 7-15: Connection Status for Philips Monitor Showing Full Functionality.....	132
Fig. 7-16: Select Network/Edit.....	132
Fig. 7-17: Automatic (DHCP) addressing shown selected.....	133
Fig. 7-18: Move the slide to switch off DHCP.....	133
Fig. 7-19: Sample DHCP values filled in.....	134
Fig. 7-20: Use the keyboard to enter network values.....	134
Fig. 7-21: Network settings.....	135
Fig. 7-22: Select EMR/Edit.....	136
Fig. 7-23: The EMR Settings screen.....	136
Fig. 7-24: Capsule server shown selected.....	137
Fig. 7-25: Enter EMR server information.....	137
Fig. 7-26: Edit Patient Record Server details.....	138
Fig. 7-27: Press Save to save and close EMR configuration.....	138
Fig. 7-28: Touch Update.....	139
Fig. 7-29: Select Install to proceed with the software upgrade.....	139
Fig. 7-30: Update complete, please remove the USB stick.....	140
Fig. 7-31: Press Shutdown to reboot the device.....	140
Fig. 7-32: About page showing the upgraded version.....	141
Fig. 7-33: No USB drive detected.....	141
Fig. 7-34: More than one USB drive detected.....	142
Fig. 7-35: No update file found.....	142
Fig. 8-1: Error message displayed, with null trend values.....	144
Fig. 9-1: Regression (unweighted Deming) plot for Retia Argos CO versus reference CO for all patients.....	155
Fig. 9-2: Regression (unweighted Deming) plot for predicate CO versus reference CO for all patients.....	156
Fig. 9-3: Bland-Altman plot comparing Retia Argos CO to reference CO for all patients. LOA [-3.52 to 3.47].....	157
Fig. 9-4: Bland-Altman plot comparing predicate CO to reference CO for all patients. LOA [-2.93 to 4.08].....	158

<i>Fig. 9-5: Concordance plot for percentage changes in Retia Argos CO versus percentage changes in reference CO.....</i>	<i>159</i>
<i>Fig. 9-6: Concordance plot for percentage changes in predicate CO versus percentage changes in reference CO.....</i>	<i>160</i>
<i>Fig. 9-7: Regression (unweighted Deming) plots for Vigileo CO versus reference CO. Pearson's $r = 0.57$; Percentage within error grid = 49%.....</i>	<i>164</i>
<i>Fig. 9-8: Bland-Altman plot comparing Argos CO to reference CO. LOA [-3.43 to 4.93].....</i>	<i>165</i>
<i>Fig. 9-9: Bland-Altman plot comparing Vigileo CO to reference CO. LOA [-4.28 to 4.74].....</i>	<i>165</i>
<i>Fig. 9-10: : Concordance plot for percentage changes in Argos CO versus percentage changes in reference CO.....</i>	<i>166</i>
<i>Fig. 9-11: Concordance plot for percentage changes in Vigileo CO versus percentage changes in reference CO.....</i>	<i>167</i>

List of Tables

Table 1: Parameters, Definitions, and Units.....	2
Table 2: Device Labels Power Supply.....	13
Table 3: Standards compliance.....	15
Table 4: Battery icons.....	87
Table 5: Dynamic Assessment History Headers.....	115
Table 6: EMR status icons.....	116
Table 7: Troubleshooting error messages.....	143
Table 8: Physical and Mechanical Specifications.....	145
Table 9: Electrical Specifications.....	145
Table 10: Environmental Specifications.....	146
Table 11: Parameters.....	146
Table 12: Standards Compliance.....	146
Table 13 Argos Cardiac Output Monitor and Accessory Part Numbers.....	147
Table 14: Hemodynamic Parameters.....	148
Table 15: Technical Details for Dynamic Assessment.....	149
Table 16: Argos Monitor Defaults.....	150
Table 17: Summary statistics including bias, precision, normalized root mean squared error (NRMSE), concordance and root mean squared error for sub-group analyses.....	161
Table 18: Summary statistics including bias, precision, NRMSE and concordance for all data and subgroups. Note that concordance is not calculated for the subgroups due to restricted data.....	162

1 Intended Use

1.1 Indications for Use

The Argos Cardiac Output monitoring device is intended for use on patients above the age of 18. It is intended to be used as a hemodynamic monitor for continuously monitoring cardiac output and its derived parameters on patients in the intensive care unit or the operating room.

1.2 Intended Use

The Argos Cardiac Output monitor is used for the continuous measurement of cardiac output from an intravascular radial or femoral arterial blood pressure signal. This signal is derived from a blood pressure transducer or from the analog output of a vital signs monitor. The device is intended to be used by clinicians on critically ill patients in an operating room or in an intensive care unit.

**WARNING**

Read this manual carefully before attempting to use the Argos monitor

**WARNING**

The Argos monitor is intended solely for use by qualified clinicians who have been trained in its use.

1.3 Contraindications

Use of the Argos monitor is contraindicated given:

- 1) Any type of mechanical cardiac support – e.g., intra-aortic balloon pumps, left ventricular assist devices (LVADs); or
- 2) Moderate to severe aortic valve regurgitation.

**WARNING**

The Argos monitor is not indicated for use with pediatric patients (age < 18).

1.4 Not Intended as a Blood Pressure Monitor

**WARNING**

The Argos monitor should not be used to monitor arterial blood pressure. The arterial blood pressure transducer input on the Argos monitor is to be used only when another arterial blood pressure transducer is connected in parallel to a bedside patient monitor with the appropriate blood pressure alarms.

The Argos monitor is not intended to be used as a blood pressure monitor. The Argos monitor should be used only in conjunction with a bedside patient monitor connected to a radial or femoral artery. If the blood pressure transducer input is used to capture the arterial blood pressure signal, the transducer must be a second transducer connected in parallel with the bedside patient monitor arterial blood pressure transducer.

1.5 Parameters

Table 1: Parameters, Definitions, and Units

Parameter	Abbr.	Defined	Units
Cardiac Output	CO	The amount of blood the heart pumps through the circulatory system in a minute.	L/min
Cardiac Index	CI	The ratio of cardiac output to body surface area.	L/min/m ²
Mean Arterial Pressure	MAP	Average pressure in the arteries during a cardiac cycle.	mmHg
Heart rate	HR	Number of heartbeats per minute.	bpm
Blood pressure	BP	The arterial pressure of blood (systolic/diastolic)	mmHg
Stroke Volume	SV	The volume of blood pumped from the left ventricle per beat.	mL
Stroke Volume Index	SVI	The volume of blood pumped by the heart with each beat, divided by the body surface area.	mL/m ²
Systemic Vascular Resistance	SVR	The resistance to blood flow offered by all of the systemic vasculature, excluding the pulmonary vasculature.	dyne-s/cm ⁵
Systemic Vascular Resistance Index	SVRI	Systemic Vascular Resistance proportional to body size	dyne-s-m ² /cm ²
Pulse Pressure Variation*	PPV	The difference between maximum and minimum pulse pressure over a respiratory cycle, per mean pulse pressure	%

*PPV may not be calculated if the timing or morphology of the BP waveform does not conform to an expected morphology or timing used for pattern recognition. In this case PPV may not be calculated or displayed even though cardiac output numbers are still being calculated.

1.5.1 Pulse Pressure Variation

The monitor displays pulse pressure variation (PPV) calculated using the formula

$$PPV = \frac{(PP_{max} - PP_{min})}{(PP_{max} + PP_{min})/2} \times 100$$

where PP_{max} and PP_{min} are the maximum and minimum pulse pressures over a respiratory cycle. The respiratory period is based on the maximum amplitude of the power spectrum of the BP waveform within the frequency range corresponding to a periodicity of between 2 to 10 seconds. The PPV is displayed in 1% increments.

**WARNING**

Pulse Pressure Variation (PPV) is only valid in patients with closed chests on full control mode ventilation.

**WARNING**

Pulse Pressure Variation (PPV) is unreliable in patients with significant arrhythmia.

2 Warnings, Cautions, Notes, Symbols and Standards

This chapter describes the symbols that appear in the manual or on product labels, including those used to identify warnings, cautions, and notes. A list of all warnings and cautions used in this manual is provided here.

This chapter also includes a list of relevant standards to which the Argos monitor complies.

Warnings, Cautions and Notes

Warnings, **Cautions**, and **Notes** have particular meanings in this manual. **Warnings** and **Cautions** are placed inside a text box containing a caution triangle. Note the difference between a **Warning** and a **Caution**:



WARNING

Calls attention to situations or actions that could result in personal injury or death.



CAUTION

Calls attention to situations or actions that could damage equipment, produce inaccurate data, or invalidate a procedure.

Notes are offset from the left-hand margin and marked with an arrow:

- ↪ ***Notes relevant to the procedure being described are presented primarily in the clinical how-to section of the manual.***



WARNING

Misuse may be a hazard to the patient. Read all warnings and cautions in this section of the manual before using the Argos monitor.

At all times, the following warnings and cautions should be observed when using the Argos monitor:



WARNING

Do not use the Argos monitor if the monitor shows evidence of having been opened or tampered with. If the monitor shows signs of tampering, the monitor should be immediately returned to Retia for inspection. Please call Retia Medical customer support to report the issue and receive assistance.

**WARNING**

Read this manual carefully before attempting to use the Argos monitor.

**WARNING**

The Argos monitor is intended solely for use by qualified clinicians who have been trained in its use.

**WARNING**

The Argos monitor is not indicated for use with pediatric patients (age < 18).

**WARNING**

Severe, persistent arrhythmias may affect accuracy.

**WARNING**

Do not use the Argos monitor as a pulse rate or blood pressure monitor.

**WARNING**

The Argos monitor should *not* be used to monitor arterial blood pressure. The arterial blood pressure transducer input on the Argos monitor is to be used *only* when another arterial blood pressure transducer is connected in parallel to a bedside patient monitor with the appropriate blood pressure alarms.

**WARNING**

Pulse Pressure Variation (PPV) is only valid in patients with closed chests on full control mode ventilation.

**WARNING**

Pulse Pressure Variation (PPV) is unreliable in patients with significant arrhythmia.

**WARNING**

Do not use the Argos monitor if it is damaged. Please contact a representative to report this to Retia Medical.

**WARNING**

Do not use damaged system components.

**WARNING**

Do not attempt to use the Argos monitor if it is not fastened to a stand.



WARNING

During use, the Argos monitor should *never* be placed flat on a surface or balanced on a tabletop or other surface.



WARNING

The Argos monitor and power adapters must be positioned in an upright position to ensure IPX1 ingress protection.



WARNING

Do not position the external power supply in such a fashion that it is difficult to unplug the mains cord in case an emergency requires the monitor to be unplugged.



WARNING

The Argos monitor must be securely mounted. Ensure all cords and cables are placed so they pose no risk of injury to patients, users, or equipment.



WARNING

Ensure there is sufficient room for cables and transducer or monitor lines.



WARNING

To avoid potential fire hazard, if using a pole mount, make sure the power supply is placed on the pole so that the arrows on the label are pointing upward.



WARNING

Do not operate the Argos monitor outside operating specifications for temperature, humidity, and air pressure (see Appendix 8.1, Table A-3). Ensure the device is within operating specifications before use.



WARNING

Ensure there is adequate space around the unit to allow for proper ventilation.



WARNING

Explosion hazard! Do not use the Argos monitor in the presence of any flammable anesthetic mixture with air or with oxygen or nitrous oxide.



WARNING

The Argos monitor is intended solely for use with a radial or femoral arterial catheter. *Do not* attempt to use it with any other kind of patient connection.

**WARNING**

Do not place any foreign items (unapproved 60601-1 items) in any of the Argos monitor ports.

**WARNING**

Equipment that generates high energy, high frequency electromagnetic radiation should not be used in close proximity to this monitor or any other patient monitoring equipment.

**WARNING**

Do not position IEC/EN 60950 equipment, including printers, any closer than 1.5 meters to the patient's bed while the Argos is in use.

**WARNING**

Do NOT use the Argos monitor if signs of tampering are present. Contact a Retia Medical representative.

**WARNING**

Do not attempt to connect a power supply to the monitor that has not been approved for use by Retia Medical.

**WARNING**

To avoid the risk of electric shock, this equipment must only be connected to a supply mains with protective earth.

**WARNING**

Do not use extension cords or multiple socket devices to connect the power adapter.

**WARNING**

Do not connect the Argos monitor to a patient monitor using an AC or pulsed DC pressure transducer excitation voltages.

**WARNING**

The Argos *must* be used in conjunction with an approved bedside patient monitor.

**WARNING**

When using a transducer connected directly to the Argos monitor, make sure the transducer is leveled to the phlebostatic axis.



WARNING

Carefully inspect the radial or femoral arterial line before use.



WARNING

Do not use a transducer or catheter that is damaged or that has exposed electrical contacts.



WARNING

Before operating in conjunction with a bedside patient monitor, consult with a Retia Medical representative to ensure the monitor has compatible specifications.



WARNING

Do NOT use the Argos monitor in proximity to an MRI scanner.



WARNING

A hazard can exist if different alarm/alert presets are used for the same or similar equipment in any single area.



WARNING

Do not attempt to attach or connect a transducer, transducer line, monitor, or monitor line to the Argos monitor which has not been certified for use by Retia Medical.



WARNING

If the Argos monitor is connected directly to a transducer, the patient must also be simultaneously connected to the bedside patient monitor with another transducer via a 4-way stopcock.



WARNING

Shock or fire hazard! Do not immerse the Argos monitor or cables in any liquid solution. Do not allow any fluids to enter the instrument.



WARNING

Use of a damaged cable may result in inaccurate cardiac output measurements or may damage the Argos monitor.



WARNING

Use of accessories, sensors, lines, and cables other than those specified in this User Guide may result in increased emission and/or decreased immunity to electrical field interference of the Argos monitor.



WARNING

Only an experienced practitioner should insert the arterial line.

**WARNING**

The transducer, 4-way stopcock, and connecting pressure tubing are single-use only and should never be reused.

**WARNING**

Observe institutional guidelines for disposal of biohazard waste after use of transducer, 4-way stopcock, and connected pressure tubing.

**WARNING**

The Navigation section of this manual is intended solely to familiarize users with the Argos monitor. Do not operate the Argos monitor until the user has read Chapter 8 and pertinent warnings and cautions.

**WARNING**

The Argos monitor is intended only to supplement patient assessment, and must *only* be used in conjunction with a bedside patient monitor.

**CAUTION**

Do not expose the Argos monitor to extreme temperatures.

**WARNING**

Use of the Argos monitor is restricted to one patient at a time.

**CAUTION**

The Argos Monitor is a precision monitoring device and should not be subject to excessive mechanical shock that may affect its structural integrity. Do not drop the monitor when handling, and do not tip over, or slam, the roll stand into a stationary object when the monitor is attached.

2.1 Device Labels



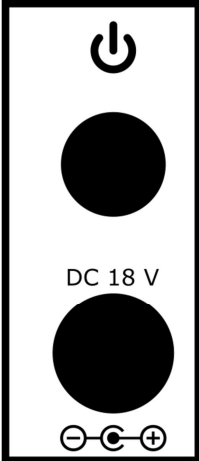
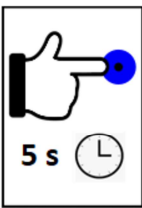

Image	Label	Description
	Company logo label	Company logo
	Product ID label	Product ID
	Power label	Power input
		Power switch prompt (Hold for 5 seconds)
		Power switch
<p>DC 18 V</p>		Power specification
		Power cable port

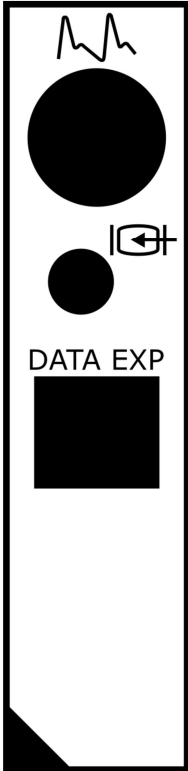
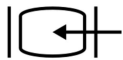

Image	Label	Description
	Data I/O label	<p>BP Transducer Input</p> <p>External monitor input</p> <p>Data I/O</p>
		Bedside patient monitor line-in
		Transducer line-in
<p>DATA EXP</p>		Data export ports

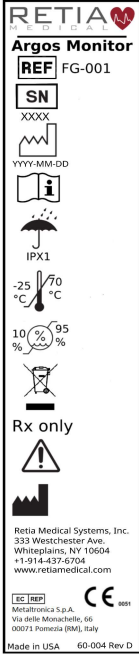







Image	Label	Description
	<p>UDI, Caution, and Company Contact label</p>	<p>Caution and Company Contact</p>
		<p>Part Number</p>
		<p>Serial Number</p>
		<p>Date of Manufacture</p>
	<p>Caution and Company Contact label (cont'd)</p>	<p>Read Operators Manual</p>
		<p>IP rating</p>
		<p>Temperature limits</p>
		<p>Humidity limits (non-condensing)</p>





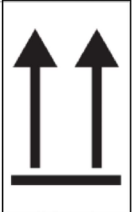

Image	Label	Description
		WEEE
Rx only		Prescription Use Only
		Caution
		Manufacturer
 <p> CONFORMS TO AAMI STD ES60601-1 IEC STD 60601-1 IEC STD 60601-1-6 IEC STD 62304 IEC STD 60601-2-34 CERTIFIED TO CSA STD C22.2 # 60601-1 </p>	ETL label	Lists standards to which Argos monitor complies

Table 2: Device Labels Power Supply

	Power supply label	Arrows indicate correct placement of power supply on pole mount
---	--------------------	---

 **WARNING**
Do not use the Argos monitor if it is damaged. Please contact a representative to report this to Retia Medical.

 **WARNING**
Do not use damaged system components.

2.2 Shipping Label

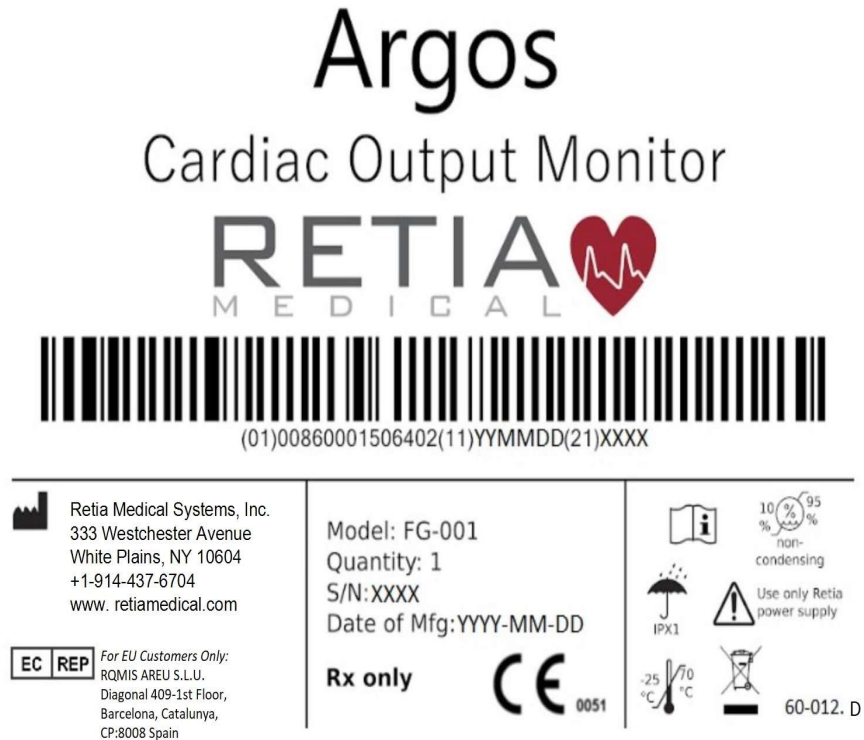

Fig. 2-1: Device Shipping Label

2.3 Standards Compliance

Applied Part Type	1x Type CF defibrillation-proof
Equipment class	Class II
Electrical Protection Class	IEC Class I
Ingress Protection Class	IPX1
IEC Standards	IEC 60601-1:2005+AMD1:2012
	IEC 60601-1-2:2014
	IEC 60601-2-34:2011*
	IEC 60601-1-8: 2011 IEC 62366-1:2015
Packaging standard	ISTA 2A

Table 3: Standards compliance

**Not including the section (208.6) on alarms. All alarms are governed by IEC 60601-1-8.*

3 Initial Setup

3.1 Mounting the Argos



WARNING

Do not attempt to use the Argos monitor if it is not fastened to a stand.



WARNING

During use, the Argos monitor should *never* be placed flat on a surface or balanced on a tabletop or other surface.

The Argos Cardiac Output Monitor is designed to be operated while fastened to a stand – for example, a standard pole mount or table stand. It complies with 75mm square screw patterns and 100mm square screw patterns which require M4 screws that extend 7-7.5mm into the monitor, not including the thickness of the VESA mounting plate. Retia recommends 10mm M4 screws for a 2.5mm thick mounting plate and 8mm M4 screws for a 1mm thick mounting plate. (For particular mounting solutions, please contact Retia Medical at 914-437-6704 , or at info@retiamedical.com.)

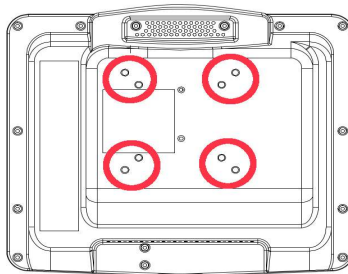

Fig. 3-1: Rear view, showing mount holes

When using the Argos monitor with a pole mount, the AC supply **must** be positioned so that the arrows on the label on the power supply are pointing upward, as shown below.

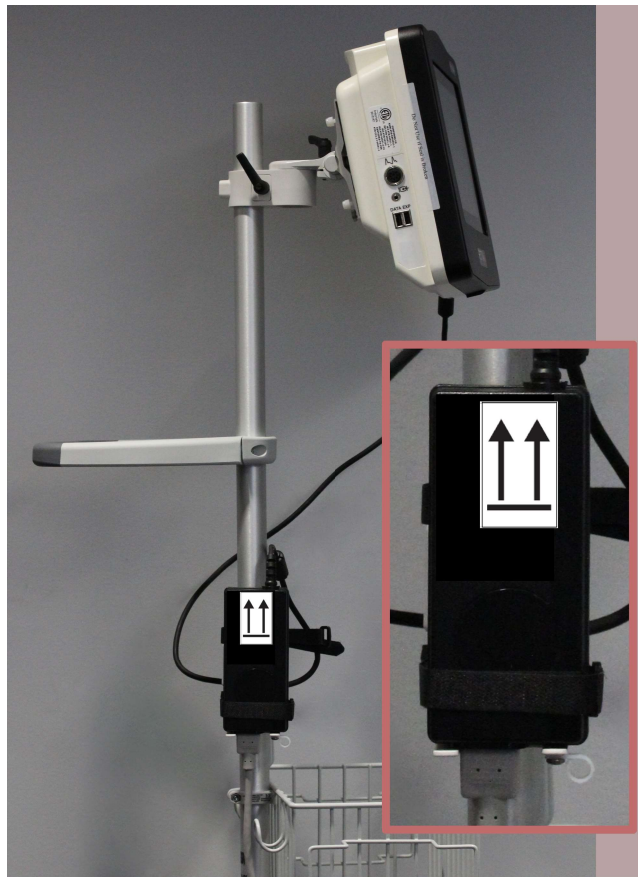

Fig. 3-2: Power supply shown mounted correctly, with arrows pointing upward



WARNING

The Argos monitor and power adapters must be positioned in an upright position to ensure IPX1 ingress protection.



WARNING

Do not position the external power supply in such a fashion that it is difficult to unplug the mains cord in case an emergency requires the monitor to be unplugged.



WARNING

The Argos monitor must be securely mounted. Ensure all cords and cables are placed so they pose no risk of injury to patients, users, or equipment.



WARNING

Ensure there is sufficient room for cables and transducer or monitor lines.



WARNING

To avoid potential fire hazard, if using a pole mount, make sure the power supply is placed on the pole so that the arrows on the label are pointing upward.



WARNING

Do not operate the Argos monitor outside operating specifications for temperature, humidity, and air pressure (see Section 8.1, Table 8-3). Ensure the device is within operating specifications before use.



WARNING

Ensure there is adequate space around the unit to allow for proper ventilation.



WARNING

Explosion hazard! Do not use the Argos monitor in the presence of any flammable anesthetic mixture with air or with oxygen or nitrous oxide.



WARNING

The Argos monitor is intended solely for use with a radial or femoral arterial catheter. *Do not* attempt to use it with any other kind of patient connection.



CAUTION

Do not expose the Argos monitor to extreme temperatures.



CAUTION

Grasp the connector – not the cable – when connecting or disconnecting a cable or line.



CAUTION

Do not twist or bend the connectors.



WARNING

Do not place any foreign items (unapproved 60601-1 items) in any of the Argos monitor ports.



WARNING

Equipment that generates high energy, high frequency electromagnetic radiation should not be used in close proximity to this monitor or any other patient monitoring equipment.

**WARNING**

Do not position IEC/EN 60950 equipment, including printers, any closer than 1.5 meters to the patient's bed while the Argos is in use.

**CAUTION**

Since BP waveforms may be affected by the use of electrosurgical units, distance electrocautery equipment and cables from the Argos monitor and plug the power cords into separate AC circuits. Should signal quality problems persist, call Retia Medical for assistance.

**CAUTION**

Regularly inspect all cables for defects. Never coil cables tightly while using, or when storing.

**CAUTION**

If any electrolytic solution such as NaCl, Lactated Ringers, is allowed to contact the cable connectors while connected to the Argos monitor, and the monitor is turned on, the excitation voltage may cause electrolytic corrosion and rapid degradation of the electrical contacts. Therefore, do not allow electrolytic solutions to contact the cable connectors.

**CAUTION**

Portable and mobile RF communication equipment can potentially affect all electronic medical equipment, including the Argos monitor. Guidance on maintaining appropriate separation between communications equipment and the Argos monitor is provided in the Manufacturer's Declaration of Conformity Electronic Emissions and Immunity on page 1.

**CAUTION**

The sole function of the Argos monitor's data export ports is to export data. Do not attempt to use the data export ports for any other purpose.

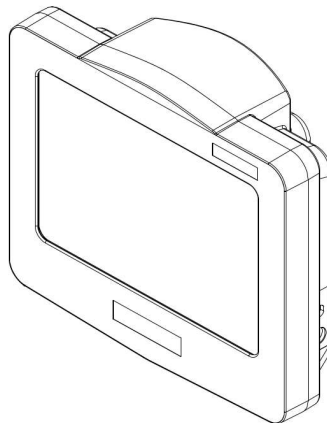

Fig. 3-3: View from top right, showing power input and power switch

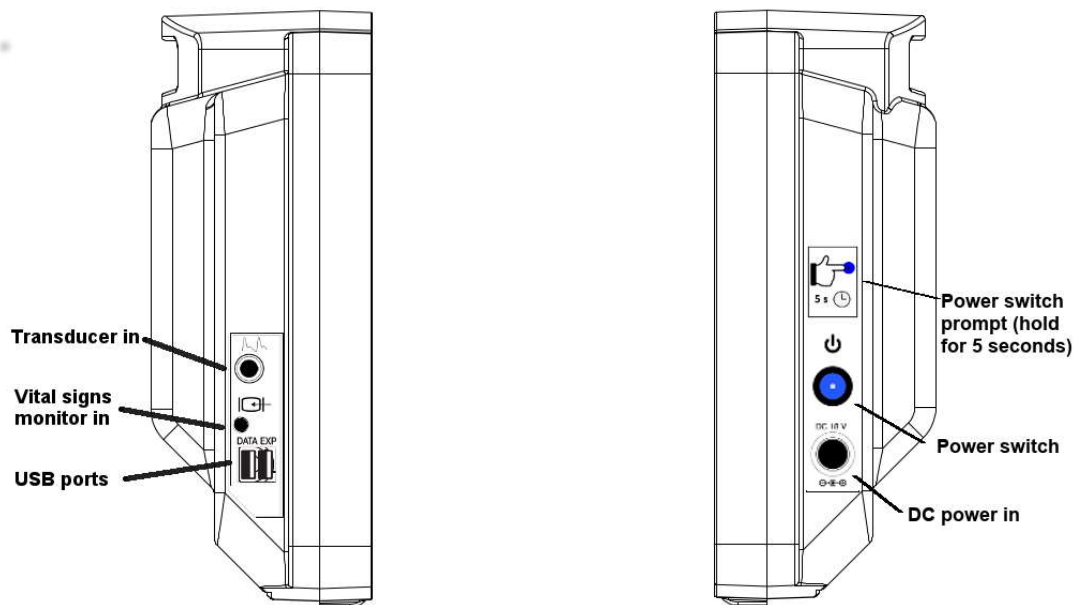

Fig. 3-4: Left and right side views

Before use, ensure the Argos Monitor has not been tampered with. If signs of tampering are present, contact Retia Medical for assistance.



WARNING

Do NOT use the Argos monitor if signs of tampering are present. Contact a Retia Medical representative.



WARNING

Do not attempt to connect a power supply to the monitor that has not been approved for use by Retia Medical.



WARNING

To avoid the risk of electric shock, this equipment must only be connected to a supply mains with protective earth.

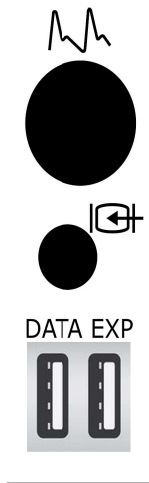

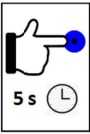
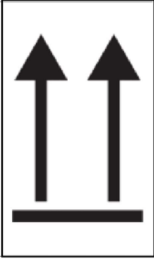



Fig. 3-5: Left side port panel, showing inputs for transducer (top) and monitor line-in (middle)

	<p>Fig. 3-6: Right side power panel, showing power cable input and power switch</p>
	<p>Fig. 3-7: Power label instructions</p>
	<p>Fig. 3-8: AC adapter label indicating proper orientation on pole stand</p>

 **WARNING**
Do not use extension cords or multiple socket devices to connect the power adapter.

 **WARNING**
Do not connect the Argos monitor to a patient monitor using an AC or pulsed DC pressure transducer excitation voltages.

 **CAUTION**
The Argos monitor is intended for operation while plugged into an AC wall outlet. Although it will continue to function at full capacity on battery power alone, such as when an emergency power outage occurs, it is **not** designed for cordless use. In case of a power outage, use of the Argos monitor should be terminated as soon as feasible.

Plug the power cable into to a working AC power outlet. Connect the cable to the DC power in socket of the monitor.

 **WARNING**
The Argos *must* be used in conjunction with an approved bedside patient monitor.

**WARNING**

When using a transducer connected directly to the Argos monitor, make sure the transducer is leveled to the phlebostatic axis.

**WARNING**

Do not place any foreign items (unapproved 60601-1 items) in any of the Argos monitor ports.

The Argos must be connected either directly to a transducer from a radial or femoral artery catheter, or to a bedside patient monitor.

**WARNING**

Carefully inspect the radial or femoral arterial line before use.

**WARNING**

Do not use a transducer or catheter that is damaged or that has exposed electrical contacts.

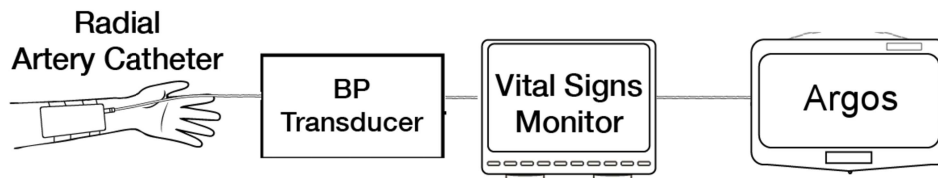

Fig. 3-9: Standard patient line, from transducer to monitor to Argos

The patient should be fitted with a radial or femoral arterial catheter.

If, as in Fig. 3-9 above, the transducer is connected to a bedside patient monitor, the Argos connects to a line from the monitor.

The Argos monitor is designed for use with a bedside patient monitor analog output with a range of 0-3V and a scale 1V=100mmHg.

**WARNING**

Before operating in conjunction with a bedside patient monitor, consult with a Retia Medical representative to ensure the monitor has compatible specifications.

**WARNING**

Do NOT use the Argos monitor in proximity to an MRI scanner.



CAUTION

Following exposure to defibrillation voltage, the Argos monitor recovers within 10 seconds.



WARNING

A hazard can exist if different alarm/alert presets are used for the same or similar equipment in any single area.



WARNING

Do not attempt to attach or connect a transducer, transducer line, monitor, or monitor line to the Argos monitor which has not been certified for use by Retia Medical.

If a transducer is connected directly to Argos, as in Fig. 3-10, another transducer must be connected to the bedside patient monitor, for example with a 4-way stopcock.



WARNING

If the Argos monitor is connected directly to a transducer, the patient must also be simultaneously connected to the bedside patient monitor with another transducer via a 4-way stopcock.

Detailed setup instructions are at §5.4.1, page 52.

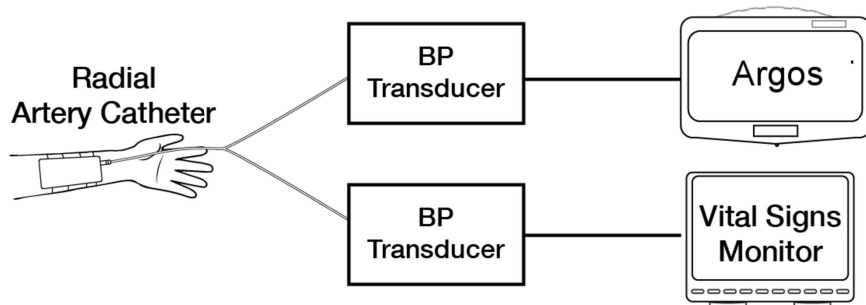

Fig. 3-10: Transducers connected to Argos and bedside patient monitor



WARNING

Shock or fire hazard! Do not immerse the Argos monitor or cables in any liquid solution. Do not allow any fluids to enter the instrument.



WARNING

Use of a damaged cable may result in inaccurate cardiac output measurements or may damage the Argos monitor.



WARNING

Use of accessories, sensors, lines, and cables other than those specified in this User Guide may result in increased emission and/or decreased immunity to electrical field interference of the Argos monitor.



WARNING

Only an experienced practitioner should insert the arterial line.



WARNING

The transducer, 4-way stopcock, and connected pressure tubing are single-use only and should never be reused.



WARNING

Observe institutional guidelines for disposal of biohazard waste after use of transducer, 4-way stopcock, and connected pressure tubing.

If the user is connecting a transducer directly to the Argos monitor, use only the transducer specified by Retia Medical.

To power on, press and hold the power button for 5 seconds. The indicator on the power button will light up blue, signaling that the device has been switched on.

4 Basic Navigation



WARNING

The Navigation section of this manual is intended solely to familiarize users with the Argos monitor. Do not operate the Argos monitor until the user has read Chapter 8 and pertinent warnings and cautions.

4.1 Overview

The Argos Cardiac Output Monitor is lightweight, portable, and simple to operate, with a touchscreen interface providing quickness, ease of use, and maximum user accuracy.

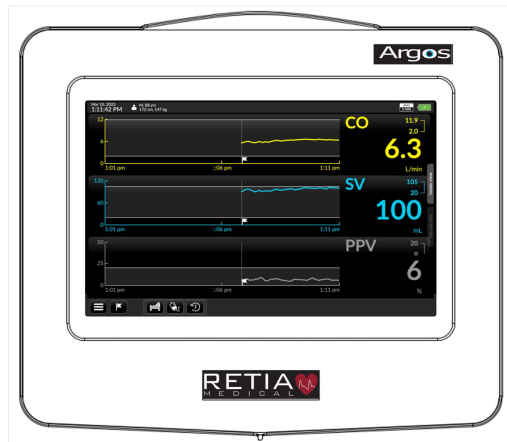

Fig. 4-1: Front view of Argos monitor



WARNING

The Argos monitor is intended solely for use by qualified clinicians who have been trained in its use.



WARNING

The Argos monitor is intended only to supplement patient assessment, and must *only* be used in conjunction with a bedside patient monitor.

4.2 The Touchscreen Interface

Operate the Argos monitor just as a user would a smartphone or tablet: with a fingertip, simply tap the screen to make a selection, choose from a list, enter numeric or textual data, or verify before proceeding to the next step.

4.3 Entering Patient Data



WARNING

Use of the Argos monitor is restricted to one patient at a time.



WARNING

Once patient data has been entered, it *cannot* be edited or changed. Therefore, if the patient demographic information is incorrect or needs to be changed for any reason, it is necessary to start a new session.

Press the power button for 5 seconds to switch on the Argos monitor. After bootup, the user is presented with the Add Patient Data screen.

Fig. 4-2: On power up the Add Patient Data screen appears

Please enter the Patient ID, birth gender and age. Choose metric or imperial units by tapping the corresponding box for weight and height. Here, bright white letters against a black background indicate metric units are selected:

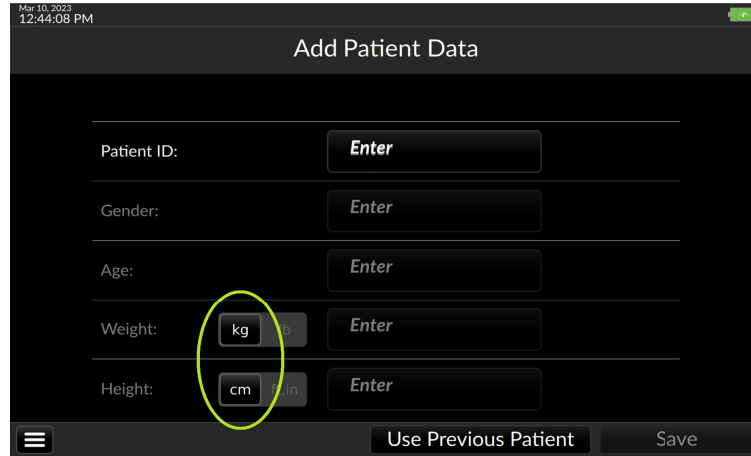

Fig. 4-4: Units buttons

Now the user may enter the patient's demographic information.

- *If the user has obtained Electronic Medical Records (EMR) functionality, make sure the correct patient ID has been entered as indicated in §5.5 so that the patient is correctly registered in the Electronic Medical Records (EMR) database.*

Begin by pressing the box beside the field labeled Patient ID.

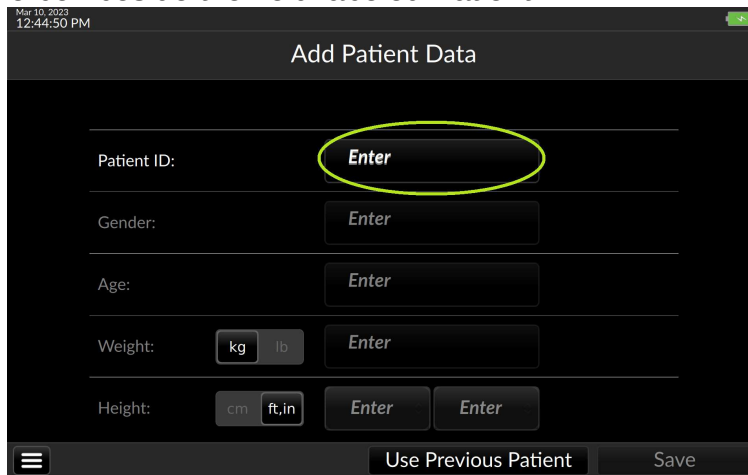

Fig. 4-5: Touch a field to bring up the virtual keyboard

A virtual alphanumeric keyboard appears.

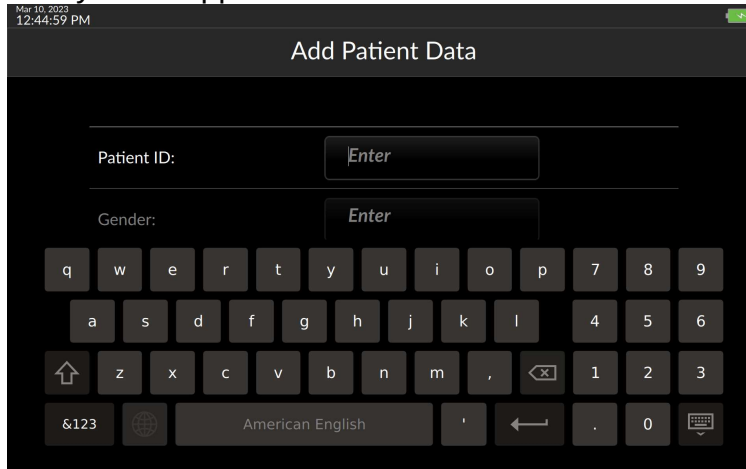

Fig. 4-6: Setup screen ready for Patient ID entry

Enter the patient ID, then press Return to dismiss the keyboard.

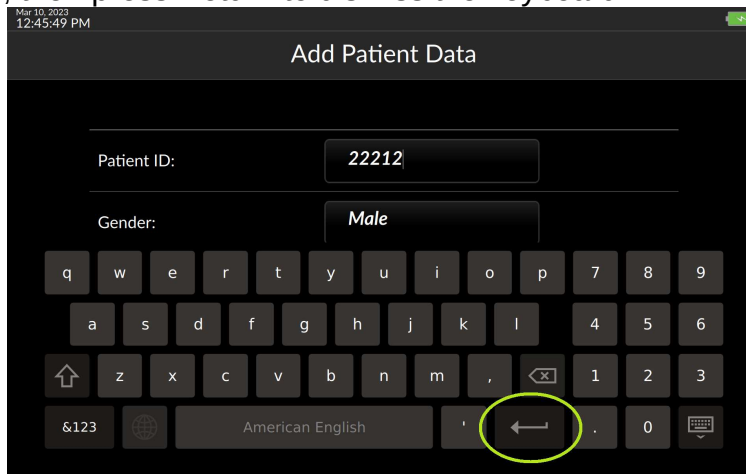

Fig. 4-7: Touch the Enter key to register the value and proceed

Proceed by selecting the correct value from the Gender drop down. Touching inside the remaining entry fields calls up a numeric keypad.

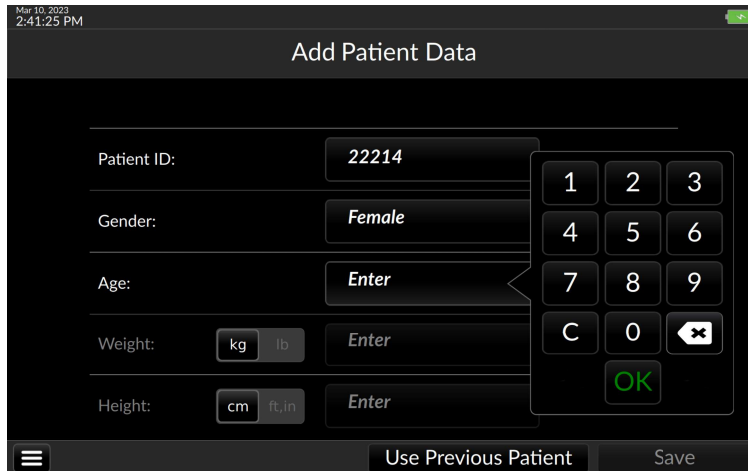

Fig. 4-8: Use the keypad to enter demographic information

Ensure all patient demographic data is correct as these values will be used to estimate body surface area and will affect the indexed values. Press Save to register the patient's demographic information in the Argos.

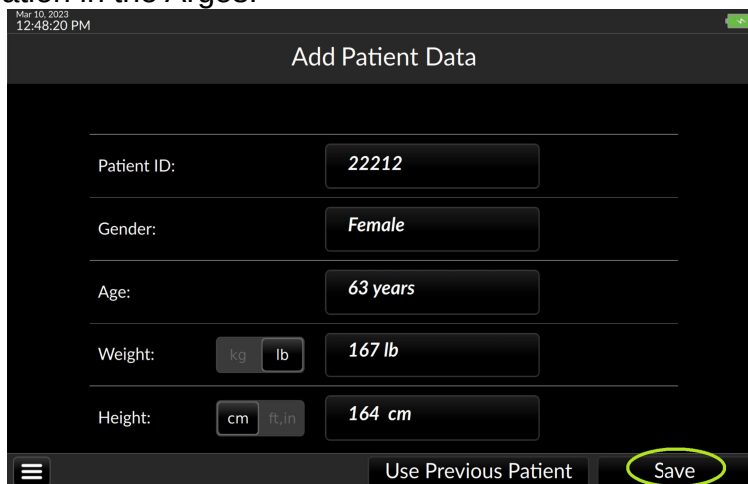

Fig. 4-9: Press Save to continue to BP Source selection

The user is ready to select the blood pressure source.

4.4 Select Blood Pressure Source

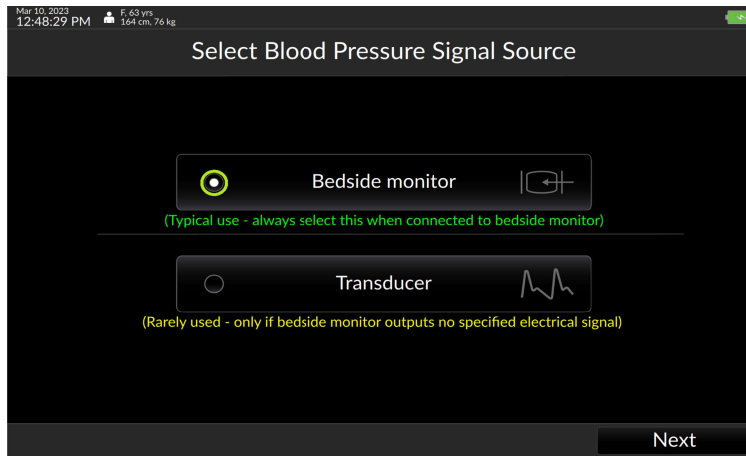

Fig. 4-10: Choose whether patient is connected via a transducer or bedside monitor

Select *Transducer* only if the Argos monitor is connected directly to a transducer. Select *Bedside Monitor* if the Argos monitor is connected to a bedside patient monitor (normally used). Touch *Next* to proceed.

- ⤷ Note the patient demographic information beside the small figure in white on the top status bar of the screen. Be sure to use it to check the information is correct before proceeding with monitoring.



Fig. 4-11: Verify patient demographic information is correct before proceeding

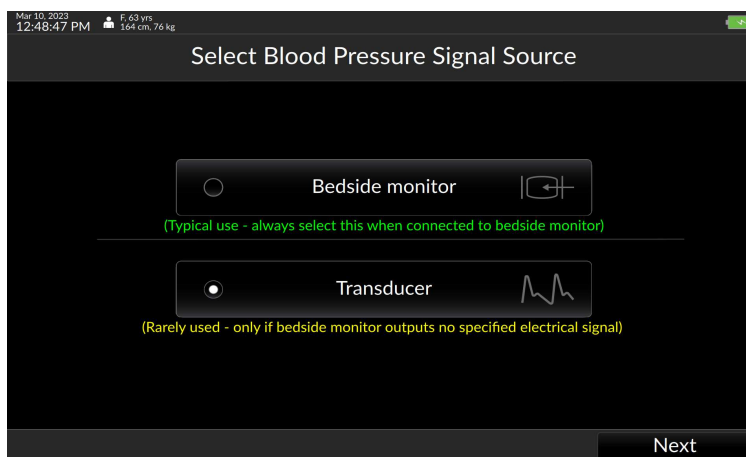

Fig. 4-12: Transducer shown selected; press Next to continue

If *Bedside monitor* is selected, pressing *Next* will initiate monitoring.

If the user has selected *Transducer* as BP source, the transducer must be zeroed before proceeding.

4.5 Zero Transducer



WARNING

Failing to zero the transducer correctly may lead to incorrect monitoring results.

The Zero Transducer screen appears.

- 1) Open the transducer to atmosphere by turning the stopcock to the *Off* position.
- 2) Press *Zero transducer*.

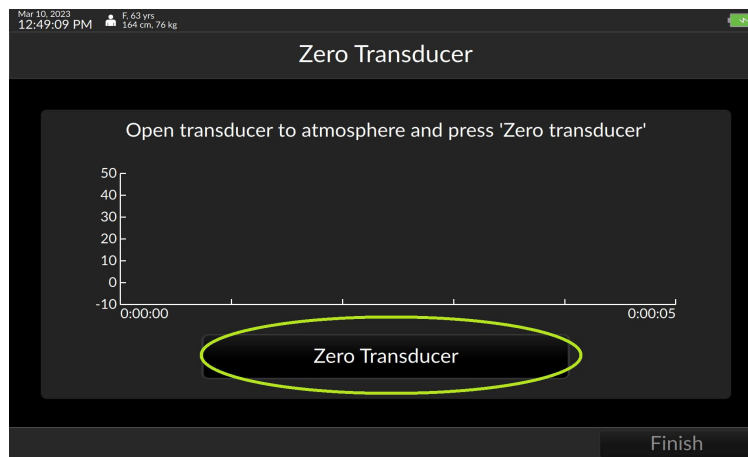

Fig. 4-13: Ready to zero transducer

- 3) The screen returns “Transducer zeroed.”
- 4) Return the stopcock to *Patient*. Press *Finish* to initiate monitoring. Please verify the alert functionality whenever the device is turned on, immediately after beginning a new monitoring session. The procedure to verify alert functionality is described in Appendix 8.12, p. 153.

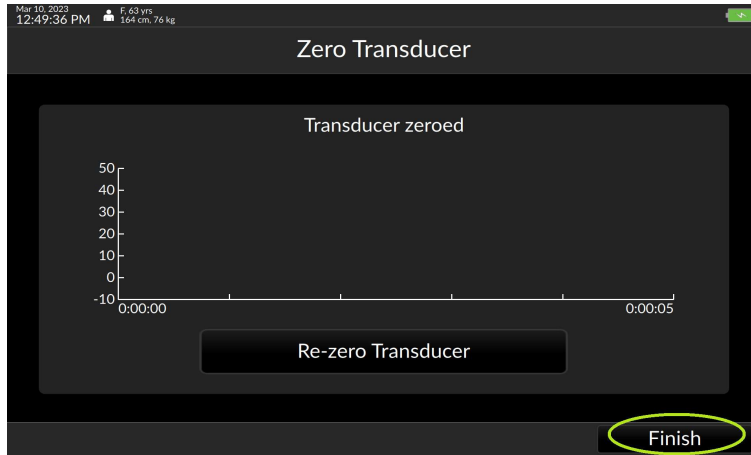

Fig. 4-14: Press finish to begin patient monitoring

4.6 The Trend Screen

At startup, if the Argos monitor is starting a new patient, it shows the default trend parameters and uses the default settings. If a previous patient is selected, the previous session's selected parameters and display settings are used.

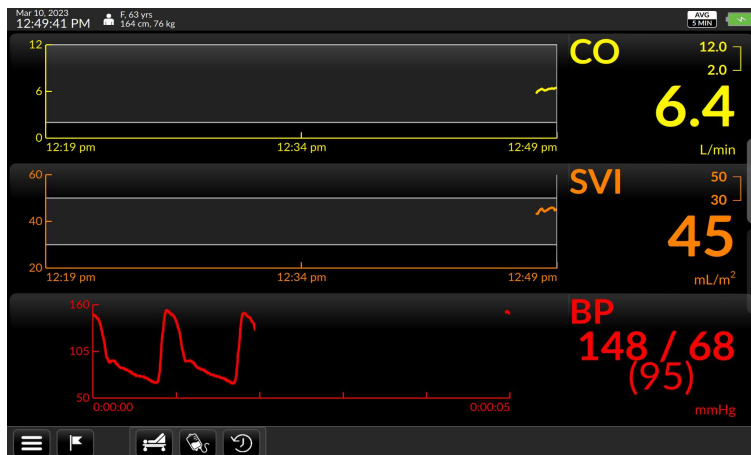

Fig. 4-15: The default trends

To the right of each trend is the Parameter Label Field:

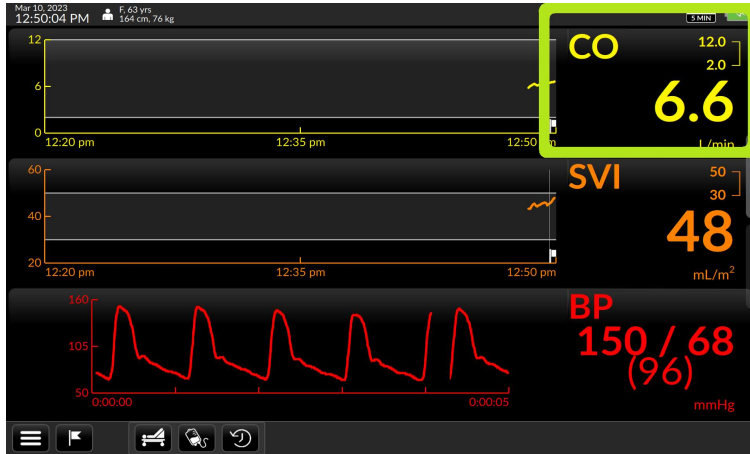

Fig. 4-16: Parameter label field shown highlighted

showing the parameter name at the top left corner, current numeric value prominently in the bottom right.



WARNING

The Argos monitor *does not* alarm upon detection of low CO. Such notifications are a function of the bedside patient monitor.

In the upper right, maximum and minimum limit values are displayed.



If the measured value exceeds either of these, a yellow box indicates an alert.

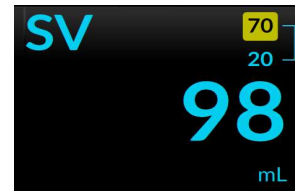

4.6.1 Selecting a different parameter

To change monitored parameters, for instance from Cardiac Output to MAP, start by pressing and quickly releasing the Parameter Label to call up Parameter Settings.

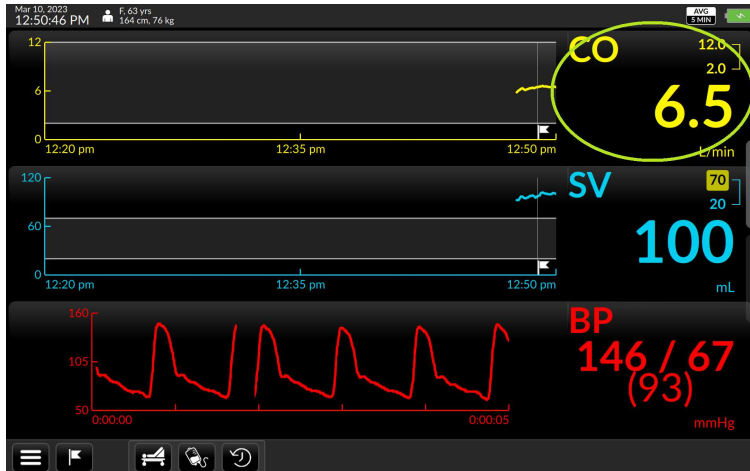

Fig. 4-17: To switch parameters, tap the parameter label

The Parameter Settings overlay appears. The Parameter Selection box is marked with a downturned triangle.

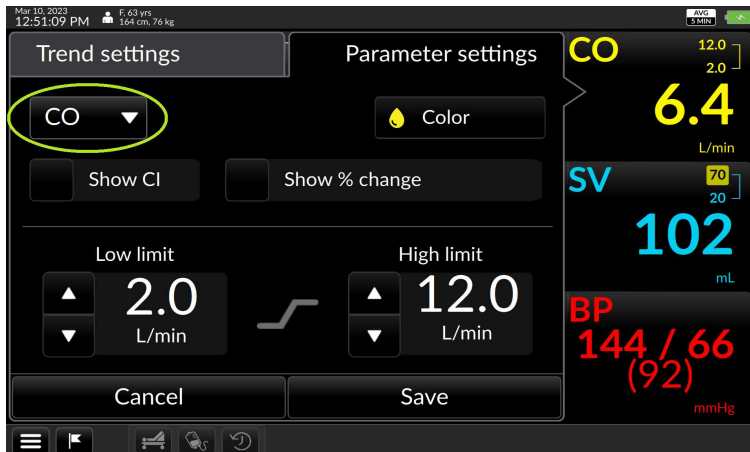

Fig. 4-18: Tap the label to choose a different trend

Press the selection box to open a dropdown list of parameters; scroll down to see more.

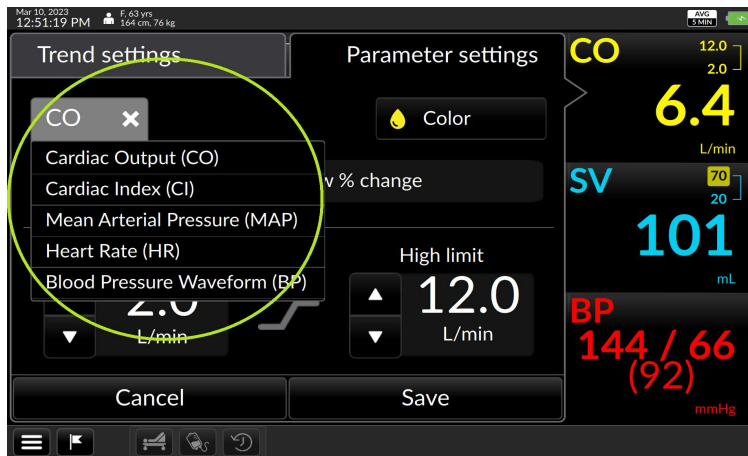

Fig. 4-19: The dropdown list of parameters

Press on the desired choice – in this case, Mean Arterial Pressure (MAP).

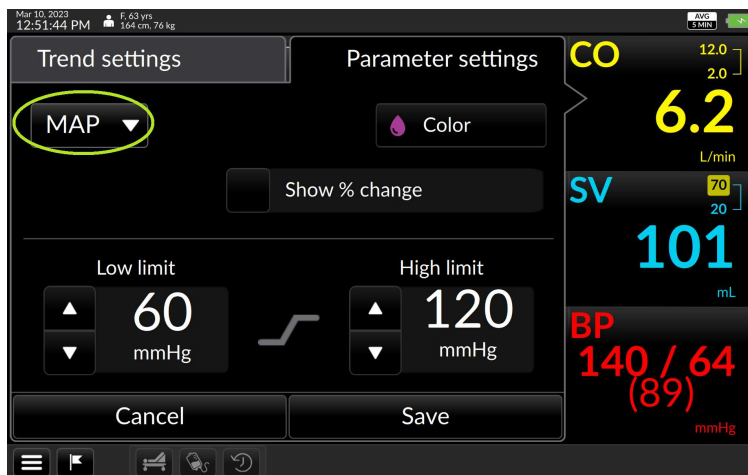

Fig. 4-20: MAP shown selected

Press Save to save the selection and return to the Trend screen.

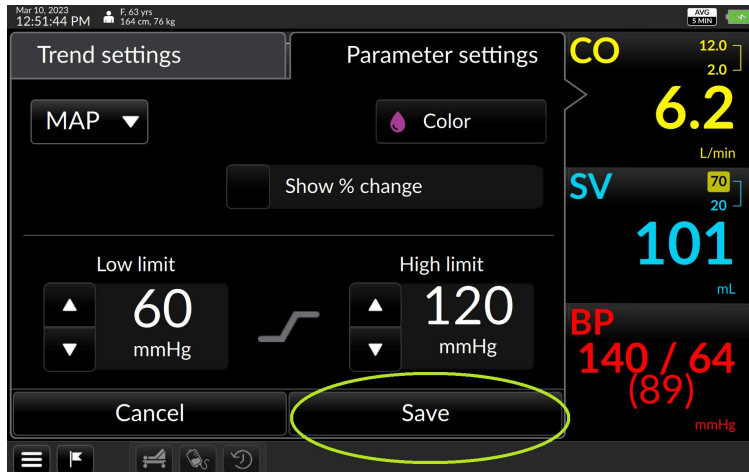

Fig. 4-21: Press Save to continue

The Trend screen returns with MAP displayed.

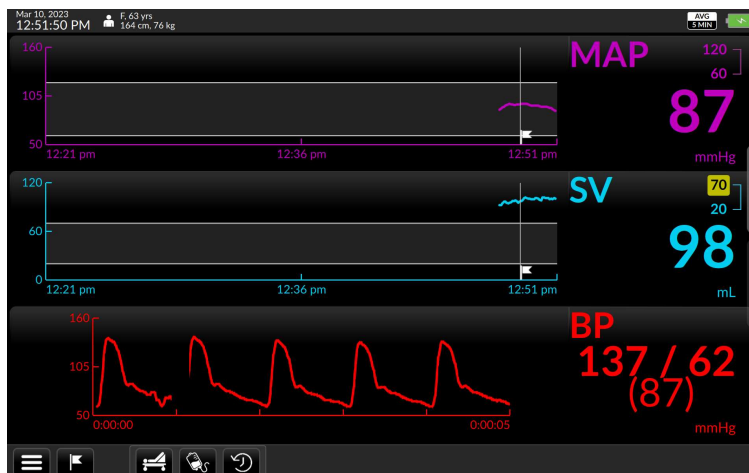

Fig. 4-22: MAP displays

4.6.2 Changing Trend Settings on the Trend Screen

The Trend Settings overlay offers choices for time scales, alert limits, colors, and additional values for selected parameters. (See §5.9.1, page 76 for more detailed information.)

Changing the scale of the trend coordinates:

The touchscreen allows for adjustment of position and scale of trends along both X- and Y-axes, and coordinate minimum and maximum values.

To move backward or forward in the time axis, touch the gray arrow pointing leftward (earlier) or to the right (later): slide a finger right to view earlier or left to view later until the desired timeframe comes into view.

To compress the scale of the time axis, place two fingers apart horizontally on a trend displayed on the touchscreen and move them toward one another in a pinching motion.

To expand the scale of the time axis, touch two fingertips together on a trend and spread them apart.

The default value is 10 minutes.

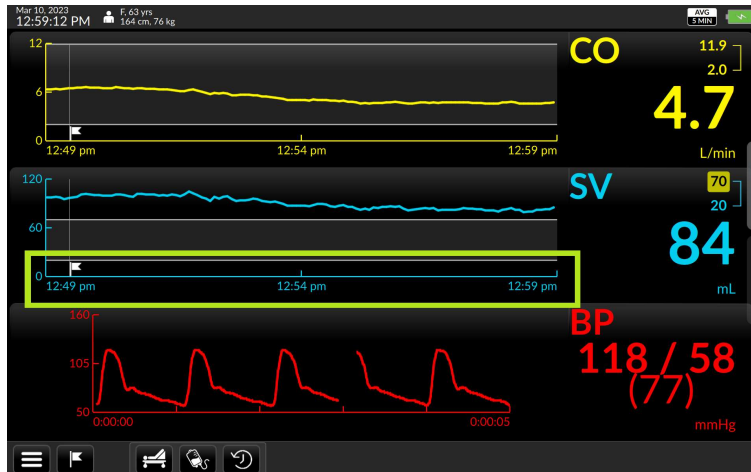

Fig. 4-23: The default interval is 10 minutes

To view details of the trend settings, press on the parameter value to bring up the trend settings screen.

The Time Scale selection box is labeled with the current value, along with a downturned triangle.

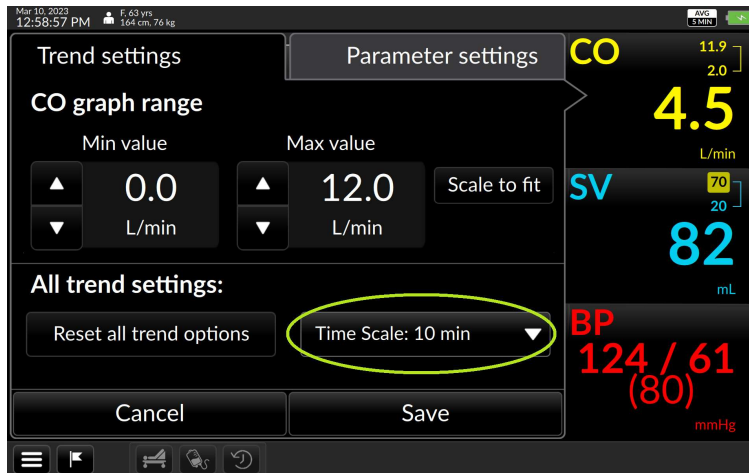

Fig. 4-24: The Time Scale selector

Touch anywhere inside it to access a range of values.

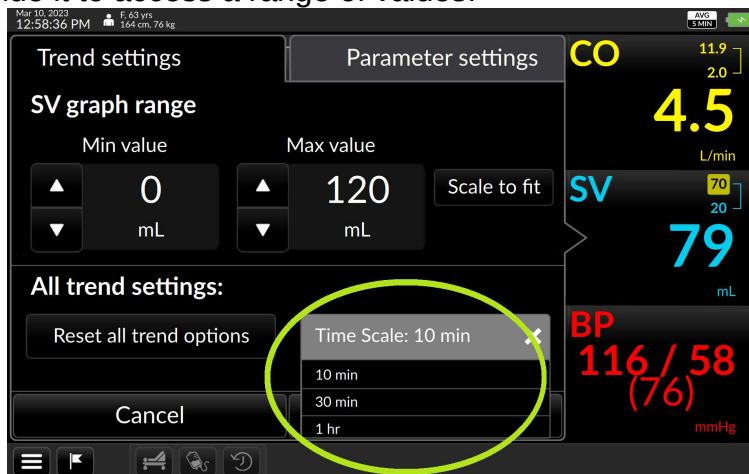

Fig. 4-25: Tapping the Time Scale box opens up a selection box

Choose the desired interval, then press Save to return to the Trend screen.

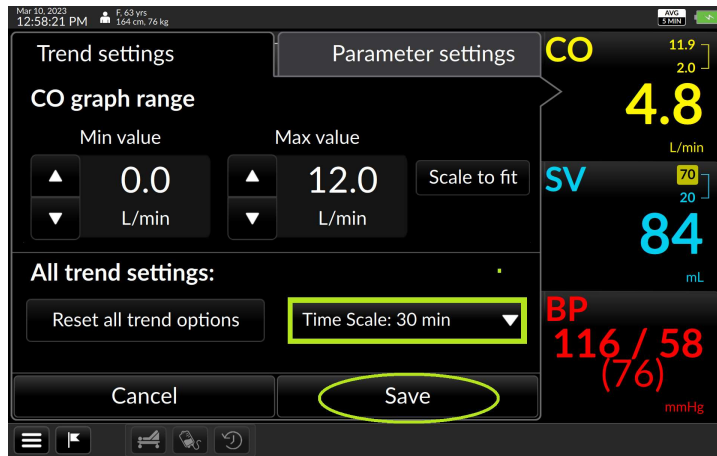

Fig. 4-26: Select the desired timescale, press Save to continue

All three trends are now scaled to the new time axis:

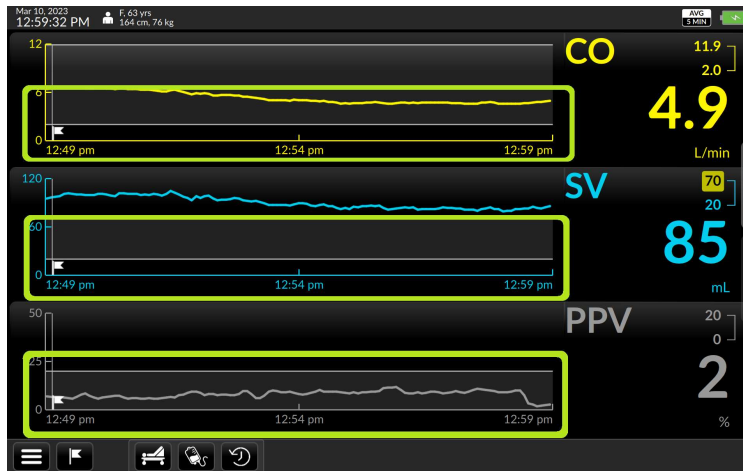

Fig. 4-27: Waveforms display in 30-minute intervals

4.7 End Session / Shut Down



WARNING

Only power off the Argos Monitor using the Shut Down function from the User Menu.
Never power off the monitor by pressing the power switch or unplugging the device.

To end patient monitoring, or to shut down the Argos monitor, touch the Menu icon button on the control bar located on the bottom left hand side of the screen.:

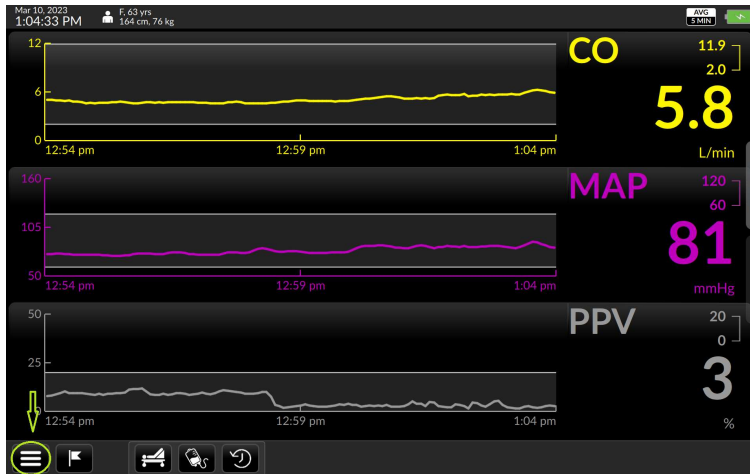

Fig. 4-28: Touch the Menu icon to activate the User Menu

The User Menu appears.

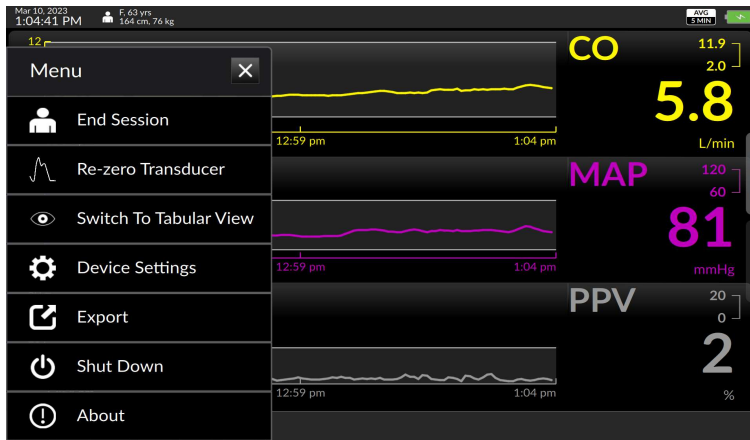

Fig. 4-29: The User Menu

To terminate the current session press *End Session*.

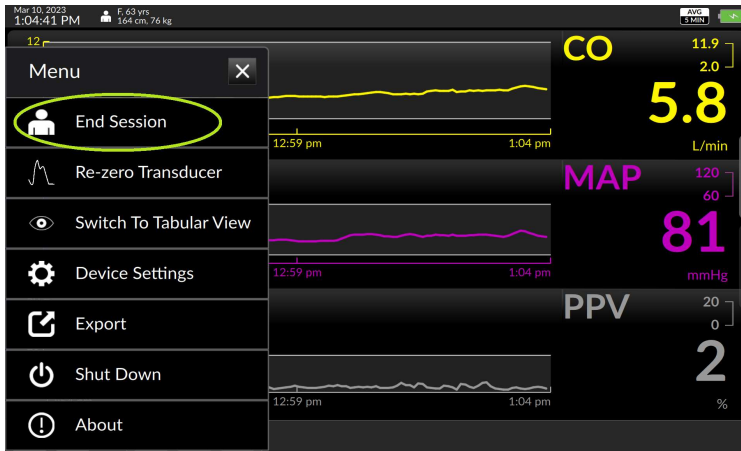

Fig. 4-30: Press *End Session* to end the current session and start a new one

A confirmation screen appears.

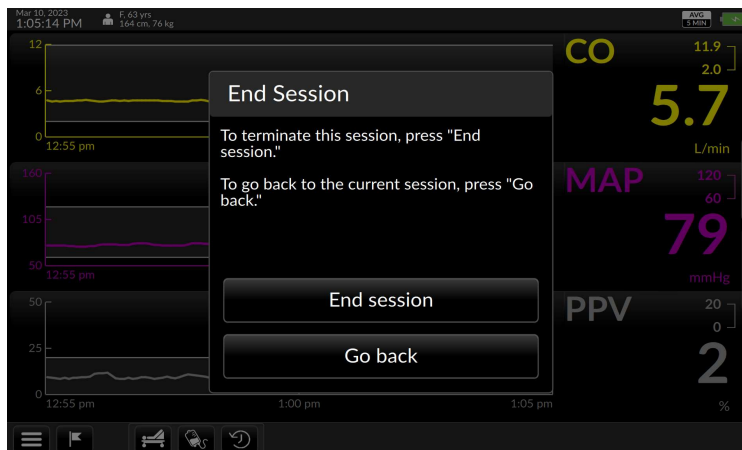

Fig. 4-31: Verify ending session

To confirm that the user wishes to end the current monitoring session, press *End Session*. The user will be taken to the Initial Patient Setup screen (see §5.5). If the user does NOT wish to terminate the session, press *Go back* and return to the current patient on Trend Screen.

4.7.1 Shut down



WARNING

Only power off the Argos Monitor using the Shut Down function from the User Menu.
Never power off the monitor by pressing the power switch or unplugging the device.

To shut down the Argos monitor, select *Shut Down* from the User menu:

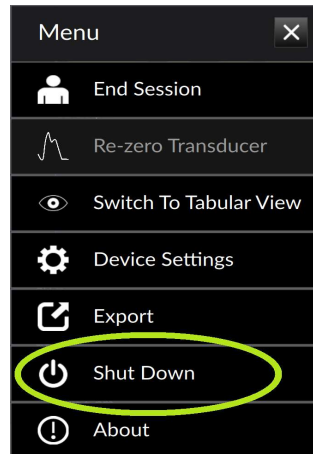

Fig. 4-32: Select Shut Down

A confirmation screen appears:

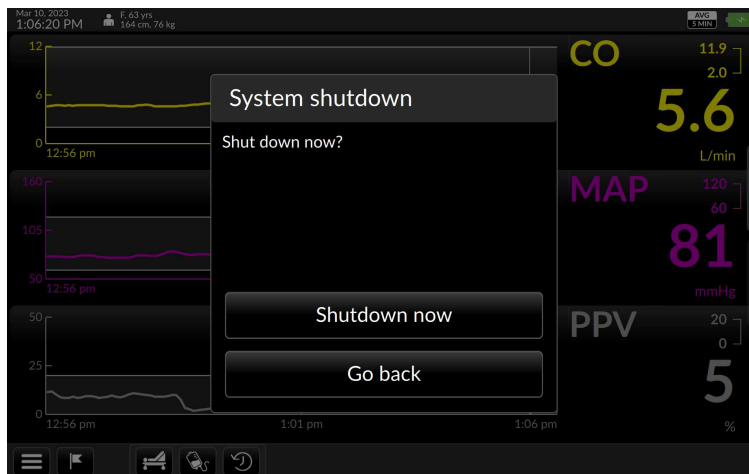



Fig. 4-33: Confirm Shutdown

To end the patient session and turn off the Argos monitor, press *Shutdown now*. Otherwise, to continue the current monitoring session, press *Go Back* to return to the Trend Screen.

5 Using the Argos Monitor

The Argos Cardiac Output Monitor provides quick access to blood pressure monitoring and derived parameters through a rapidly configurable touchscreen interface. The next section introduces the user to the basic screens; following chapters offer step-by-step instructions for using the Argos. Please take care to observe **Cautions** and **Warnings** (boxed text marked by an exclamation point set off in a yellow triangle) and helpful notes (☺).

	WARNING The Argos monitor <i>does not</i> alarm upon detection of low MAP. Such notifications are a function of the bedside patient monitor.
---	--

	WARNING The Argos monitor is intended only to supplement patient assessment, and must <i>only</i> be used in conjunction with a bedside patient monitor.
---	--

5.1 Guide to screens

The Argos is operated by entering information and accessing options through a touchscreen interface. Use a fingertip to select data and quickly move through screens.

The interface has three primary modes: Setup, Trend Screen, and Tabular View.

Setup, used to enter patient information at the beginning of each new session.

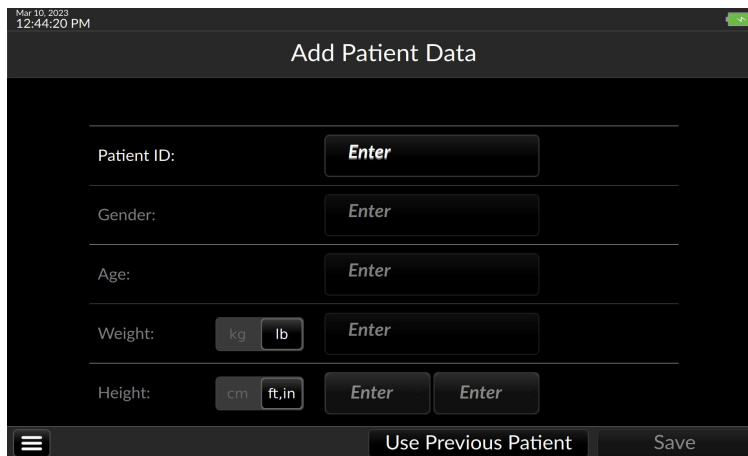

Fig. 5-1: The Add Patient Data screen

The **Trend Screen**, showing three trends, each identified by the parameter label field, or label, to the right.

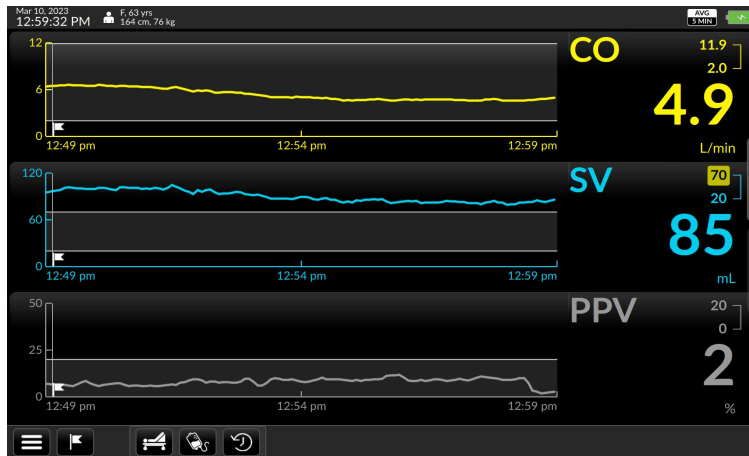

Fig. 5-2: The Trend Screen

All three trends are user-selectable. Prior monitoring session trends can be accessed via fingertip control and coordinates scaled across either axis. The parameter label field can show quantitative indices, values or changes, and allows adjustment of alert limits. Examples below offer a closer look:

Each label shows the parameter name, alert limits, and, in larger characters, current numeric value.



Optionally, a label can show a percentage change (see §5.8.2. page 67) since the last event created, or from monitoring initiation, if no event has been created.

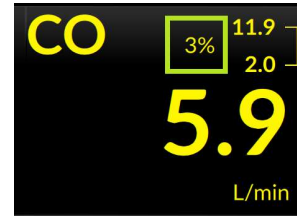

Some parameters can be configured to show an associated index or value.

Here, stroke volume (SV) displays below the Stroke Volume Index (SVI) label.



The numbers connected by the brace in the upper right corner are high and low alert limits, which are user-configurable.

Should the value of the parameter exceed either limit, the limit will show against a yellow background for as long as the value is beyond the selected threshold.



Touching the parameter label brings up the **Parameter Settings** overlay. Here the user can select a new parameter, or add, remove, or change the way a parameter is displayed, including colors and alert thresholds.

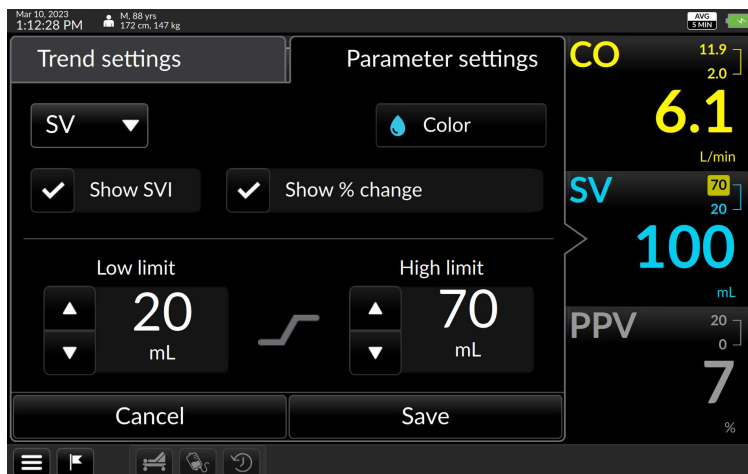

Fig. 5-3: Parameter settings

Touching the trend display summons **Trend Settings**, which allows for adjusting the trend graph, both the trend (Y-axis) value, and the time coordinate (X-axis).

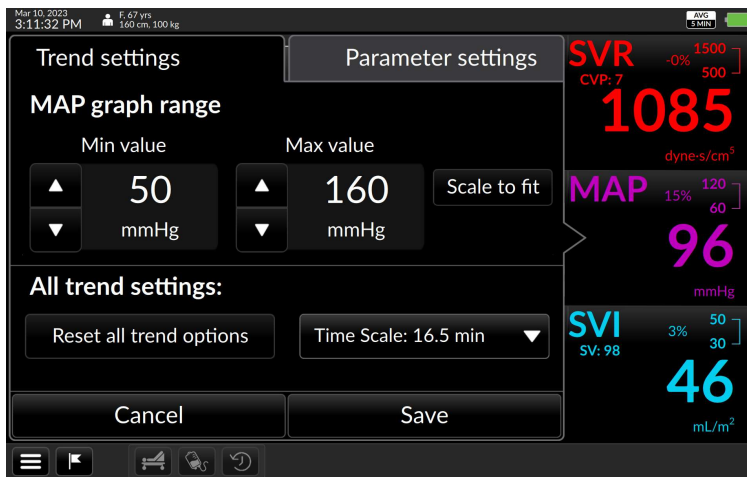

Fig. 5-4: Trend settings

The **Tabular View** screen displays continuously measured values in intervals of 15 minutes, 30 minutes, 1 hour or 2 hours.

Time	Mar 13, Mon 9:24 AM	Mar 11, Sat 5:30 PM	Mar 11, Sat 5:45 PM	Mar 11, Sat 6:00 PM	Mar 11, Sat 6:15 PM	Mar 11, Sat 6:30 PM	Mar 11, Sat 6:45 PM
CO L/min	5.6	4.7	6.4	5.3	5.0	4.6	6.5
CI L/min/m ²	2.6	2.2	3.0	2.5	2.3	2.2	3.0
SV mL	96	86	98	94	85	83	100
SVI mL/m ²	45	40	46	44	40	39	47
SVR dyne-s/cm ²	1090	1122	1077	1074	1195	1151	1086
SVRI dyne-s·m ² /cm ⁵	2325	2394	2297	2290	2549	2455	2316
PPV %	2	10	7	5	3	9	7

Fig. 5-5: Tabular view

Access the Tabular view screen in one of three ways:

- 1) Touch the “Tabular View” tab located on the right side of the Trend Screen

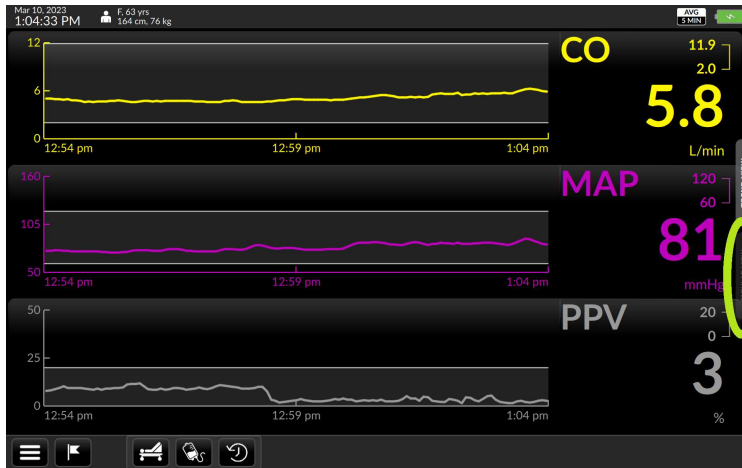

Fig. 5-6: The Tabular View tab

2) Drag upward with one finger from the bottom of the Trend Screen

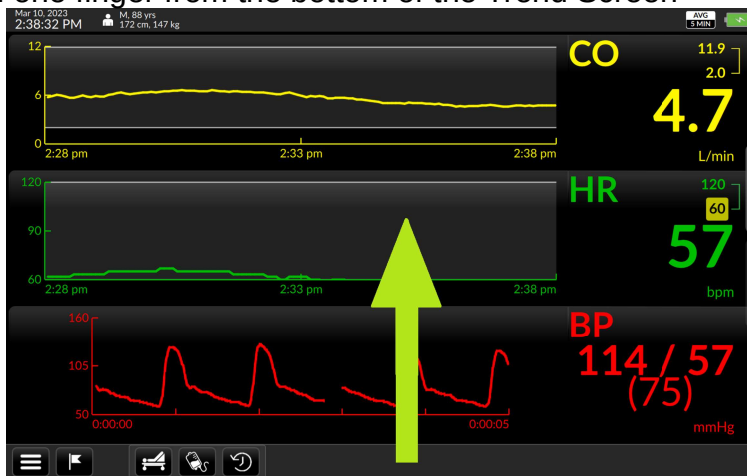

Fig. 5-7: Use a fingertip to drag upward from the bottom of the Trend screen

3) Tap the User Menu navigation icon at the bottom left of the screen (see §5.11.2, p. 89) and select "Switch to Tabular View"

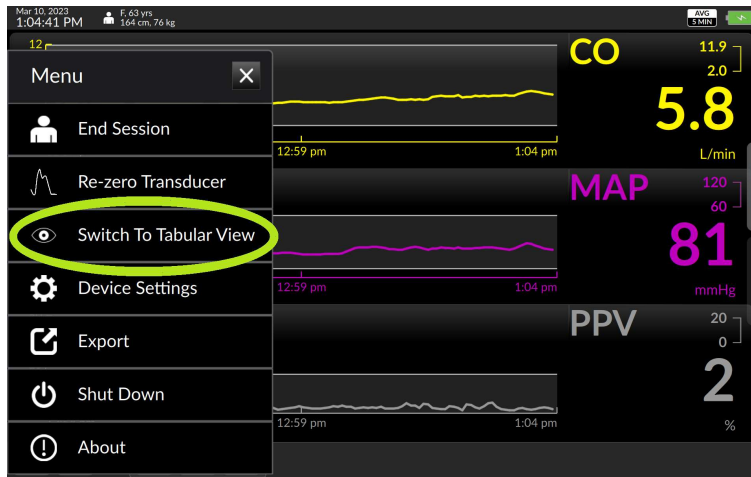

Fig. 5-8: Touch Switch to Tabular view on the user menu

To return to the Trend Screen from Tabular View:

- 1) Touch the “Trend View” tab located on the right side of the Tabular screen

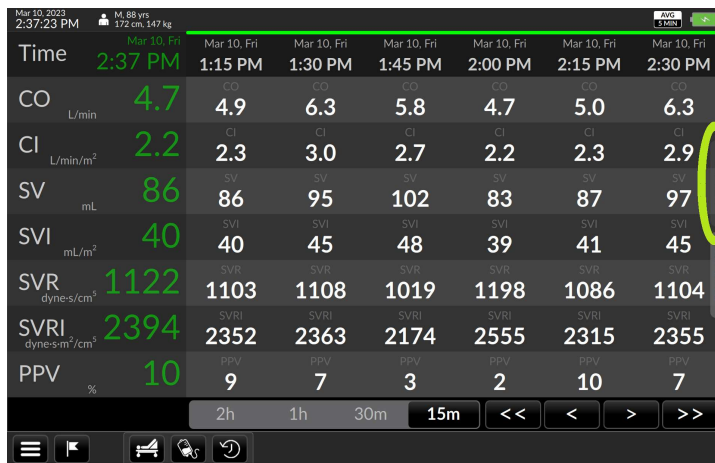

Fig. 5-9: The Trend View tab

- Or 2) drag downward with one finger from the top of the Tabular View screen

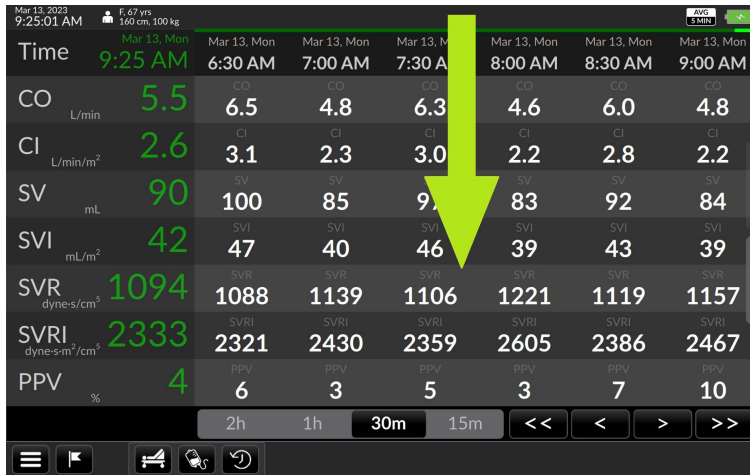

Fig. 5-10: Use a fingertip to drag downward from the top of the Tabular View

Or 3) tap the User Menu navigation icon at the bottom left of the screen (see §5.11.2, p. 89) and select “Switch to Trend View”

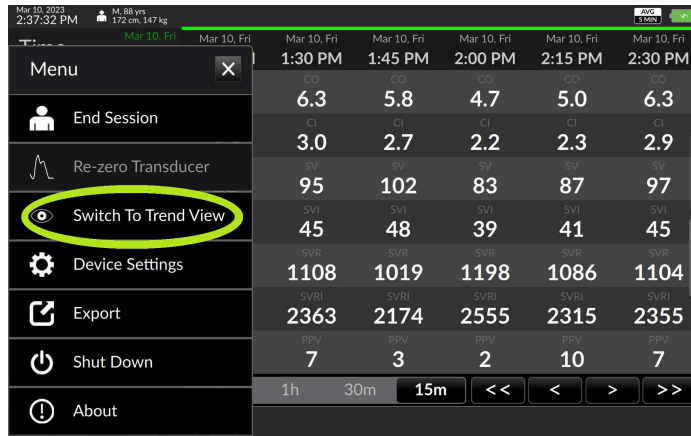

Fig. 5-11: Touch Switch to Trend View on the user menu

5.2 Trend Scrubbing

Dragging a fingertip along a waveform activates the “scrubbing” function, which pops up the numeric value of the trend at the particular moment. Place your finger on the trend plot to initiate this:



Fig. 5-12: Trend values shown on trends

5.3 The Control Bar & Status Bar

A number of options and settings can be accessed via the **status bar** and the **control bar** which is always visible at the top and bottom of the display.

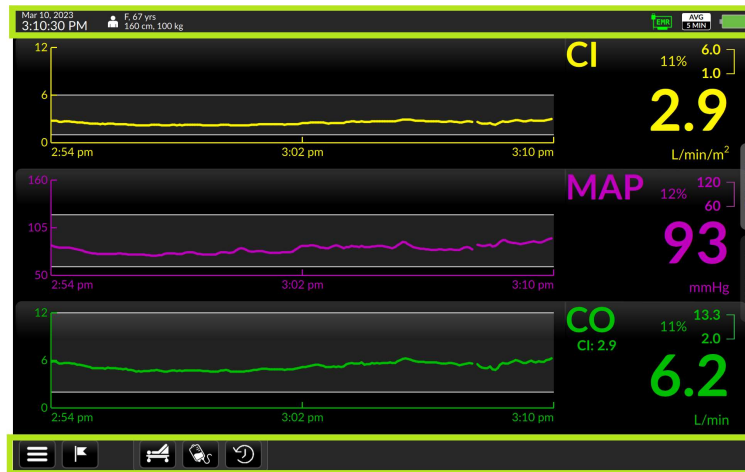

Fig. 5-13: Status bar and control bar shown highlighted

The control bar contains the menu icon, allowing access to important functions. The Control Bar selection offers access to Event marking and Dynamic Assessment functionality. Dynamic Assessment functionality includes Passive Leg Raise (PLR) and fluid bolus challenge and the Dynamic Assessment History.

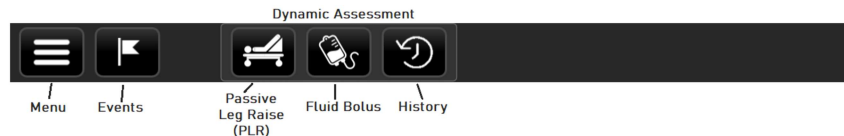

Fig. 5-14: Control bar elements

While the Argos is monitoring, the status bar displays patient information, date and time, monitor mode of operations and a battery icon showing the power state. EMR status is shown when this feature is enabled by a software license.



Fig. 5-15: Status bar elements

5.4 The Setup Screens

5.4.1 Prepare patient

Make sure the patient has been readied for monitoring.

If using a signal from a bedside patient monitor: connect it to the designated port in the patient monitor. Then, proceed to §5.5, *Initial setup – Input patient data*.

If using direct connection to a transducer cable: Utilize a BP Transducer Kit (P/N 902-649) and a Transducer Interface Cable (P/N 650-299-117) to connect directly to the Argos monitor.

To order these accessory parts, please contact Retia customer support or a Retia representative.

Use a 4-way stopcock to connect the patient to a bedside patient monitor and the Argos monitor simultaneously.

**WARNING**

When using a transducer connected directly to the Argos monitor, make sure the transducer is leveled to the phlebostatic axis.

**WARNING**

The Argos monitor must only be used with a radial or femoral arterial catheter. Do not attempt to use the device with any other type of catheter.

**WARNING**

The BP Transducer Kit (P/N 902-649) and Transducer Interface Cable (P/N 650-299-117) are indicated for use with the Argos Monitor. No other parts should be substituted for these approved accessories.

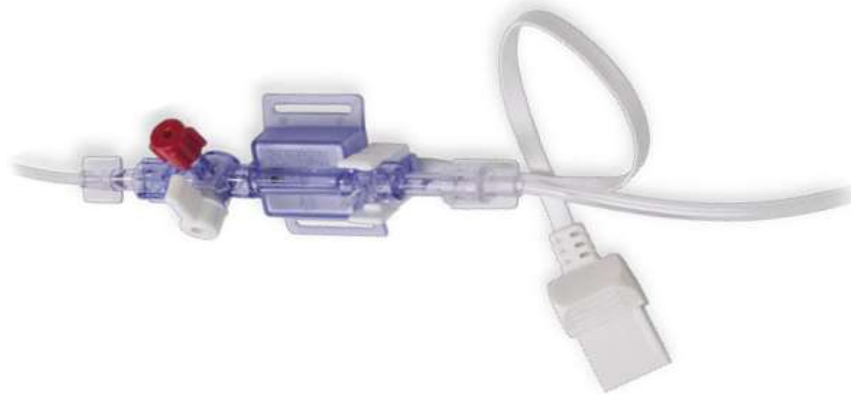

Fig. 5-16: Transducer

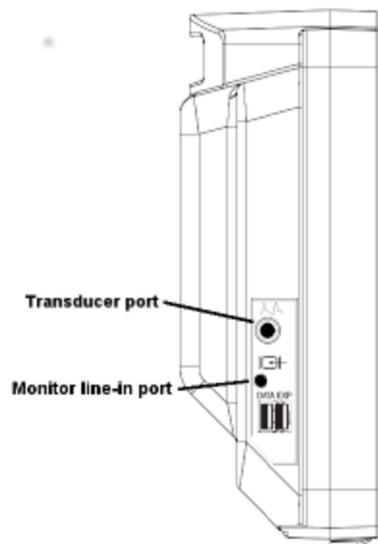

Fig. 5-17: Left side view, showing bedside patient monitor and transducer inputs

Once the patient has been fitted with a radial or femoral arterial catheter:

1. Connect the arterial catheter output line to the 4-way stopcock provided within the BP Transducer Kit (P/N 902-649).
2. Connect the transducer provided with the BP Transducer Kit (P/N 902-649) to one output from the 4-way stopcock.
3. Connect a transducer approved for use with the bedside patient monitor to another output from the 4-way stopcock.
4. Ensure that the “off” tab on the 4-way stopcock is on the 4th, unused output. An uninterrupted fluid column should exist from the arterial catheter to the BP Transducer Kit transducer and bedside patient monitor transducer simultaneously.
5. Attach the bedside patient monitor transducer to the bedside patient monitor per the manufacturer's setup instructions.
6. Attach the BP Transducer Kit (P/N 902-649) transducer to the Argos monitor via the Transducer Interface Cable (P/N 650-299-117).
7. Make sure the BP Transducer Kit transducer (P/N 902-649) is level to the phlebostatic axis.
8. Zero the BP Transducer Kit transducer (P/N 902-649) to the Argos monitor using the procedure described below in §5.7.2, page 62. Then begin monitoring the patient.

5.5 Initial setup – Input patient data

Whenever the Argos monitor is powered on, or a new monitoring session is started (after a previous patient session is ended, the Add Patient Data screen is displayed:

Mar 10, 2023
12:44:08 PM

Add Patient Data

Patient ID: Enter

Gender: Enter

Age: Enter

Weight: kg lb Enter

Height: cm ft,in Enter

Use Previous Patient Save

Fig. 5-18: Initial setup screen: Add Patient Data

Default unit system for patient demographic information is metric. To choose imperial units, use the unit toggle to adjust for lbs and ft/in before entering the patient's information.

Mar 10, 2023
12:44:20 PM

Add Patient Data

Patient ID: Enter

Gender: Enter

Age: Enter

Weight: kg lb Enter

Height: cm ft,in Enter

Use Previous Patient Save

Fig. 5-19: Metric units shown selected

- ↪ Note that active or selected values in the Argos display as bold white text against a black background. Deselected values show as light gray text against a darker gray.



WARNING

All fields must be completed accurately in order to ensure calculations of monitored values and indices are correct.



WARNING

Each patient must be given a unique ID. Patient IDs may be up to nine alphanumeric characters in length. Consult facility policy for distributing and tracking Patient IDs for instrument use.

When continuing to monitor the same patient as before:



WARNING

Never start monitoring from “Use previous patient” unless the user has verified the patient is the same patient as monitored immediately beforehand. Always carefully check that each value of the patient's demographic information is correct before proceeding with monitoring. If monitoring a new patient, use the menu to *End Session*.

The Add Patient Data screen permits quick entry of the previous patient's demographic information. To restart monitoring of the patient, tap Use Previous Patient:

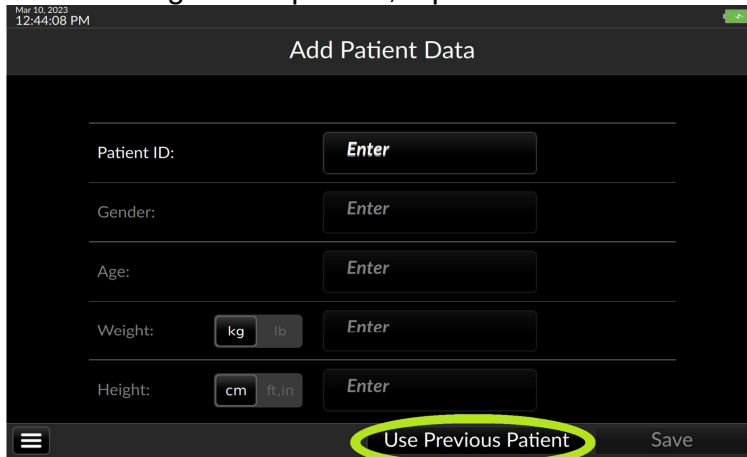

Fig. 5-20: Touch Use Previous Patient

The previous patient's demographic information appears, along with a user prompt.

- Trends less than one day old will display when Use Previous Patient is selected. Otherwise, trend data is archived and is only available via export (see §5.11.4).
- The Argos monitor has a data capacity of 1200 hours.

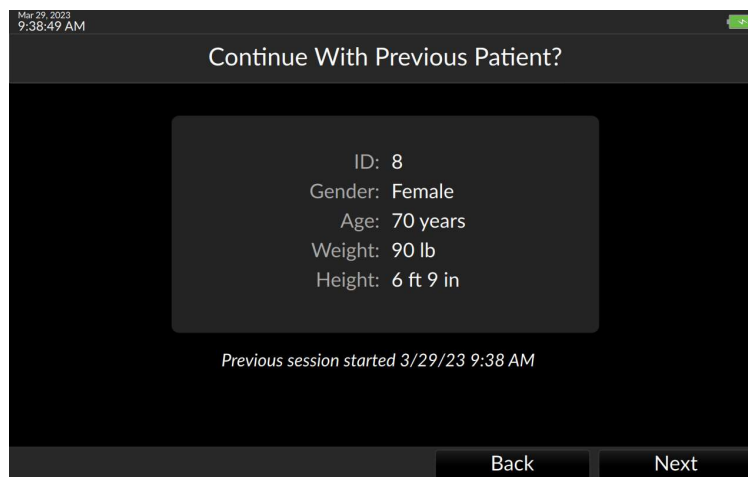

Fig. 5-21: Verify previous patient information is correct

Confirm demographic information is correct before proceeding.

**WARNING**

If the patient's demographic information as entered needs to be changed, it is necessary to start a new patient session.

Be sure the patient and demographic information match exactly before pressing *Next* to proceed with monitoring. Should any of the information fail to match, press *Back* to return to the Add Patient Data screen and enter the patient's demographic data.

When monitoring a new patient:**WARNING**

Once a user ends a monitoring session for a patient and another patient has been monitored, data for the first patient's session can only be exported via data export port, and can no longer be viewed on the Argos monitor.

**WARNING**

Start a New Patient Session whenever a new patient is connected to the Argos monitor. Failure to do so may result in previous patient data in the historical displays.

To fill in a value, press the box marked *Enter*. A popup keyboard appears.

- *It is necessary to enter a Patient ID number for each patient before monitoring. The Patient ID number can be from 1-9 alphanumeric characters in length.*
- *The Patient ID's sole purpose is to tag and identify the patient internally in the Argos monitor's database.*

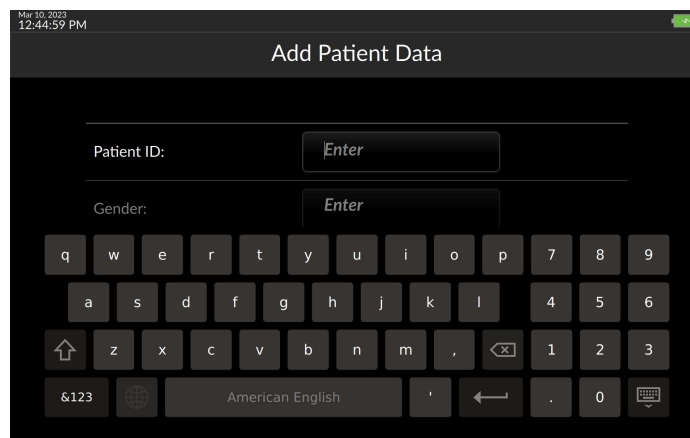



Fig. 5-22: Tapping Enter opens the alphanumeric keypad

Use the keyboard to enter the value for the patient ID. Touching the Enter key  dismisses the keyboard.

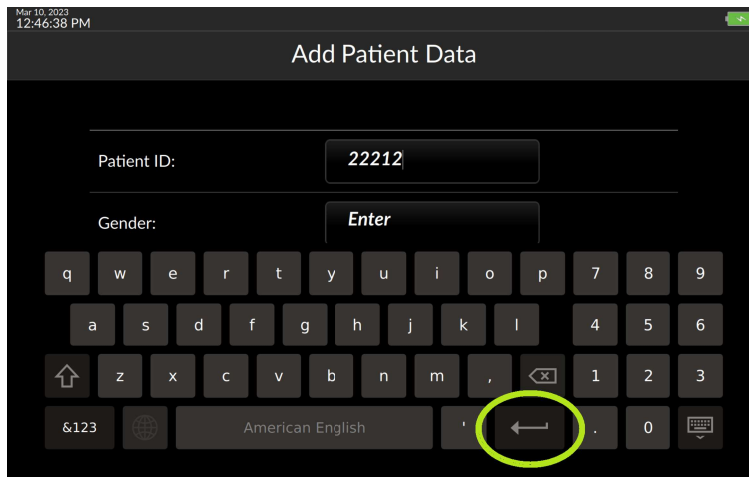

Fig. 5-23: Press OK to save and continue entering data

Touching the Gender entry field brings up a selection drop down.

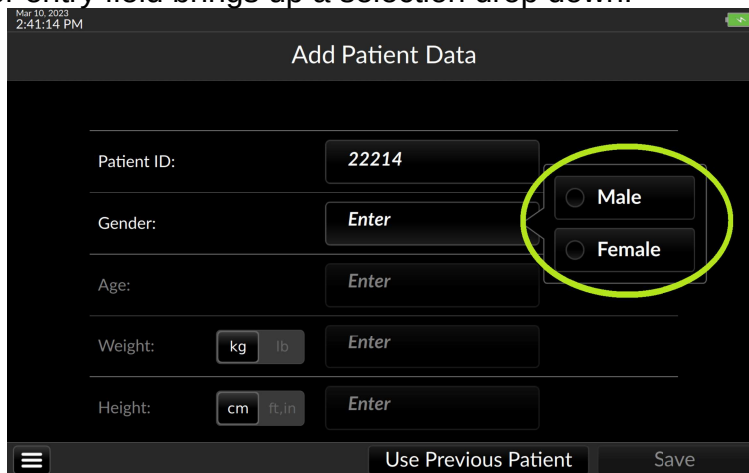

Fig. 5-24: Select from the Gender drop down

Pressing any of the remaining demographic entry fields summons a virtual numeric keypad.

Mar 10, 2023
12:48:01 PM

Add Patient Data

Patient ID: 22212

Gender: Female

Age: 63 years

Weight: kg lb 167 lb

Height: cm ft,in 164 cm

1 2 3
4 5 6
7 8 9
C 0 ~~x~~
OK

Use Previous Patient Save

Fig. 5-25: Use the virtual keypad to enter numeric values

Complete patient age, weight, and height, then touch Save at the bottom right of the screen to save and proceed.

Mar 10, 2023
12:48:20 PM

Add Patient Data

Patient ID: 22212

Gender: Female

Age: 63 years

Weight: kg lb 167 lb

Height: cm ft,in 164 cm

Use Previous Patient Save

Fig. 5-26: Save entered data and proceed

Once patient demographic information has been saved, it cannot be changed. To change patient demographic information, the user must return to the Start New Patient screen (see §Error: Reference source not found,).

5.6 Search Patient Record Database

Licensed devices configured to connect to a network patient record database (see §7.4.1.1) provide a Patient Record search function:

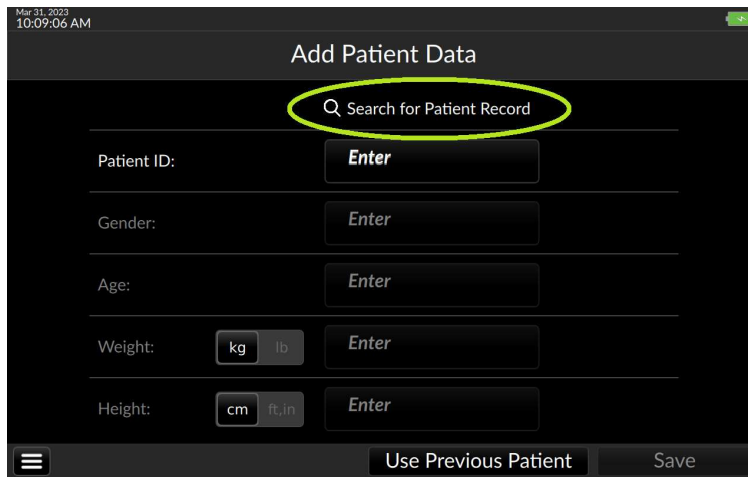

Fig. 5-27: Search for Patient Record (Corepoint)

Touch the magnifying glass icon to bring up a search box:

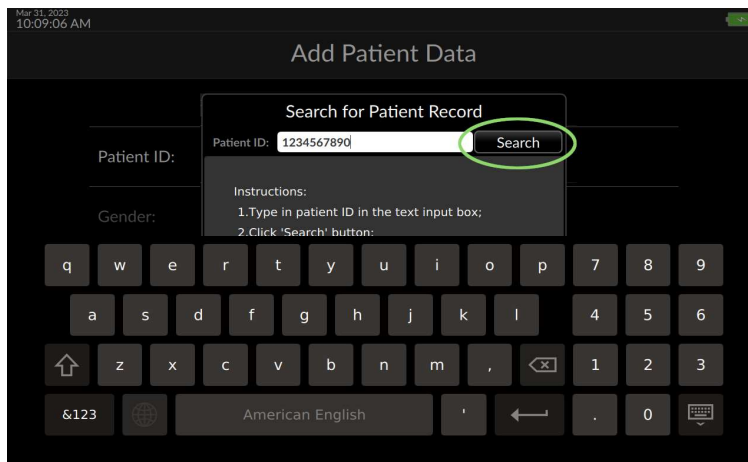

Fig. 5-28: Search for patient record continued

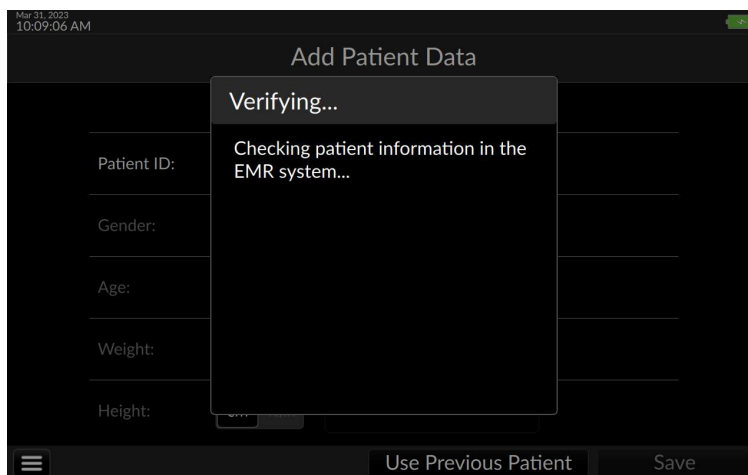

Fig. 5-29: Verifying patient record

More information can be found in §6.1.1, p. 119, **EMR Integration**.

5.7 Steps before monitoring

Once patient information has been entered, the Argos monitor is ready for use in conjunction with a bedside patient monitor; or if connected to a transducer, for zeroing the transducer prior to monitoring.

When the user has completed and saved patient demographic data entry, or have confirmed the previous patient information is correct, the Select Blood Pressure Signal Source screen appears.



WARNING

The Argos monitor presents visual alerts when parameter limits are exceeded, but does NOT provide audible alarms. Audible alarms are the function of the bedside patient monitor.

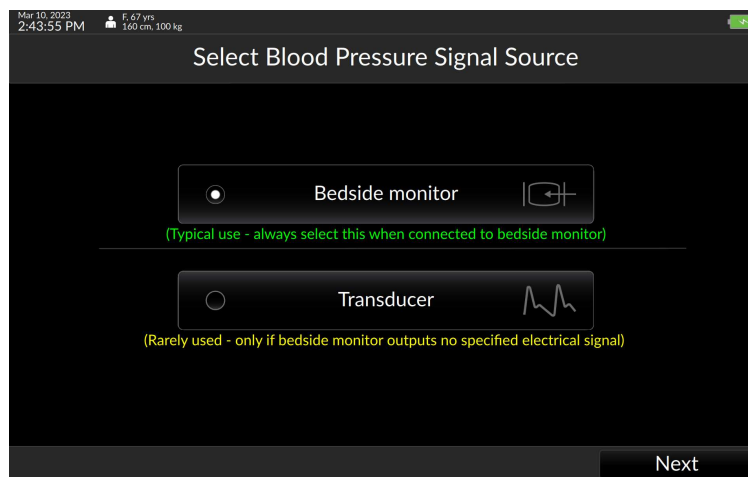

Fig. 5-30: Select BP Signal Source

Monitoring commences immediately and the Trend screen appears.

5.7.1 Connected to a bedside patient monitor:

If the Argos monitor is connected directly to the bedside patient monitor, ensure *Bedside Monitor* is selected, then press *Next*

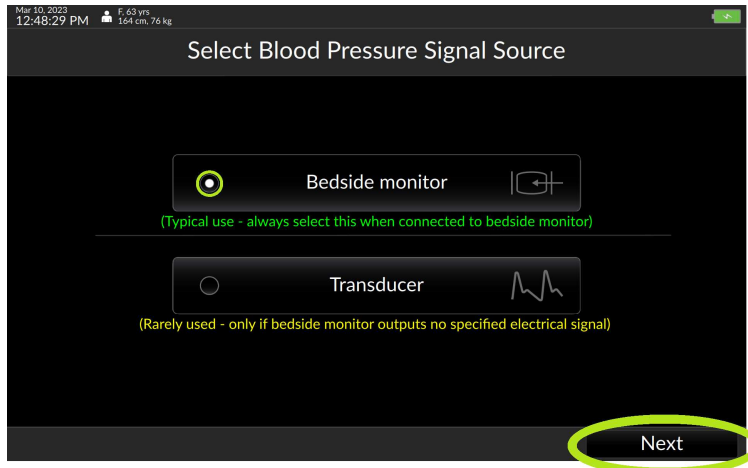

Fig. 5-31: "Bedside Monitor" selected; press Next

5.7.2 Connected directly to a radial or femoral artery transducer:

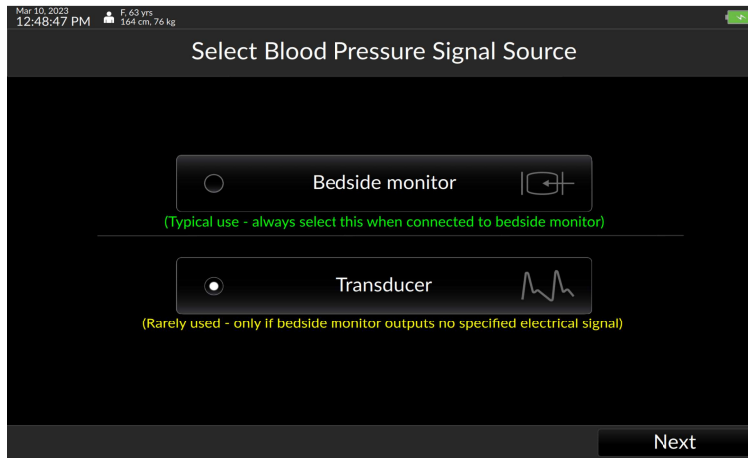





Fig. 5-32: Select Transducer and then press Next

	WARNING Failing to zero the transducer correctly may lead to incorrect monitoring results.
	WARNING The Argos monitor is intended only to supplement patient assessment, and must <i>only</i> be used in conjunction with a bedside patient monitor.
	WARNING If the Argos monitor is connected directly to a transducer, the transducer must also be connected simultaneously to a bedside patient monitor.

If the Argos is connected directly to the patient arterial line, it is necessary to zero the transducer immediately prior to monitoring. If *Transducer* has been selected as a BP

source, pressing *Next* at the bottom of the screen initiates the Zero Transducer procedure.

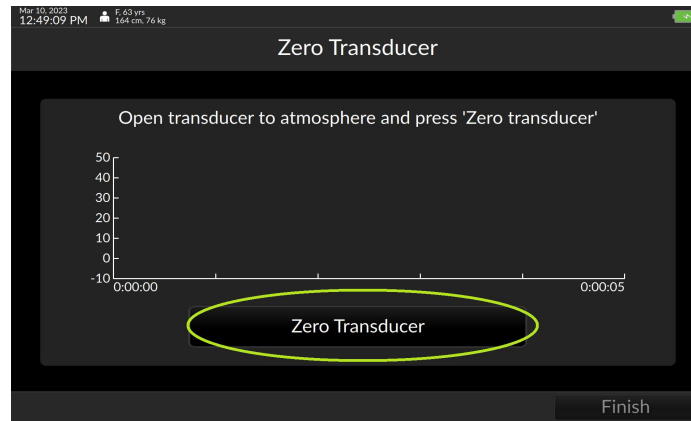

Fig. 5-33: The Zero transducer screen

Open the stopcock on the transducer line to the atmosphere. Then, press *Zero transducer*.

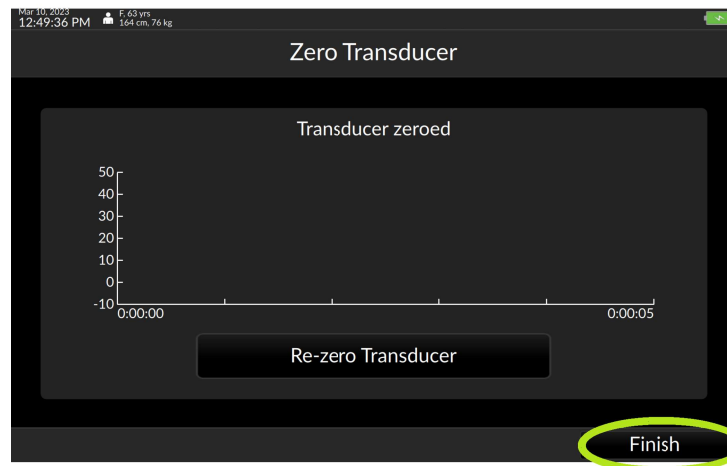

Fig. 5-34: Press finish to begin patient monitoring

Once the user has verified the pressure curve is flat, press *Finish*. The Argos begins monitoring.

Please verify the alert functionality whenever the device is turned on, immediately after beginning a new monitoring session. This procedure is described in Appendix 8.12, p. 153.

5.8 The Trend Screen

At startup, the Argos monitor displays the previous session's selected parameters.

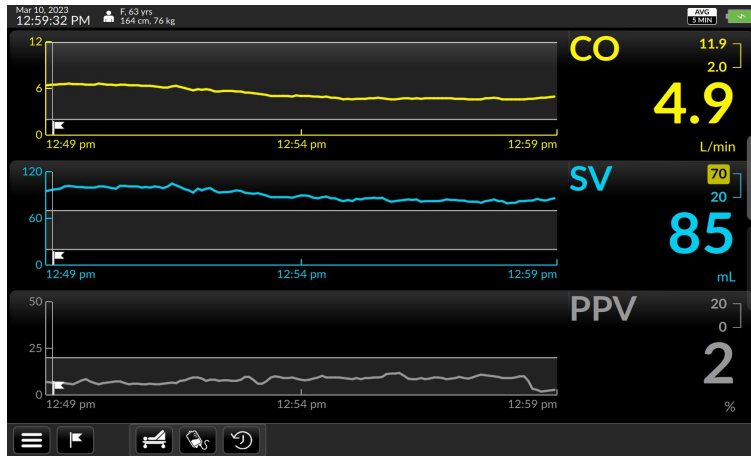

Fig. 5-35: The Trend screen

The Argos can display these parameters:

- Cardiac output (CO)
- Cardiac index (CI)
- Mean Arterial Pressure (MAP)
- Heart Rate (HR)
- Pulse pressure variation (PPV)
- Stroke volume (SV)
- Stroke volume index (SVI)
- Systemic vascular resistance (SVR)
- Systemic vascular resistance index (SVRI)
- Heart rate (HR)
- Blood pressure (BP)

5.8.1 The Parameter Settings Screen

To change displayed parameters, access the Parameter settings screen by pressing the parameter label. The Parameter settings overlay/tab allows the user to easily select a different parameter, change colors, adjust visual alert limits, and display additional information in the parameter label.

To select a different parameter:

Touch inside the label the user wishes to change to access the Parameter settings tab, then select the desired parameter from the dropdown.

If the user wants to change the CO trend to MAP (Mean Arterial Pressure): start by pressing the CO parameter label:

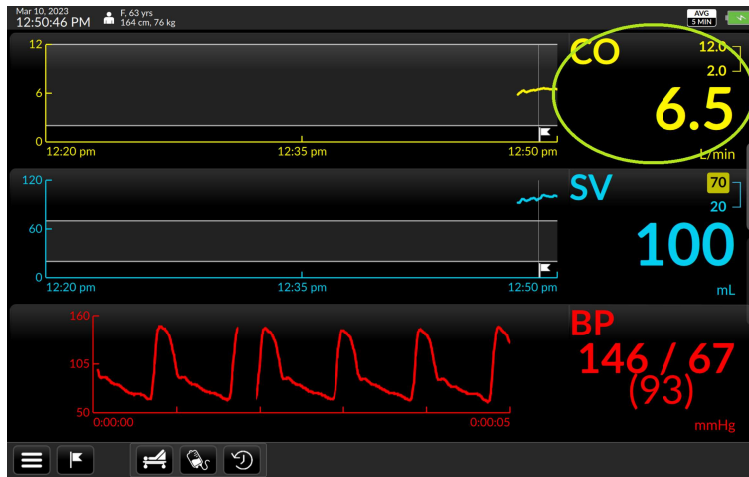

Fig. 5-36: Press any parameter label to change the displayed trend

The Parameter settings tab opens, with the currently-displayed parameter's initialism shown inside a selection box with a downward-facing triangle. Press it.

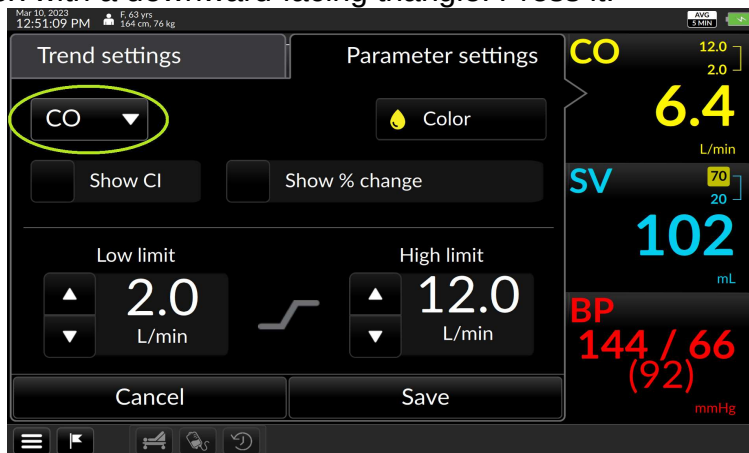

Fig. 5-37: Tap the current trend name inside the box to change it

A drop down list appears.

Scroll up or down to view the complete list.

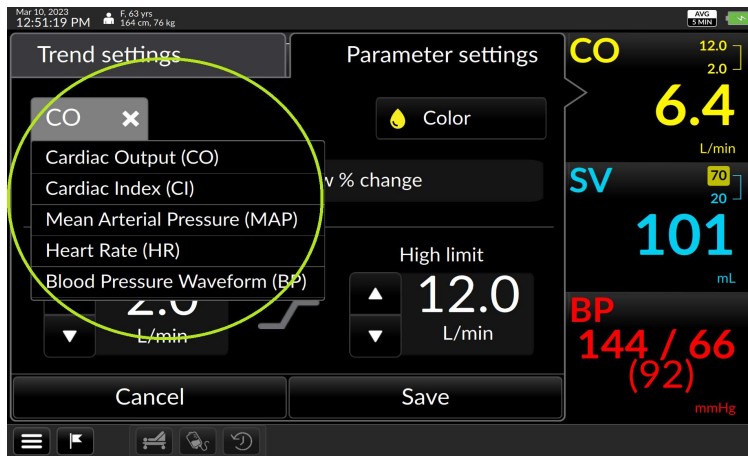

Fig. 5-38: The drop down list of trends

Tap on the name of a trend to select it. The selection box closes.

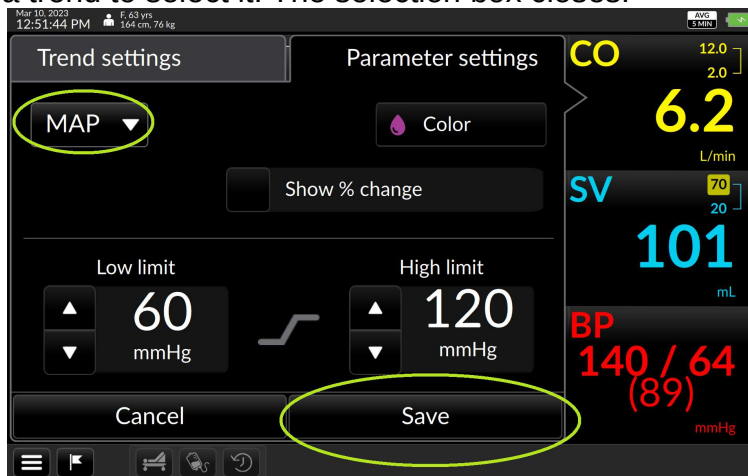

Fig. 5-39: MAP selected. Press Save to continue

Press the Save to save the selection and return to the main Trend screen. The selected parameter is now displayed.

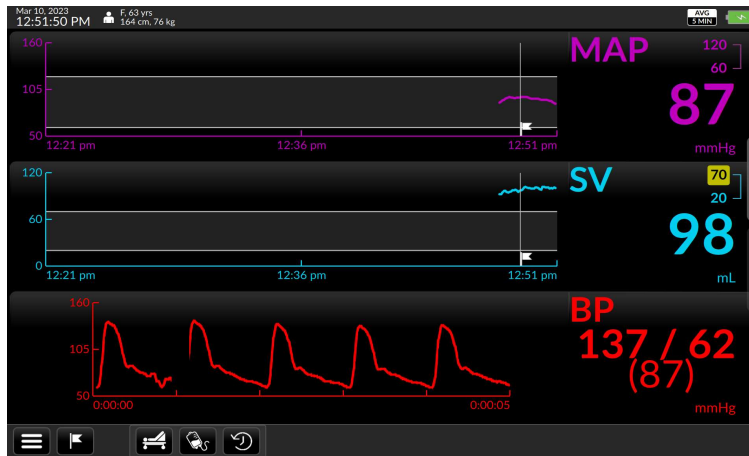

Fig. 5-40: MAP displayed

- The Argos retains the selection of parameters between sessions. If the user desires to return to the default selection of monitored parameters, navigate to User Menu/Device Settings, then tap the box labeled Reset to default configuration. Factory default settings will be reloaded.
- Should the user select a parameter that is already being displayed in a different trend window, the currently-selected parameter will display the one the user selected, but the previous parameter will display in the other trend window.
- The Parameter Settings page may also be used to show additional monitoring information in the label.

5.8.2 Display change since event

The User can show the net change in any parameter since an event – including monitoring initialization, or from an event that has been marked. For example, while monitoring a patient's cardiac output (CO) if the user wishes to track the net change in CO over a period of time then call up the Parameter Settings window by tapping the Parameter Label:

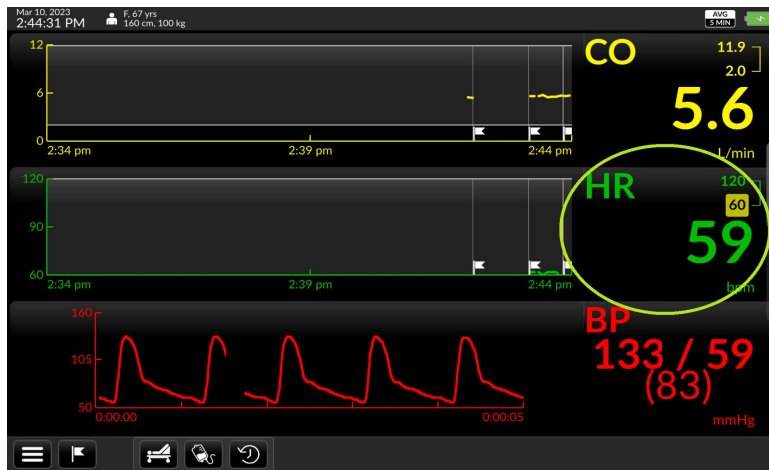

Fig. 5-41: Touch the label to access Parameter settings

The Parameter Settings page opens. Show % change is located near the center of the screen.

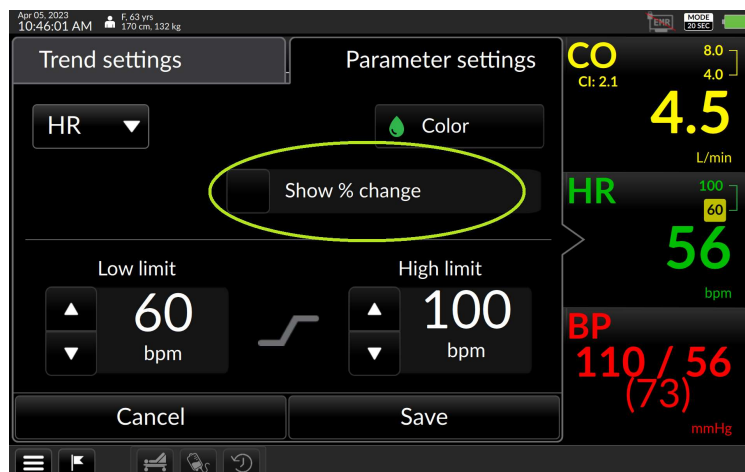

Fig. 5-42: "Show % change" shown highlighted

Tap the checkbox.

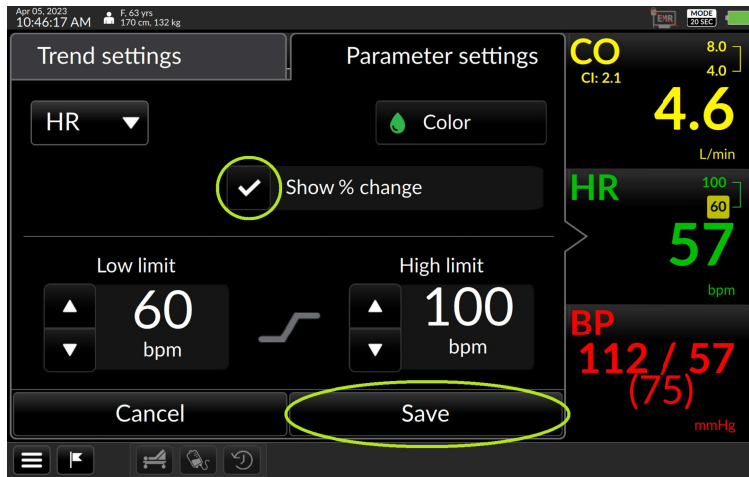

Fig. 5-43: "Show % change" box checked

Press Save to save and return to the monitoring screen. The percentage value of the change since the previous event flag is now displayed.

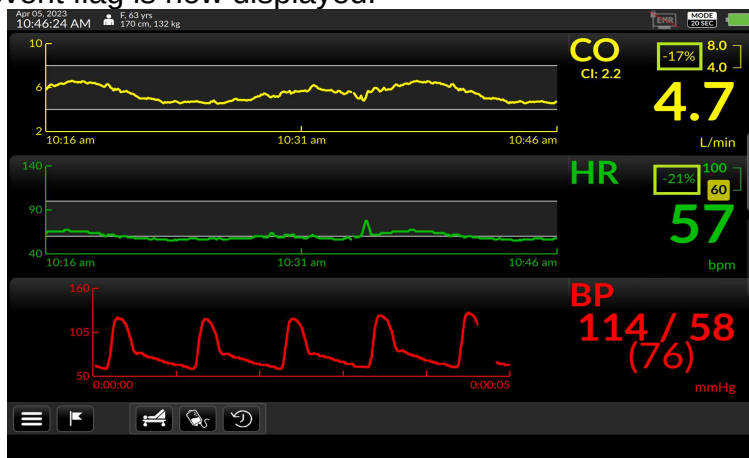

Fig. 5-44: Percentage change is measured from the flagged event

- When monitoring the response of the patient to an intervention, the user should take note of the selected monitor mode of operations, displayed in the Status Bar at the top right-hand portion of the screen. In the case of the 20 second mode option, rapid changes in the patient's hemodynamics will be reflected more rapidly in the updated parameter display, whereas with the 5-minute monitoring mode, hemodynamic changes will be reflected over a longer period of time. To change the monitoring mode, select the Device Settings option from the User Menu. Refer to §5.11.6.4, p. 98 for more information.
- Performing a Dynamic Assessment will replace the percent change figure to reflect the change from baseline of the Dynamic Assessment. A new flag representing this time point of the end of the baseline will be automatically inserted and the percent change will reflect the change from this time.

- At the end of the Dynamic Assessment procedure when the result is calculated, a new flag is inserted automatically indicating the end of the assessment. Any percent changes visible after the end of the Dynamic Assessment are calculated with respect to the time point indicated by the result flag.

5.8.3 Display an associated index or value

Certain parameters can be displayed with an associated indexed value that is normalized to the patient's body surface area

Trend displayed	Optional numerical trend value to show
Cardiac Output (CO)	Cardiac Index (CI)
Stroke Volume (SV)	Stroke Volume Index (SVI)

Suppose the user is monitoring Cardiac Output and wish to display the patient's Cardiac Index. Access the Parameter Settings page by touching the parameter label on the main screen. The *Show CI* selector is found on the left-hand side of the screen.

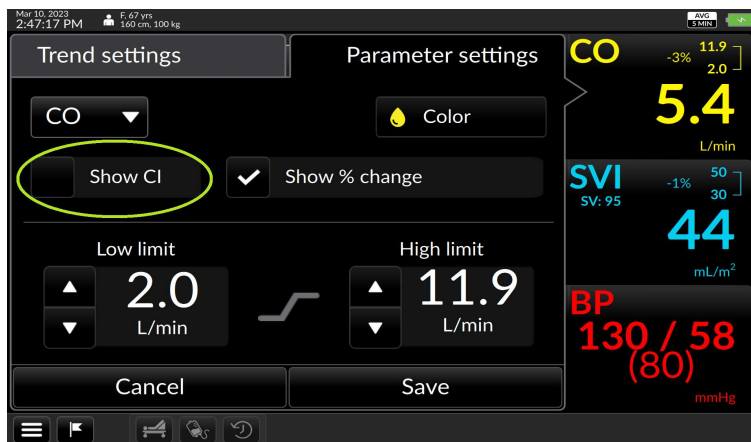

Fig. 5-45: "Show CI" selection box highlighted

Tick the box to display CI. Press Save.

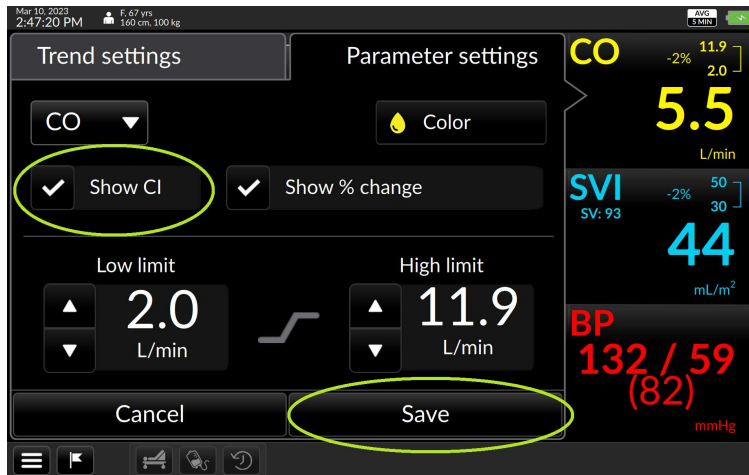

Fig. 5-46: Tick the box, then tick Save

to return to the Trends screen, showing the CI value in the label.

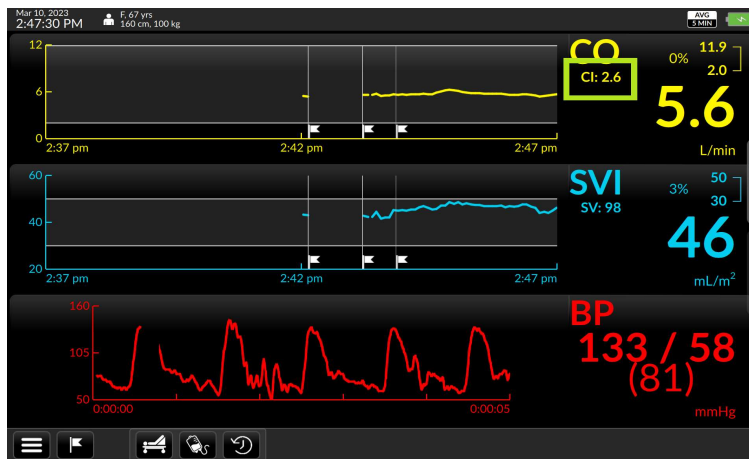

Fig. 5-47: CI now displayed in Parameter label

5.8.4 Changing colors and graph limits

From the Parameter Settings page, the user can also

- change the color of a trend and text
- change maximum and minimum limits of the parameter graph value (Y-axis)

To change trend display color:

Touch inside the parameter label field to call up the Parameter Settings overlay. The color selector is marked by a droplet icon bearing the currently-displayed color:

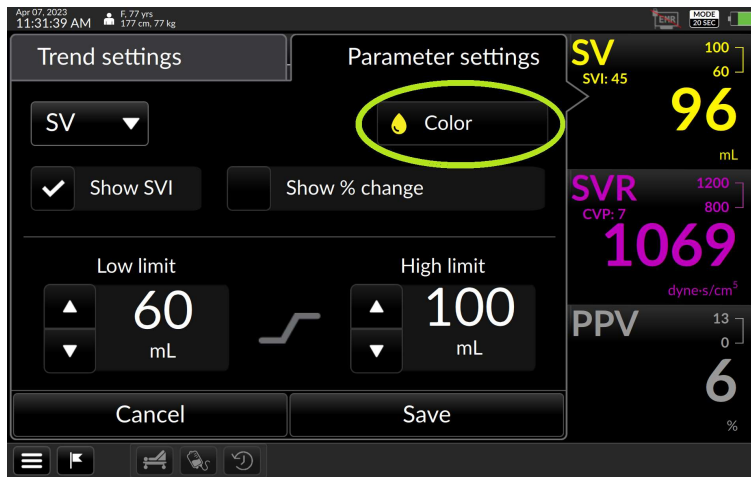

Fig. 5-48: The Color selector

Touching the color selector brings up a palette of colors:

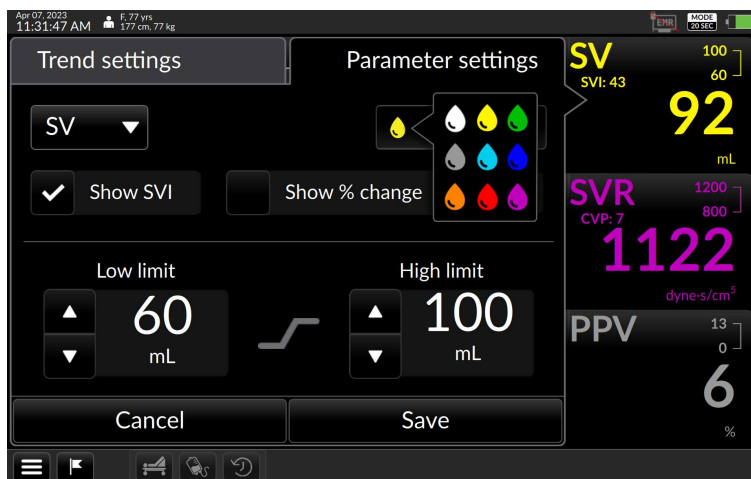

Fig. 5-49: Color selection

Choose a preferred color.

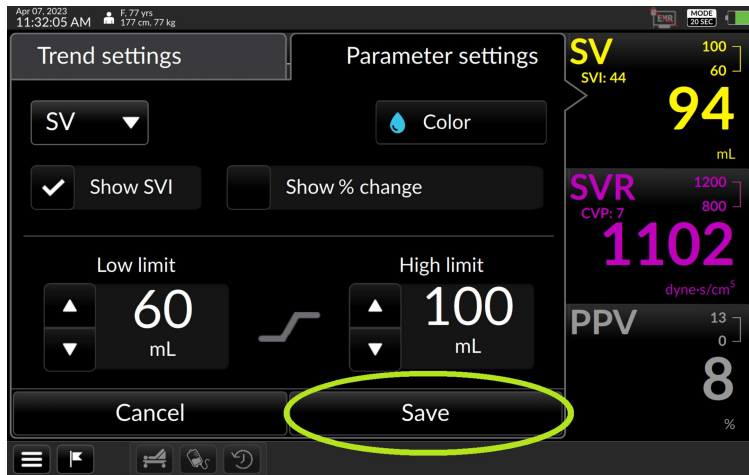

Fig. 5-50: Blue is selected

Press Save to save the value and return to the trend screen. The parameter shows in the chosen color.

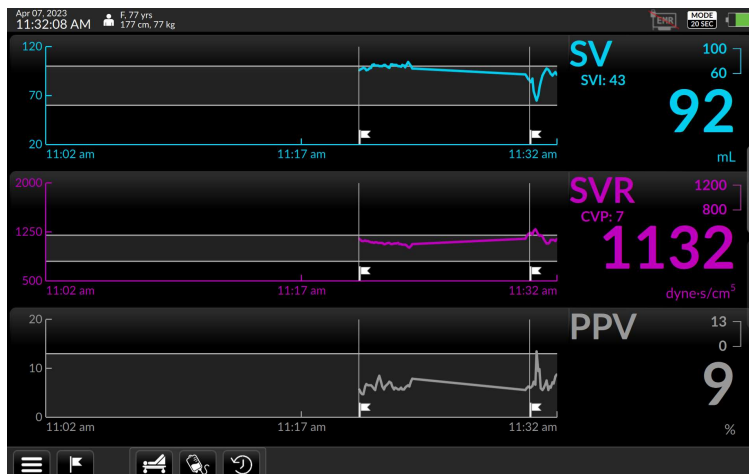

Fig. 5-51: SV trend and label displayed in blue

5.8.5 To change alert limits:

Bring up the Parameter Settings overlay by pressing the parameter label field. Both low limits and high limits are shown.

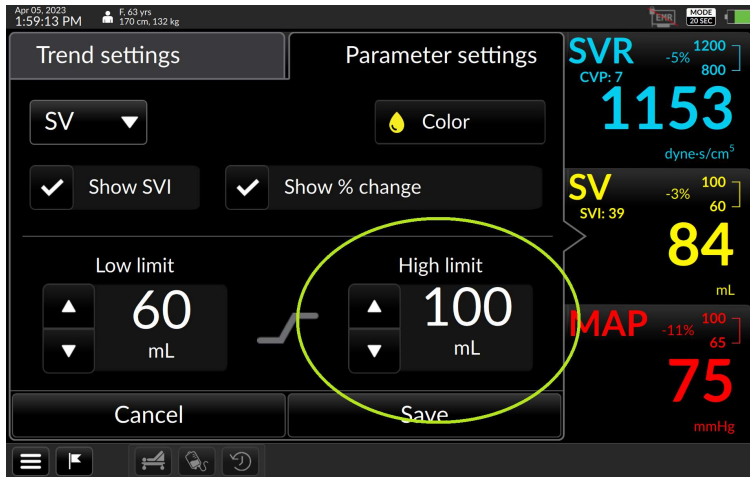

Fig. 5-52: High limit adjuster in Parameter settings

Adjust the value by tapping the up arrow or down arrow until the desired limit is reached.

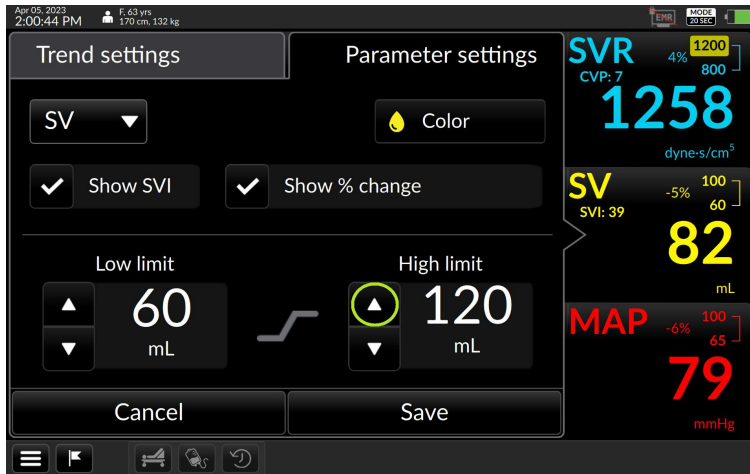

Fig. 5-53: Increase the limit with the upturned triangle

Adjust the values to the desired setting and press Save to return to the main monitoring screen

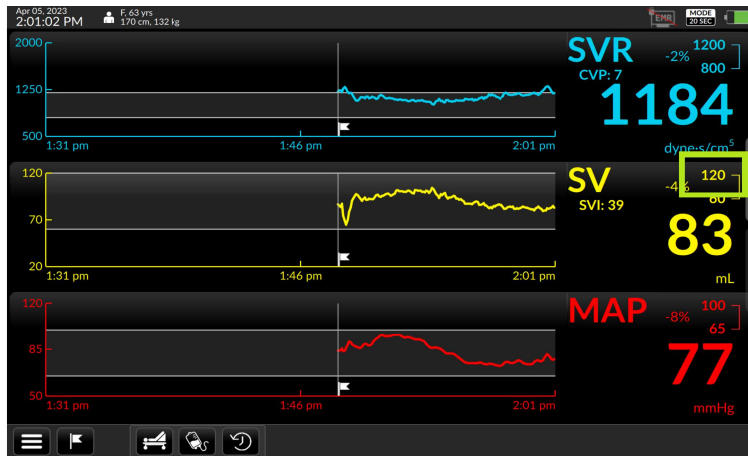

Fig. 5-54: CO upper alert limit reached

5.8.6 Moving chronologically through trends

The User can rapidly examine trend history by swiping a trend to the right (moving to an earlier timeframe) or to the left (to a later time).

Note that only the trends recorded from the last monitored patient may be reviewed on the monitor, provided they have been recorded entirely within the previous 24 hours.

- ☞ *The Argos monitor can store up to 1200 patient hours of data in its memory. To access prior patients' data, use the Data Export function with a USB drive (§5.11.4).*

Placing a fingertip on a trend brings up a light gray triangle at the left hand side:

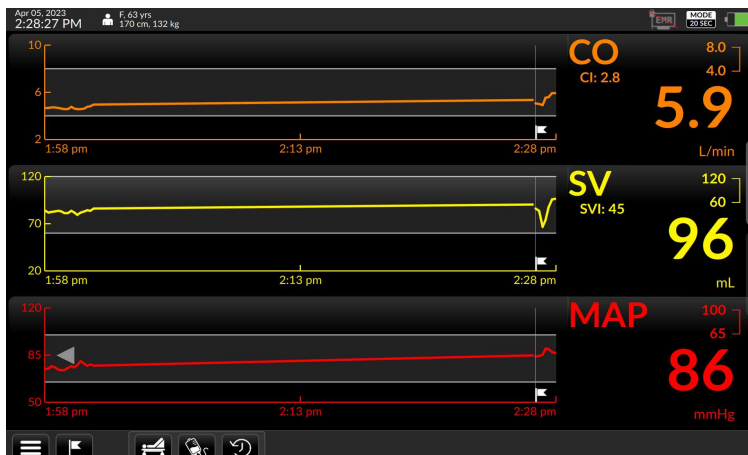

Fig. 5-55: A fingertip touching the MAP trend brings up a gray triangle

Note the gray arrow appearing on the trend coordinate line when holding and scrolling to see past trend data:

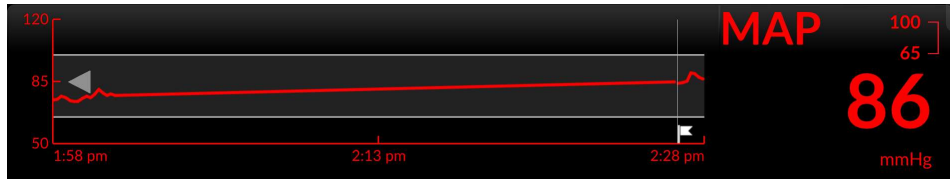

Fig. 5-56: Closer view of trend and label

When the trend has been shifted to an earlier timeframe, another gray arrow appears on the right side while the timeframe is being moved.

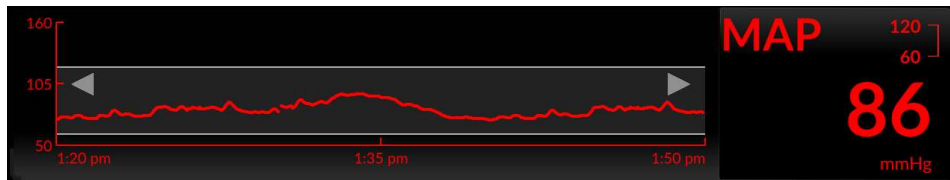

Fig. 5-57: Arrows at both ends of the trend indicate an earlier view

To return to real-time, swipe left as far as the trend will go.

5.9 Trend Settings

5.9.1 Scaling trends

The size of the time period shown – the scale of the X-axis – can be adjusted to any value between 10 minutes and 12 hours; by default the time scale is 10 minutes.

Fingertip control allows rapid rescaling. To compress the trends – to show a *larger* time interval – place the tips of a thumb and forefinger, or two fingers, horizontally on a trend, and draw them together in a pinching motion.

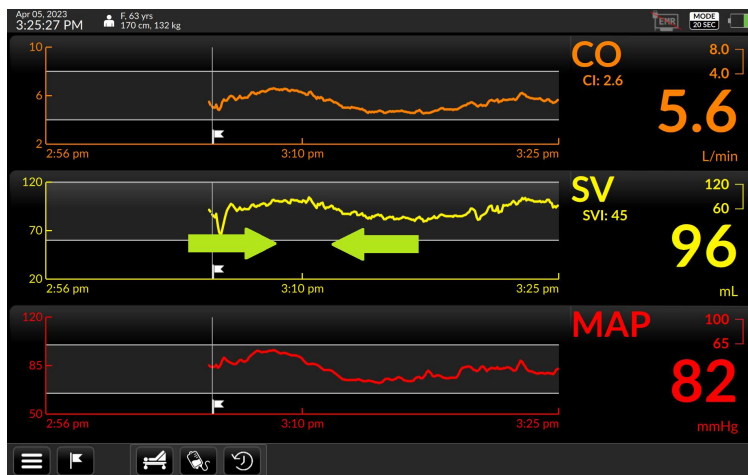

Fig. 5-58: Draw two fingertips together to compress the time scale

The trend's time axis will take in a greater duration.

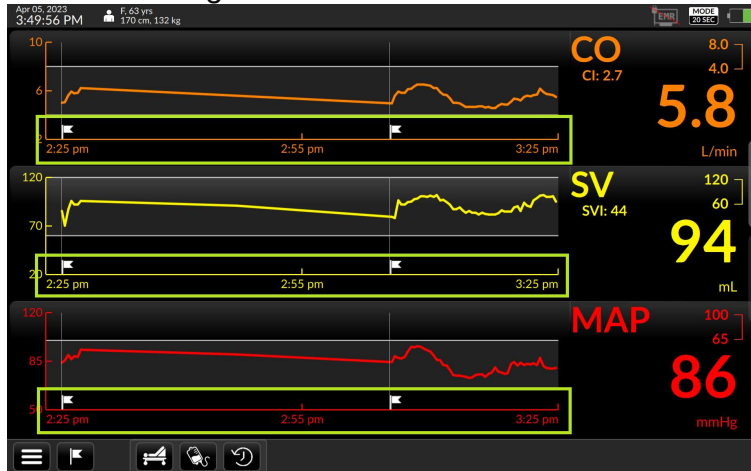

Fig. 5-59: All three trends are lengthened to approximately one hour

To expand the time scale – to show a *smaller* interval in the trend windows – spread two fingertips apart

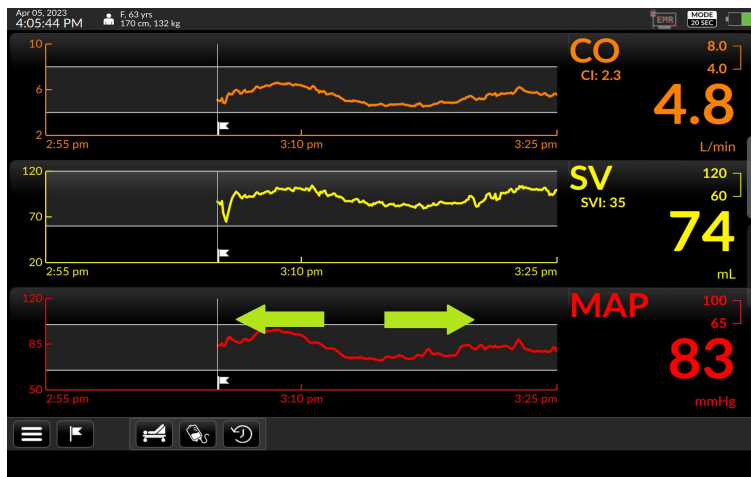

Fig. 5-60: Time scale is 30 minutes before manual adjustment

The time scale has now gotten smaller, in this case to ten minutes, the smallest available viewable time scale.



Fig. 5-61: The time scale is approximately 10 minutes

5.9.2 Trend settings: Scaling trends

The User may change the time scale from the default 10 minutes to a preset numeric unit of time from the Trend settings page as well. By default, trends display over 10 minute intervals.

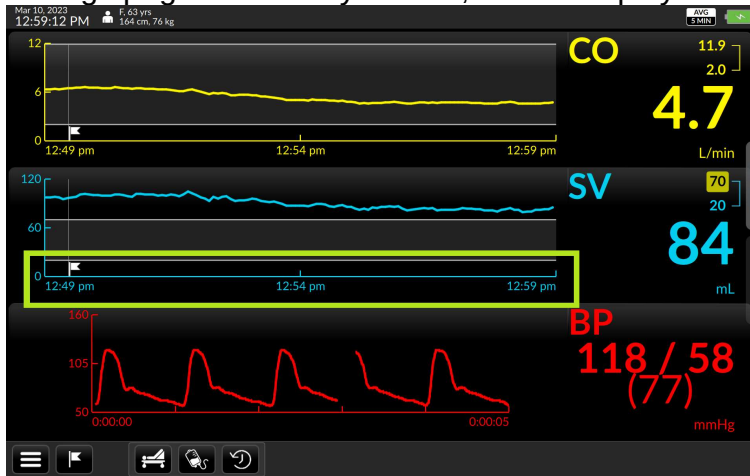

Fig. 5-62: Default trend time scale is 10 minutes

Tap a trend with a fingertip.

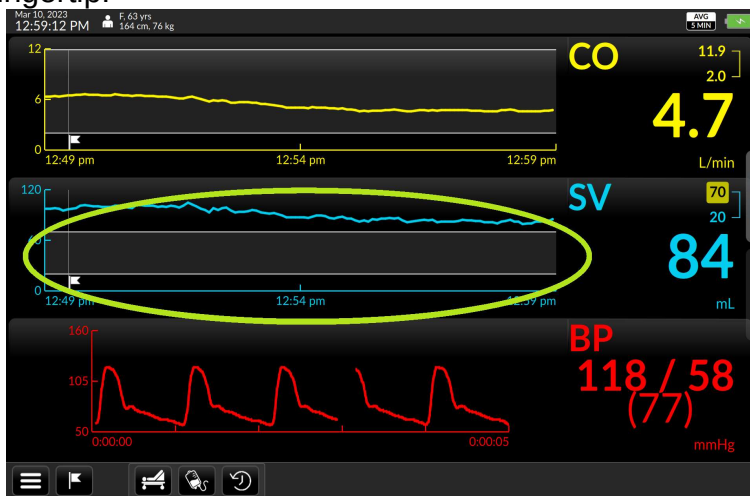

Fig. 5-63: Access Trend settings by pressing a trend

The Trend settings page opens. Current Time Scale interval is displayed in a selector box.

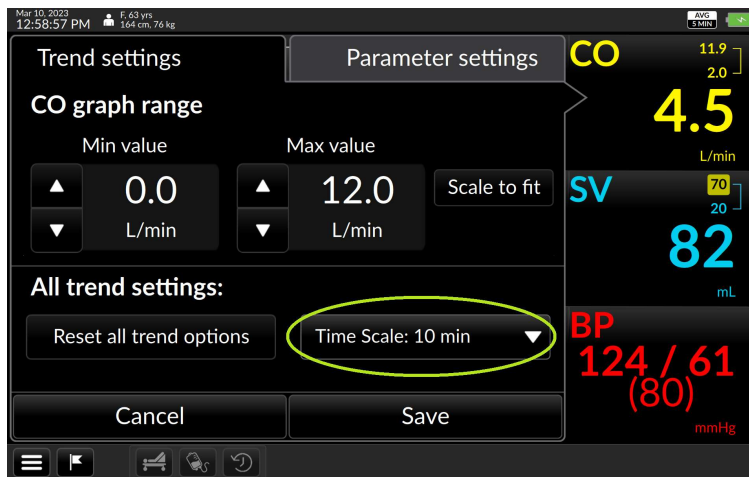

Fig. 5-64: Time scale is shown on Trend settings

Tap the box. A drop down menu lists a choice of possible intervals:

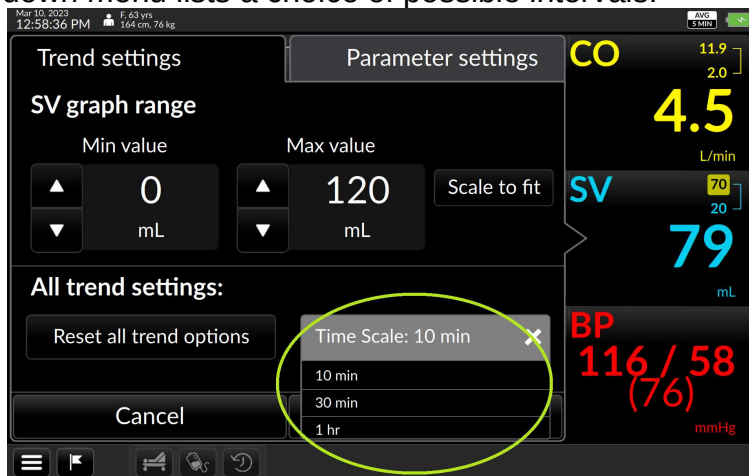

Fig. 5-65: Time scale intervals range from 10 minutes to 12 hours

The Time Scale selection box is set to 10 minutes by default. Touch it to adjust it. Possible values are 10 minutes, 30 minutes, 1 hour, 2 hours, 3 hours, 6 hours, and 12 hours. Select the interval the user prefers, then press Save.

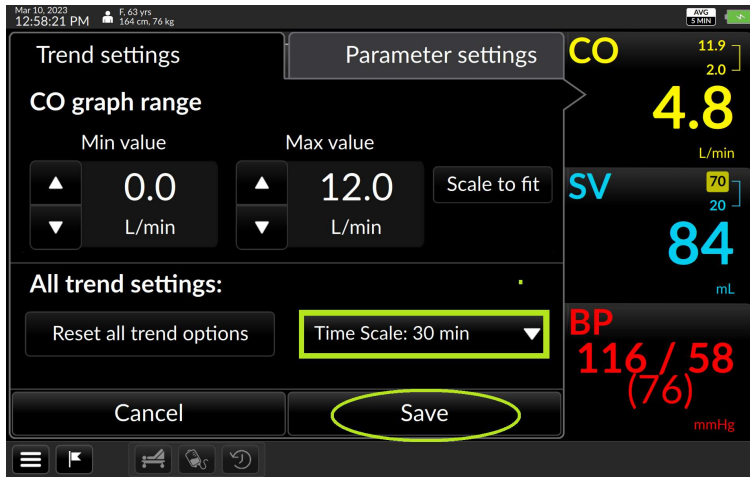



Fig. 5-66: 30 minute interval selected, press Save  Save to continue

The Trend screen returns with the selected scale.

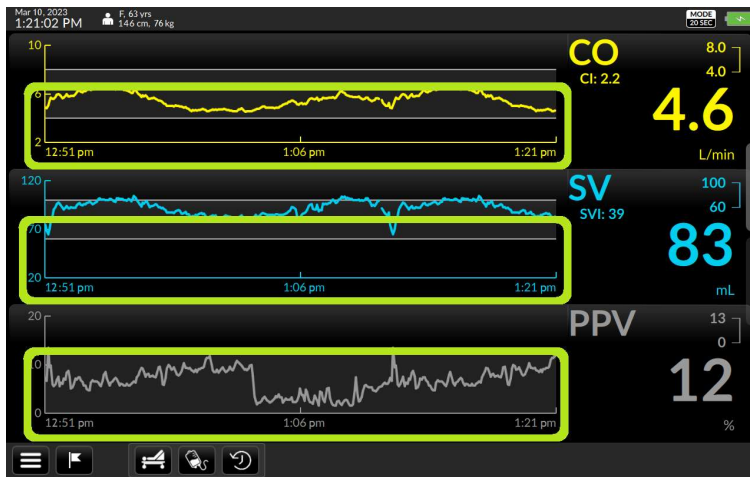

Fig. 5-67: All trends are scaled at 30 minute intervals

5.9.3 Changing the graph range (y-axis)

Maximum and minimum values of the coordinates for each trend parameter may be raised or lowered from the Trend settings screen. You can also choose to allow the trend to determine the scale values.

Suppose we want to reduce the maximum range value for Mean Arterial Pressure (MAP). To adjust graph ranges, press the trend whose y-axis range the user wishes to alter on the Trend screen to bring up Trend settings.

Note the *graph range* portion of the screen, showing Min(imum) and Max(imum) values:

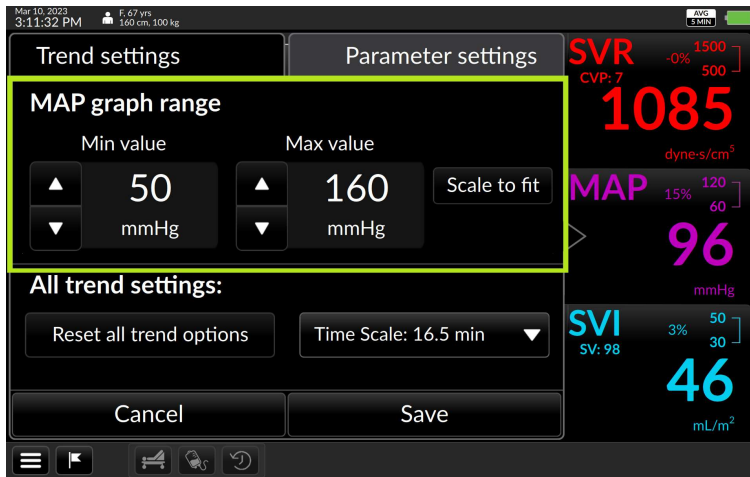

Fig. 5-68: Set MAP graph range values here

In this case, we wish to lower the maximum MAP graph value.

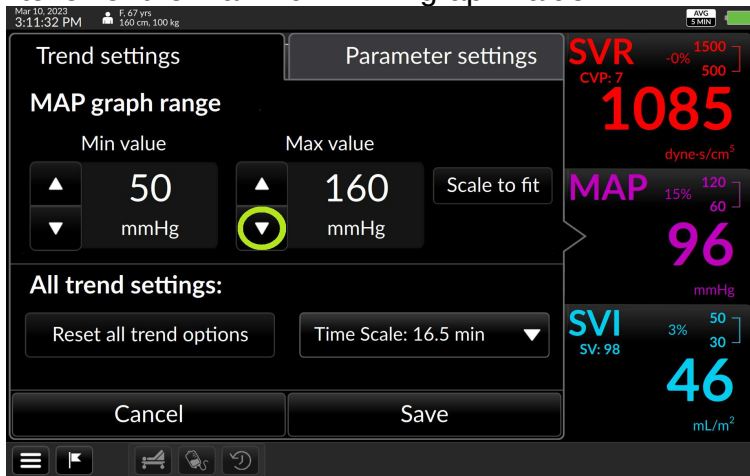

Fig. 5-69: MAP trend settings with max graph value selector highlighted

Use the triangle to incrementally decrease the numerical value.

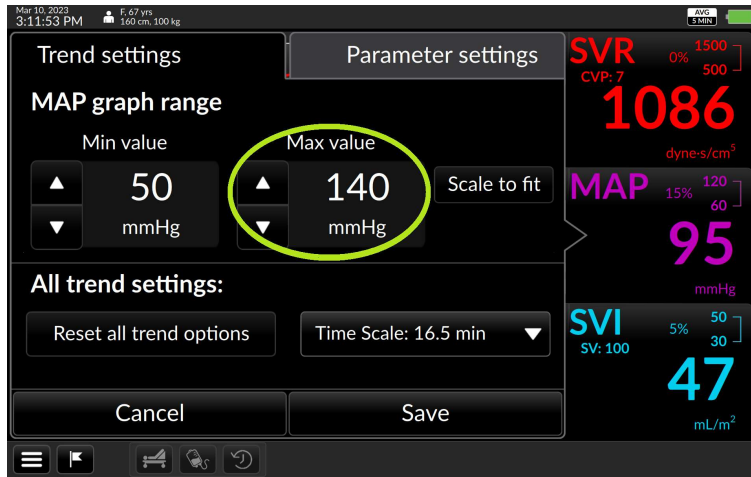

Fig. 5-70: Max graph range value is now 140 mL

Press Save to return to the Trend screen with the new value.

- *Choosing Scale to Fit allows the trend to set minimum and maximum graph coordinates.*
- *To return all Trend settings to default values for a displayed Trend, press the Reset all trend options box. Settings will revert to bootup values.*

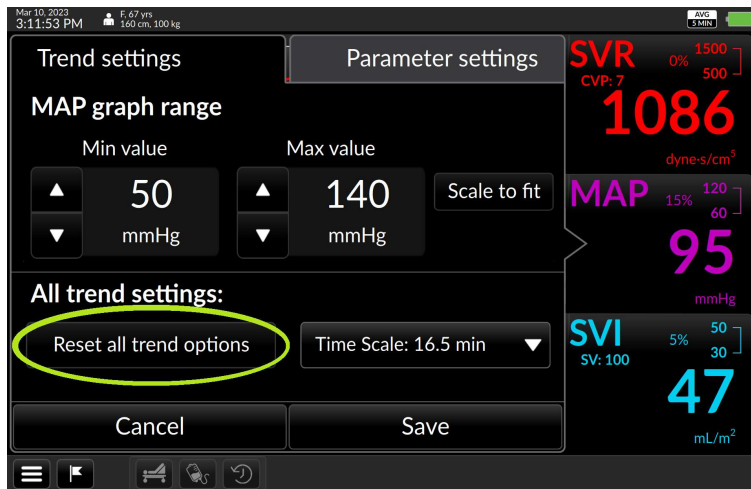

Fig. 5-71: Press Reset all trend options to return settings to defaults

5.10 The Tabular View

Tabular view presents a table of earlier discrete hemodynamic values, at a user-specified interval, during the current continuously-monitored patient session. The user may select increments of 15 minutes (the default), 30 minutes, 1 hour, or 2 hours.

Current real-time values display in green on the left side of the Tabular View screen.

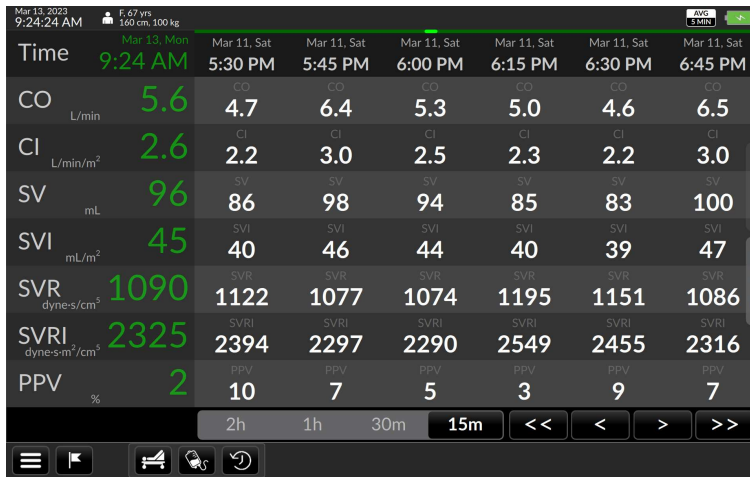

Fig. 5-72: Tabular View

The Control Bar (see §5.11, p. 86) is displayed along the bottom of the Tabular View screen and the Status Bar is displayed at the top.

5.10.1 Tabular view options

To change the time interval, tap the desired value.

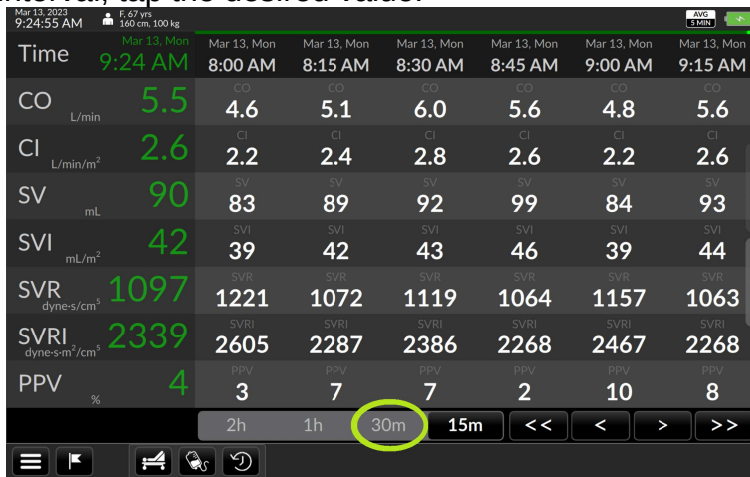

Fig. 5-73: Tap the desired interval

The increment changes to the selection.

Time	9:25 AM	6:30 AM	7:00 AM	7:30 AM	8:00 AM	8:30 AM	9:00 AM
CO L/min	5.5	6.5	4.8	6.3	4.6	6.0	4.8
CI L/min/m ²	2.6	3.1	2.3	3.0	2.2	2.8	2.2
SV mL	90	100	85	97	83	92	84
SVI mL/m ²	42	47	40	46	39	43	39
SVR dyne·s/cm ⁵	1094	1088	1139	1106	1221	1119	1157
SVRI dyne·s·m ² /cm ⁵	2333	2321	2430	2359	2605	2386	2467
PPV %	4	6	3	5	3	7	10

Fig. 5-74: Data is now shown in 30-minute intervals

Time windows can be rapidly advanced or reversed using the << or >> icons:

- << Quickly reverses Tabular View display to the start of the monitoring session
- < Reverses Tabular View display in increments of 1 hour (or selected time period)
- > Advances tabular view display to the most current values (to view past data in 1 hour increments, or selected time period)
- >> Quickly advances tabular view display to the most recently archived values

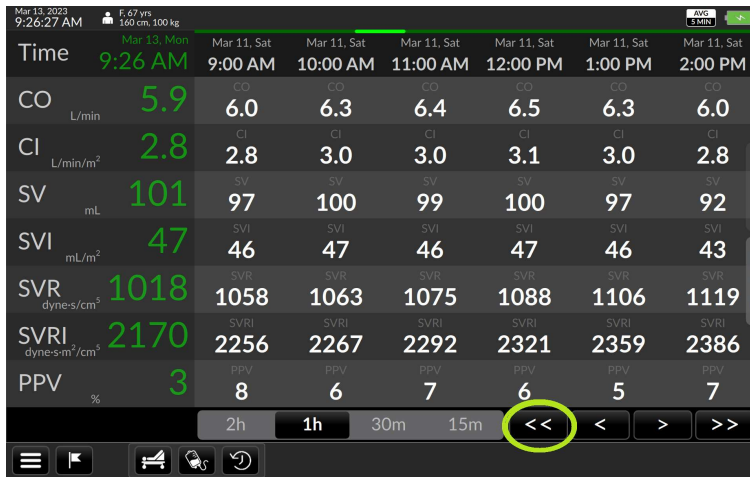

Fig. 5-75: Touch the double arrow to rewind or fast-forward data

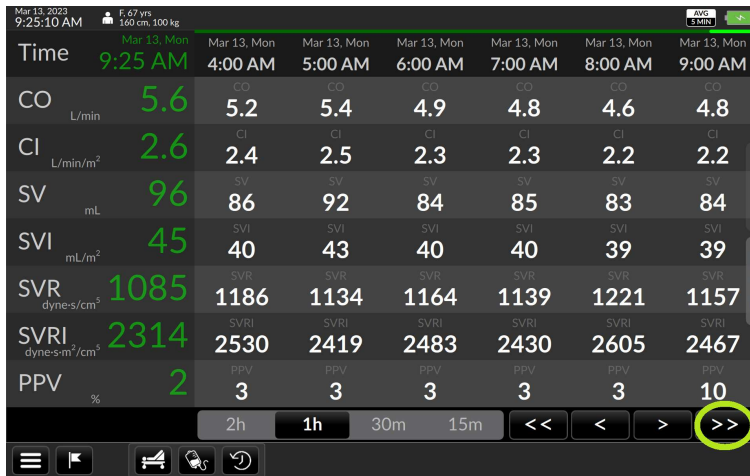

Fig. 5-76: Data rewound to start of monitoring session

5.10.2 Trend scrubbing in Tabular View

Drag a fingertip leftward on the Tabular View to scroll forward in time increments.

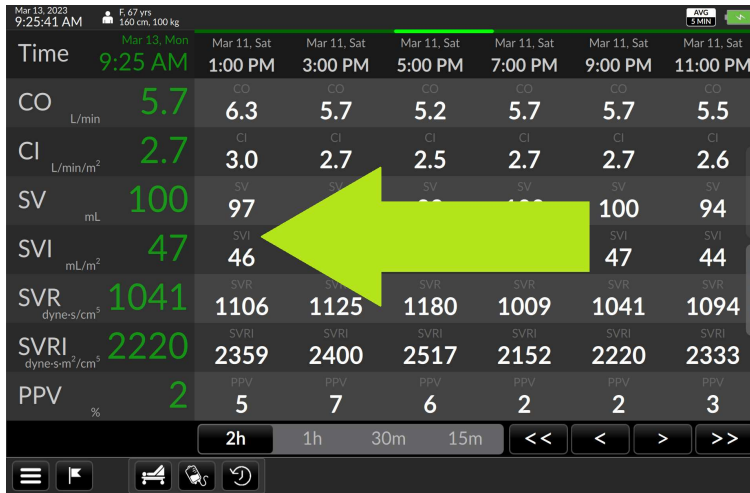

Fig. 5-77: Drag rightwards for earlier values

Drag a fingertip rightward on the Tabular View to scroll backward in time increments.

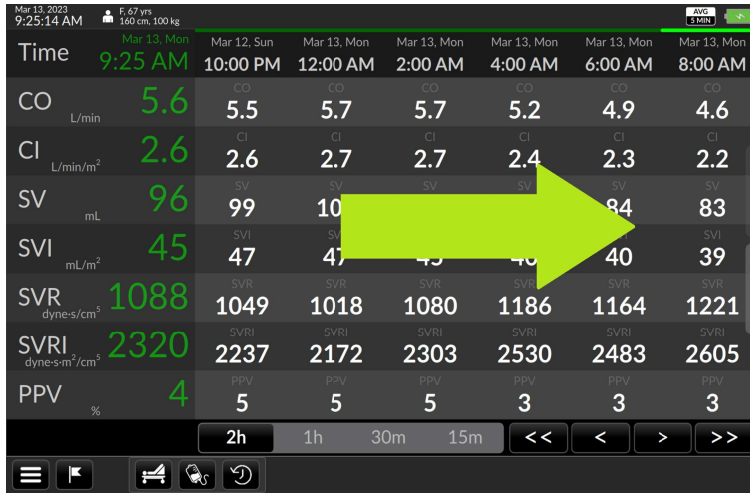

Fig. 5-78: Drag leftwards for later values

5.11 The Control Bar & Status Bar

The Control Bar at the bottom of the screen displays

- User menu access indicator
- Events access indicator
- Dynamic Assessment Functionality
 - Passive Leg Raise (PLR)
 - Fluid Bolus

- Dynamic Assessment History

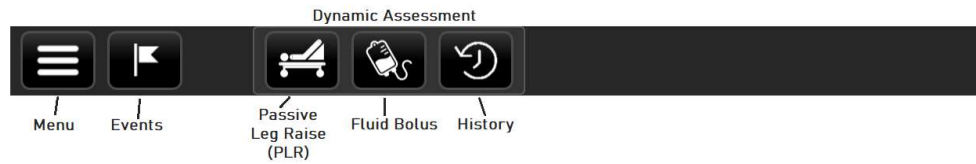

Fig. 5-79: Control Bar elements

The Status Bar at the top of the screen displays

- Patient Demographics
- Date and Time
- Power/ Battery Status
- EMR/ Network Status (if EMR enabled)
- Monitoring modes (20 seconds or 5 minutes)



Fig. 5-80: Status Bar elements

Indicators and menus provide access to critical functions, allowing the user to:

- Switch to a new patient
- Re-zero the transducer
- Access device settings
- Export monitoring logs
- Shut down
- Obtain information about the device
- Install software updates and software license
- Mark / recall events
- View system settings
- View networking and EMR status (*if EMR enabled*)
- View monitoring mode

5.11.1 Battery State Indicator

At the top far right of the Status Bar, the battery indicator displays the power level and A/C outlet connection status.



CAUTION

The Argos Cardiac Output Monitor is intended for operation while plugged into an AC wall outlet. Although it will continue to function at full capacity on battery power alone, such as when an emergency power outage occurs, it is not designed for cordless use. In case of a power outage, use of the Argos Cardiac Output Monitor should be terminated as soon as feasible.

Should the battery become disconnected from AC outlet, it will continue to supply power for approximately 30 minutes.

Table 4: Battery icons

Battery State	Icon
When the battery is properly connected to an operational external power source, the indicator icon is colored green and shows a lightning bolt	
When the battery is disconnected from external power, the icon is green, but without the lightning bolt	
As the battery loses power, the green shade lowers	
When battery power drops below 25%, the battery icon shows yellow	
Immediately prior to emergency shutdown, the battery shows a sliver of red	
If the monitor is plugged in while the battery is depleted, the bolt becomes visible as the battery charges	



WARNING

Do not unplug the device when the battery is depleted.

- ↳ The Monitor will automatically shut down if on battery power and the battery has less than 10% charge remaining.
- ↳ If the monitor abruptly shuts down immediately after booting, it is because the power supply is not attached and the battery is insufficiently charged. Plug the monitor in to continue use.

5.11.2 The User Menu

The User Menu enables the user to

- End a session and begin monitoring a new patient
- Power down
- Save patient monitoring data
- Change system settings for the Argos, including monitoring mode of operations, date and time formats, units, and language
- Export monitoring data via USB
- Restore all settings to factory default values

To access the User Menu, press the User Menu navigation icon beside the Events icon at the lower left hand side of the Control Bar:

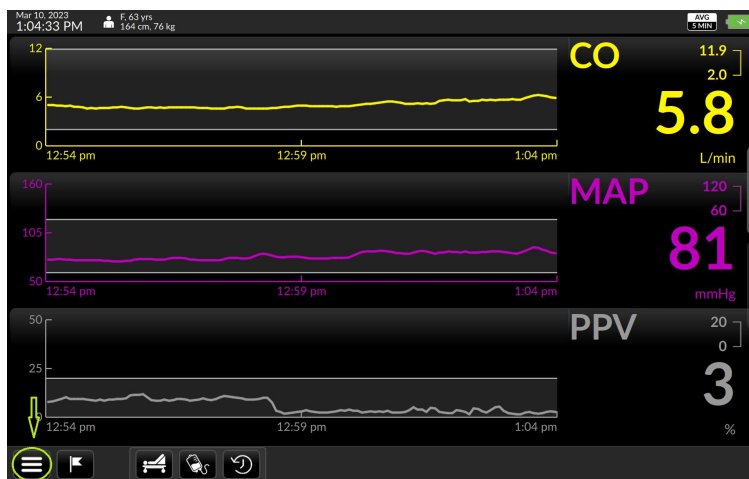

Fig. 5-81: Touch the three-lined User Menu navigation icon to access it

The User Menu appears in the bottom left-hand corner.

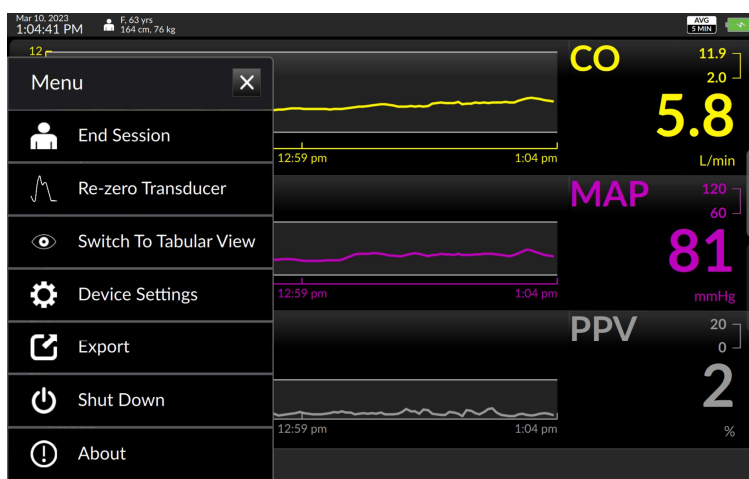

Fig. 5-82: The User Menu

5.11.3 End Session

Select End Session from the User Menu. This will bring up a confirmation screen.

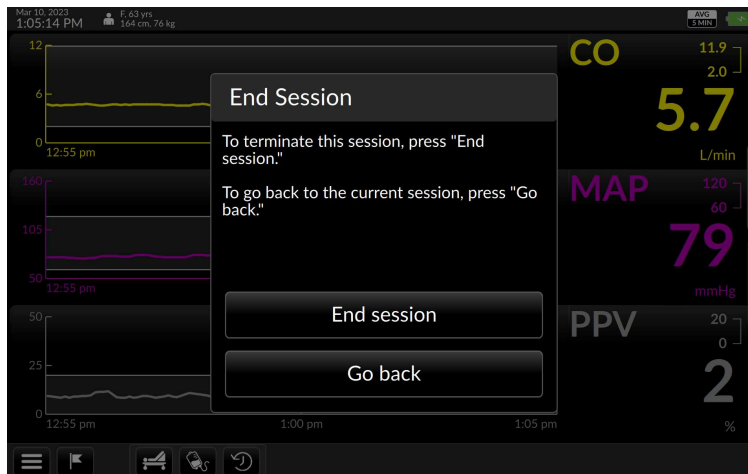

Fig. 5-83:End Session confirmation screen

To end the current session press End Session as directed by the screen. This will allow the monitor to begin a new monitoring session with a new patient.



WARNING

Never start monitoring from "Use previous patient" unless the user has verified that the patient is the same patient as monitored immediately beforehand. Always carefully check that each value of the patient's demographic information is correct before proceeding with monitoring. If monitoring a new patient, use the User menu to call up the End Session to end the session for the current patient, then a new patient screen will be presented.

The Add Patient Data screen will appear. Follow the instructions for the Add Patient Data screen (§5.5, page 54).

If the user wishes to continue with the patient being monitored, press *Continue with current patient*, as directed.

5.11.3.1 Re-Zero Transducer

If the patient is connected directly to a transducer and need to re-zero the transducer, selecting *Re-Zero Transducer*



Will take the user to the Zero transducer screen:

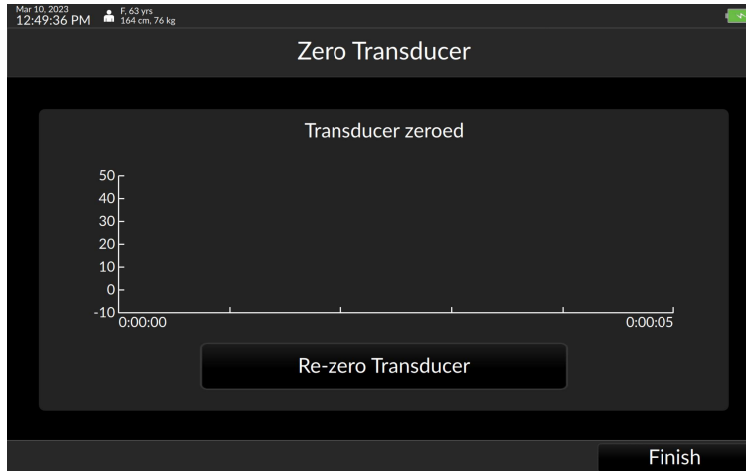

Fig. 5-84: Re-zero transducer screen

Refer to the Zero transducer screen section of this manual (§4.5, page 32) for guidance.

5.11.4 Export



Patient monitoring data can be exported to a USB drive via the Export Data menu. Plug a USB drive into one of the Argos's USB ports. Then from the User Menu, select Export to bring up a list of saved monitoring sessions.

Patient ID	Gender	Age	Start Time
555571	Female	81	Mar 13, 2023 11:19:46 AM
722516	Male	56	Mar 13, 2023 11:19:20 AM
927775	Female	89	Mar 13, 2023 11:18:53 AM
221564	Female	44	Mar 13, 2023 11:18:15 AM
22156	Male	23	Mar 13, 2023 11:17:06 AM
22214	Female	67	Mar 10, 2023 2:42:31 PM
22213	Male	88	Mar 10, 2023 1:07:31 PM
22212	Female	63	Mar 10, 2023 12:48:23 PM
400991	Male	53	Mar 10, 2023 12:42:57 PM

Fig. 5-85: Export data

Sessions are listed chronologically, identified by Patient ID number. The user identifies the patient and session they wish to export, tap it to select it, insert a formatted USB drive into one of the Argos's data export ports, and press *Export*.

Patient ID	Gender	Age	Start Time
VisitID6	Male	58	Jan 04, 2021 4:27:11 PM
22145	Female	32	Dec 17, 2020 8:30:44 PM
22145	Female	32	Dec 07, 2020 12:16:22 PM
78	Female	98	Dec 07, 2020 12:11:15 PM
78	Female	98	Nov 24, 2020 9:43:39 AM
78	Female	98	Nov 20, 2020 11:41:10 AM
78	Female	98	Nov 17, 2020 3:12:13 PM
78	Female	98	Nov 16, 2020 2:07:33 PM
78	Female	98	Nov 11, 2020 2:17:07 PM

Fig. 5-86: Tap the Export box

During the export process a *Please wait* message pops up.

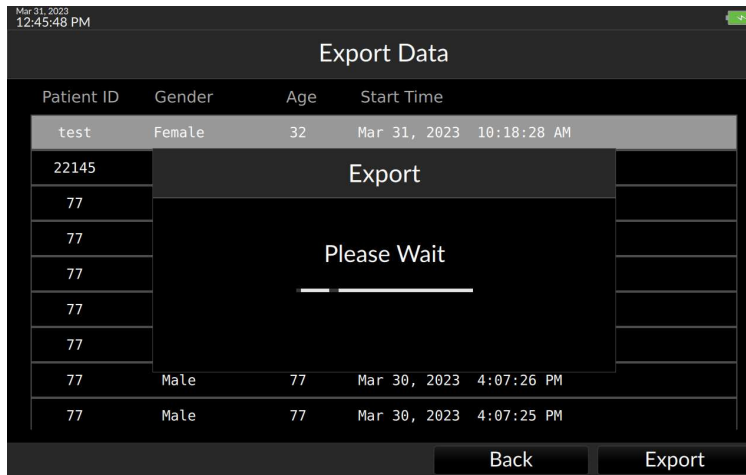

Fig. 5-87: Exporting confirmation popup

If a USB drive is not inserted, an error message appears:

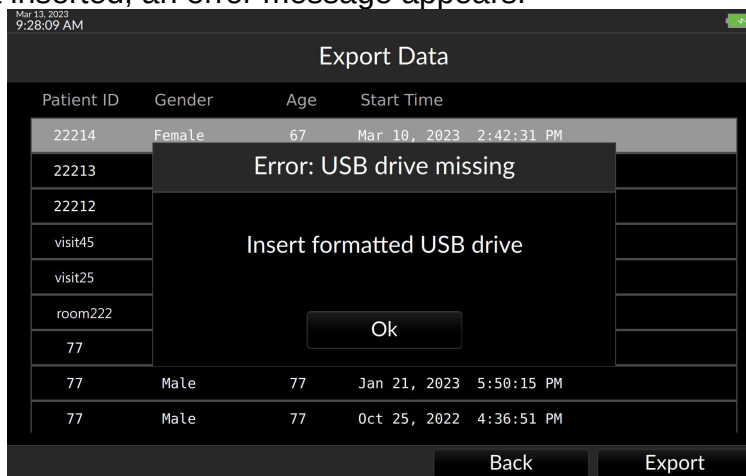

Fig. 5-88: Insert a formatted USB drive

Insert a USB drive as directed, and press OK to continue. Once the Export data screen returns, data has been successfully exported, and the USB drive may safely be removed. Press *Back* to return to the Trend screen.

5.11.5 Shut Down



WARNING

Only power off the Argos Monitor using the Shut Down function from the User Menu.
Never power off the monitor by pressing the power switch or unplugging the device.

Upon device shutdown patient data is retained for export via the data export port. (For directions on exporting data, see §5.11.4, page 91.)



Pressing *Shut Down* brings up a confirmation prompt

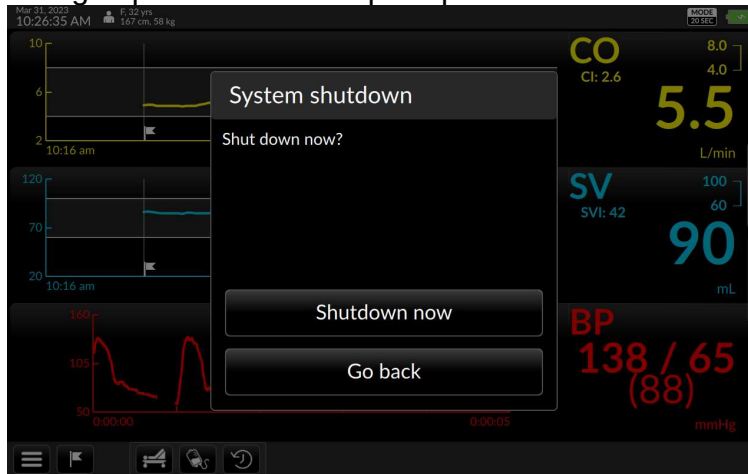

Fig. 5-89: Confirm shutdown

Press *Go Back* to resume monitoring, or *Shutdown* to end the session and turn the Argos off.

5.11.6 About

Select *About*



to view firmware and software version information.

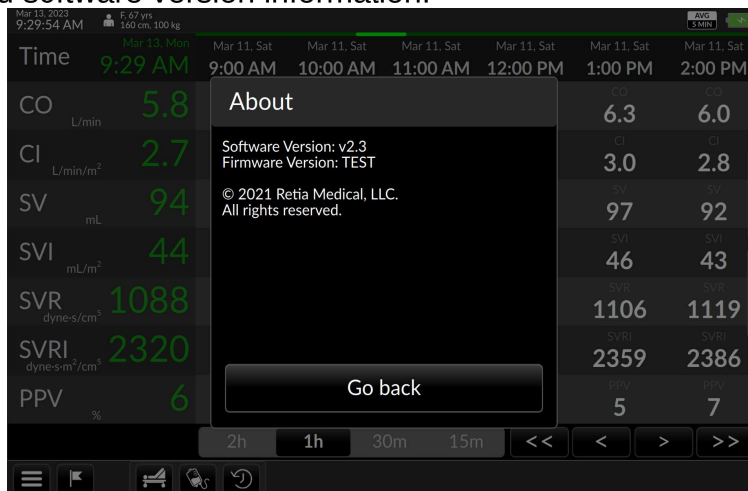

Fig. 5-90: The About screen provides software and firmware information

Licensed versions show the days remaining until license expiration and licensee information.



Fig. 5-91: About screen (Licensed versions)

The About page will indicate if any of the EMR licenses have expired.



Fig. 5-92: EMR software licenses have expired

5.11.6.1 Device Settings

Selecting *Device Settings*



Brings up the Settings menu

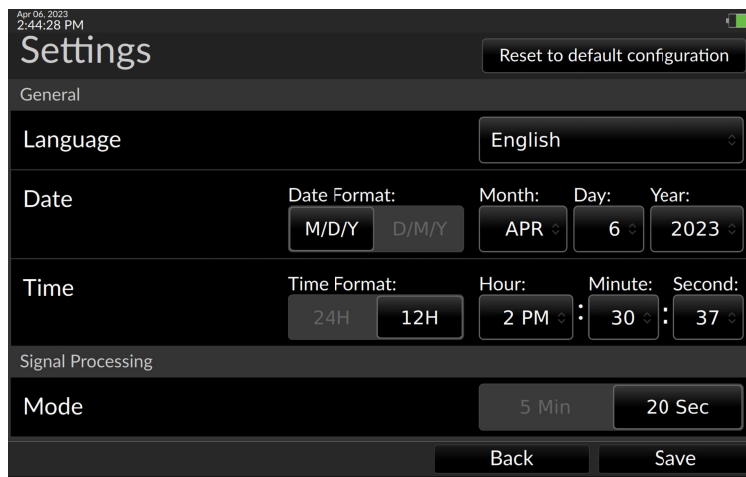

Fig. 5-93: The Settings menu, top

Touch and drag the screen or pull down the scroll bar on the right edge to bring the bottom of the Settings menu into view

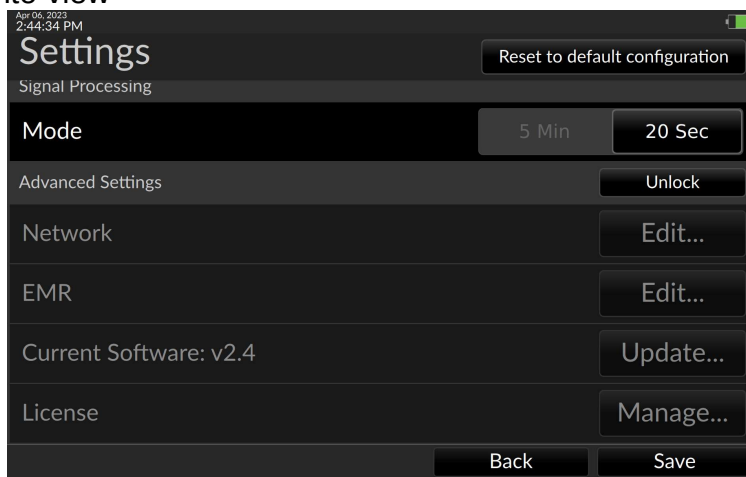

Fig. 5-94: The Settings menu, bottom

- *Date and Time, and Advanced settings cannot be changed during a patient monitoring session.*

5.11.6.2 Reset to default configuration

To return all device settings to factory defaults, press *Reset to default configuration*:

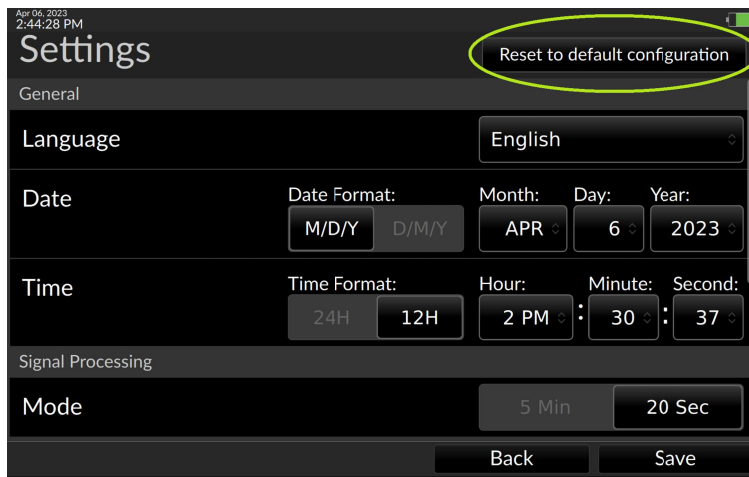

Fig. 5-95: Reset to default configuration selector

A confirmation screen appears:

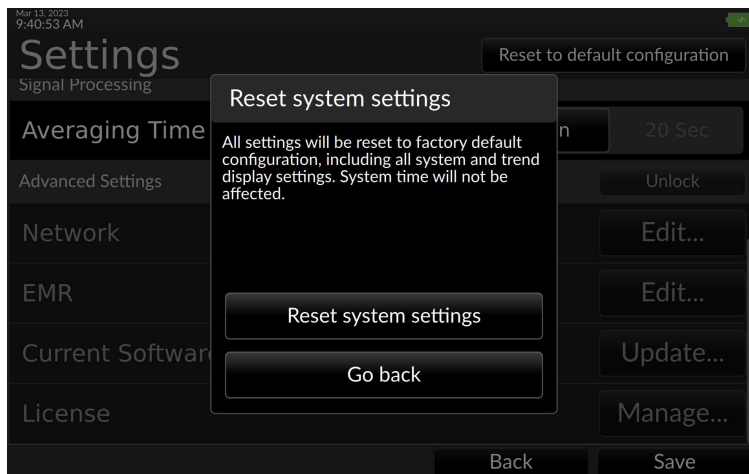

Fig. 5-96: Confirm reset to defaults

Confirming will reset all settings (except for system time) to factory defaults: including Trend selections, colors, display choices, parameter limits, graph ranges, time scales, and units.

Press *Reset System Settings* to reset to factory defaults. If the user does not wish to reset the device, press *Go back*.

5.11.6.3 Language, Date, and Time

The Language, Date and Time settings can be changed. (Languages other than English will be available in the future.)

**CAUTION**

Time and Date cannot be changed while a patient is being monitored.

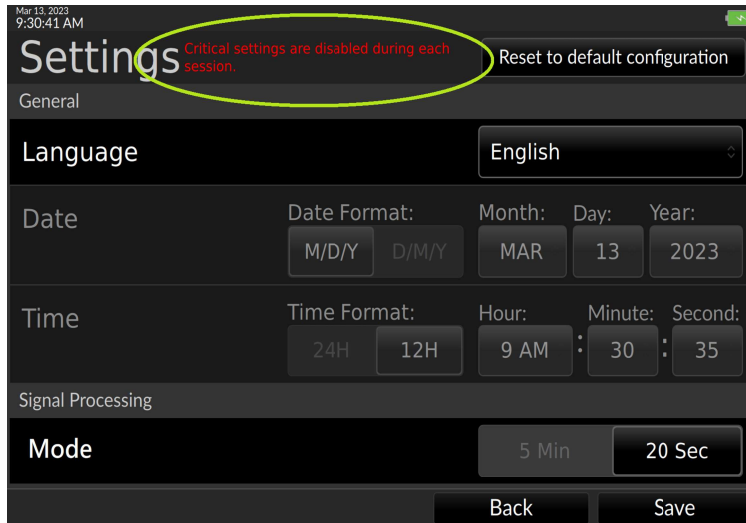

Fig. 5-97: The Settings menu (during patient monitoring session)

5.11.6.4 Monitoring Mode

The Argos offers two monitoring mode options, 5 minutes or 20 seconds. For both options, the display of each parameter value is a rolling average that is updated every 5 seconds. In the case of the 20 second option, rapid changes in the patient's hemodynamics will be reflected more quickly in the updated parameter display, whereas with the 5-minute option, hemodynamic changes will be reflected over a longer period of time. When monitoring the effect of an intervention, the user should take note of the selected monitoring mode.

After choosing the desired monitoring mode, press Save to return to the Trend Screen.

5.11.6.5 Advanced Settings

Advanced Settings allow the user to

- Configure the Argos EMR interface (Electronic Medical Record) compatibility for use with a particular EMR system
- Manage the software license key to enable purchased software options
- Perform software upgrades

**CAUTION**

Advanced Settings including License Management and Software Upgrade are designed to be implemented by Retia trained personnel in conjunction with the facility's IT department. Users should not attempt to change these settings. IT personnel should be trained by Retia and consult the relevant sections of this manual before accessing these settings.

Advanced Settings are a feature of Argos software versions 2.00 and above. Users of earlier versions should contact their Retia representative to upgrade the software on their monitor. By default, Advanced Settings are locked. The software key needed to unlock Advanced Settings is available with a service contract. Only a Retia trained representative may install the software key.

Step-by-step guidance for configuring Advanced Settings are found in §7, Software Management.

5.11.6.6 Events

The Argos permits user notation and recollection of events via the Events popup on the Control Bar. To access Events, press the flag icon:



Fig. 5-98: Tap the flag icon to notate or recall events

The Events page appears with the Mark Event tab selected. A virtual keyboard allows entry into a text box, with the current time for logging the entry. Adjusters permit changing the marked time.

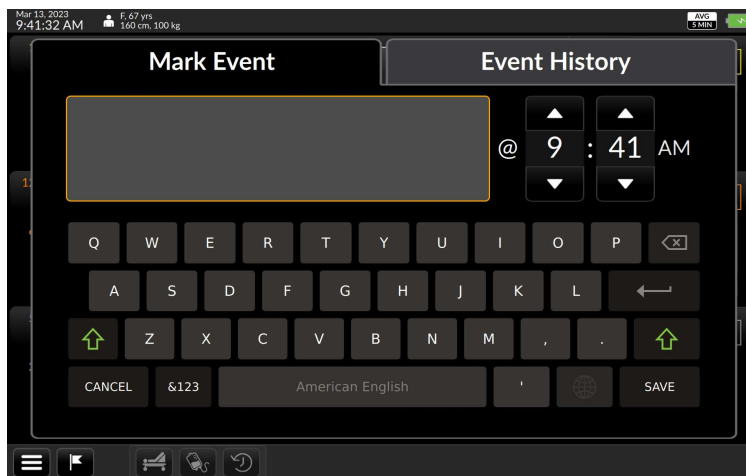

Fig. 5-99: Event marking screen, with Mark Event selected

Use the keyboard to describe the event. If the user needs to notate an earlier time, adjust the time using the triangle buttons.

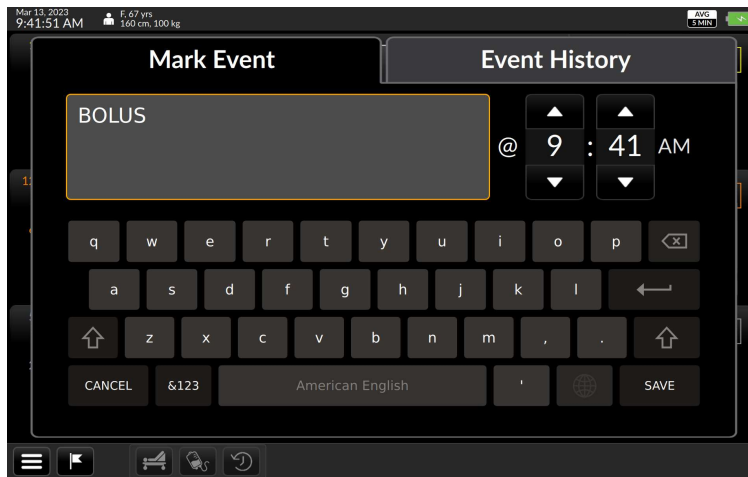

Fig. 5-100: Description of event

To save the event text, press Save. The Trend screen resumes.
 To recall events, press the Event History tab. All saved events appear in chronological order.

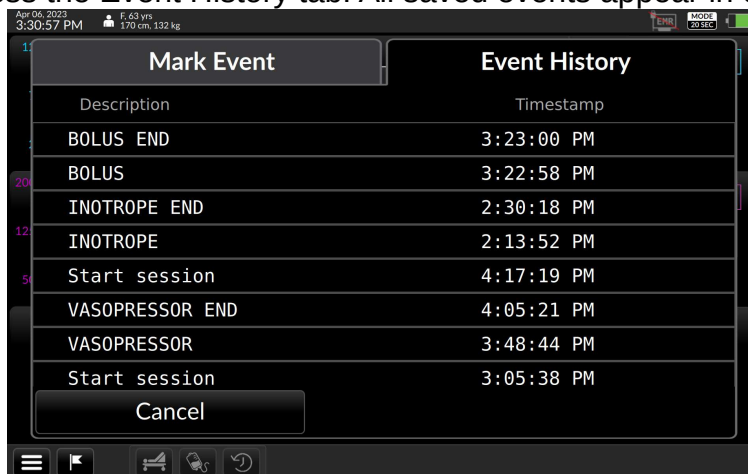

Fig. 5-101: The Event History tab

To edit an event, touch it in the chronology line. The *Event: Edit Event* screen appears:

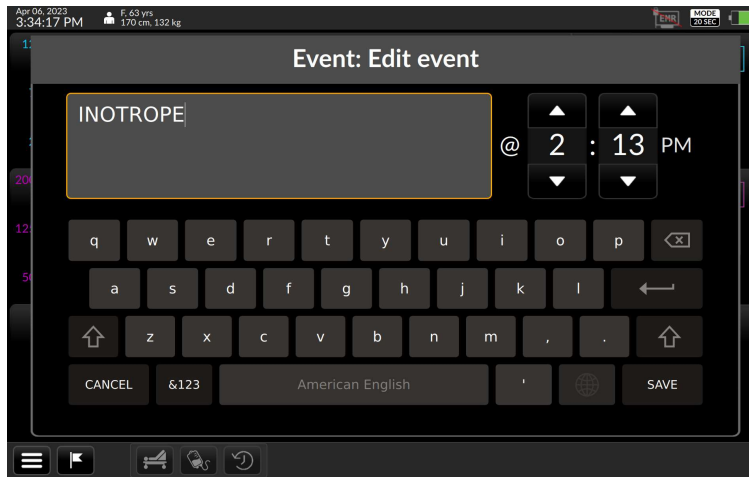

Fig. 5-102: Edit event

Here the user may alter text, adjust Event Time as desired, or use the keyboard to make changes. Press Save to commit the changes.

To return to the Trend screen from the Event History overlay, press Cancel. Flags representing the marked events appear on the trends.

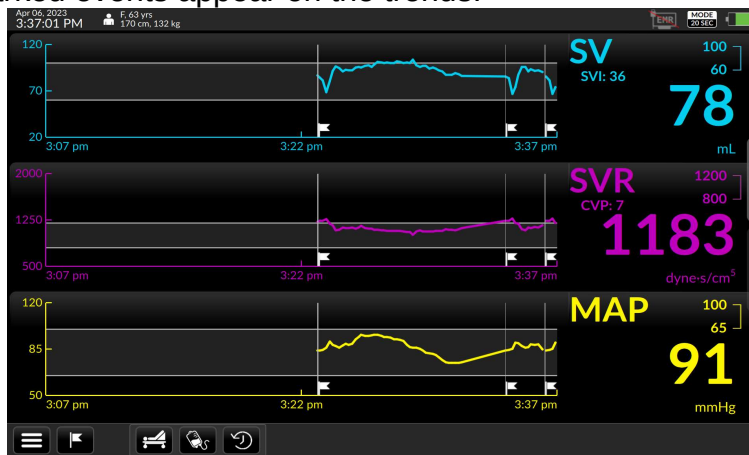

Fig. 5-103: Press cancel to recall the Trend screen

5.12 Dynamic Assessment Functionality

The Dynamic Assessment feature guides the Clinician through a sequence of steps, providing instructions throughout the process to determine if a patient is likely to be fluid responsive or not. It consists of two stages. The first stage establishes a baseline. The second stage examines how SV changes after an intervention. The Dynamic Assessment feature guides the clinician through these stages, providing instructions throughout the process.

5.12.1 Assessment types

The Argos supports two types of Dynamic Assessments:

- 1) a Passive Leg Raise (PLR).
- 2) a Fluid Bolus.

5.12.2 Canceling an Assessment

Once the user begins a fluid challenge. The user will not be able to switch between the challenge screen and the trend screen. The monitor will still be running in the background and the previously chosen parameters will always still be visible.

However a Challenge can be canceled at anytime.

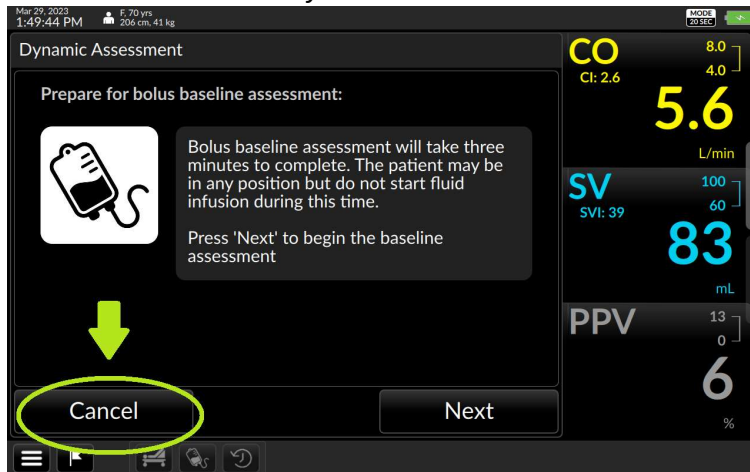

Fig. 5-104: Press cancel to end assessment and go back to trend screen.

If the user creates a baseline, but does not complete the assessment, an entry will be added to the Dynamic Assessment history showing an aborted challenge. If the user does not finish establishing a baseline, an assessment record will NOT be saved. To see more on the DA History go to section 5.12.5

5.12.3 Fluid Bolus Assessment

The fluid bolus icon can be found on the bottom of the Control Bar. Press this icon to begin the Dynamic Assessment using fluid bolus.

7.7.5.1.2

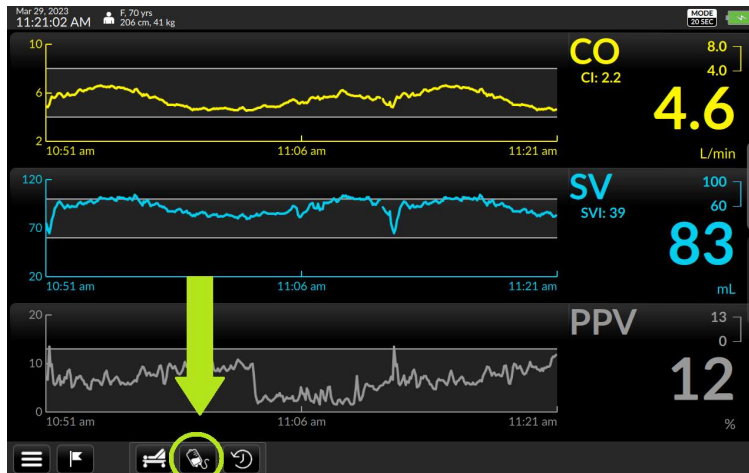

Fig. 5-105: Press the fluid bolus icon to start the challenge.

The user can choose between a 250ml bolus or a 500ml bolus.

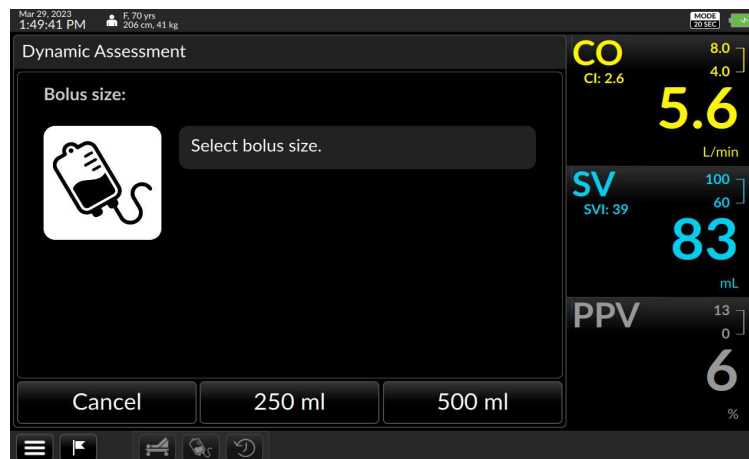

Fig. 5-106: Select between the two bolus sizes.

If the Argos does not have an existing baseline, the user will be brought to a screen that gives instructions on how to create a new baseline. When ready to begin the baseline, press "next".

- Note the Argos is always calculating a rolling baseline of the patient in the background, so sometimes the Argos will already have a qualified baseline for the patient. If it does, the next screen will give the option to create a new baseline or use the baseline that was calculated in the background.

The user begins by selecting the desired bolus size to continue. Press Next to create a new baseline.



CAUTION:

Once the user begins a fluid challenge, the user will not be able to switch between the challenge screen and the trend screen. The monitor will still display the parameters that have been previously selected. The trend screen cannot be accessed unless the Dynamic Assessment challenge is canceled. A challenge can be canceled at anytime.

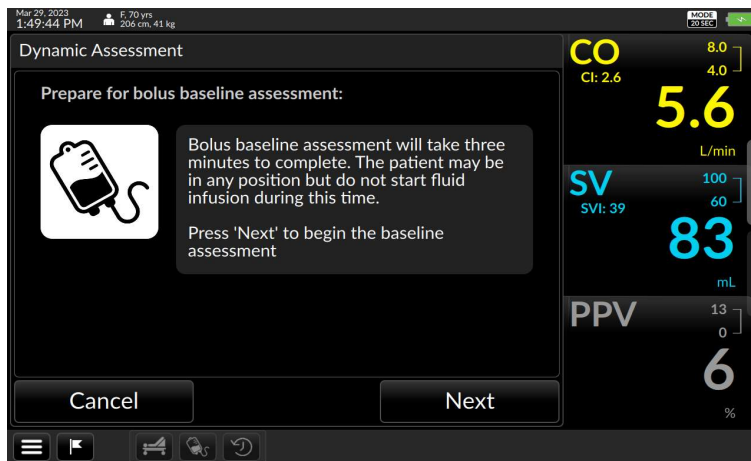

Fig. 5-107: Argos prompts to create new baseline.

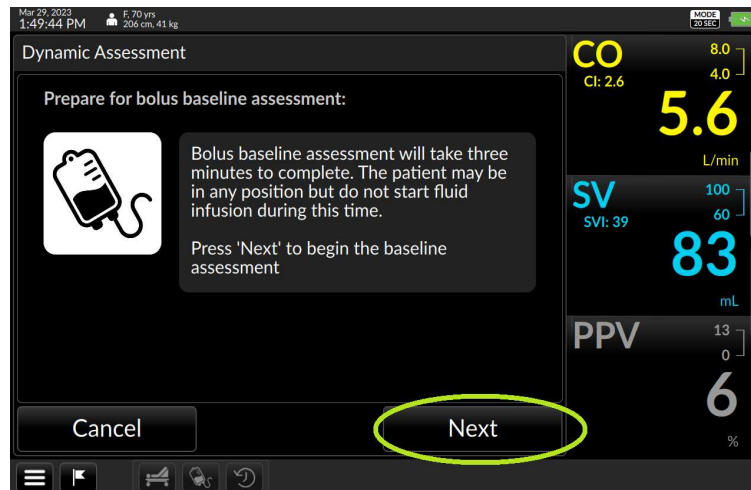

Fig. 5-108: Press Next to create new baseline.

A 3 minute timer will begin counting down. When the timer completes, a new baseline has been captured and the user will be brought to the challenge preparation screen.

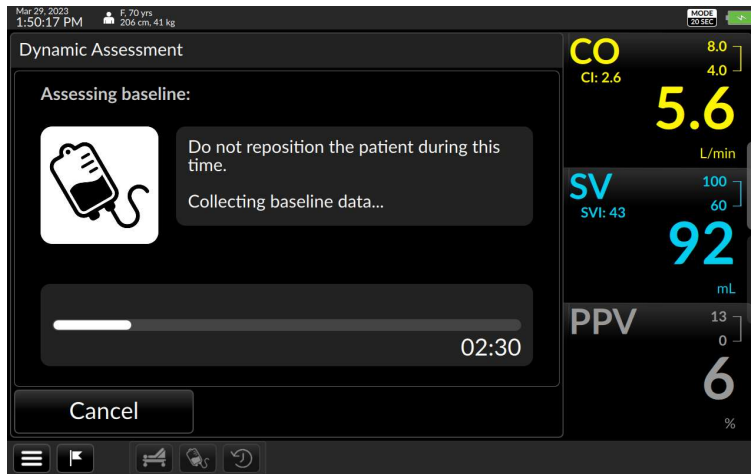

Fig. 5-109: 3 minute timer countdown to create baseline for bolus fluid assessment.

When the timer has finished the baseline is complete and the begin infusion screen will be presented.

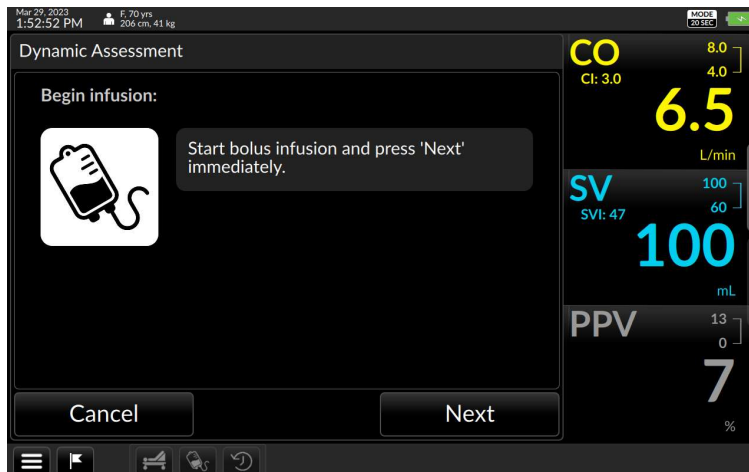

Fig. 5-110: Begin 250ml or 500ml Bolus infusion.

When the user is ready to begin the challenge, start the bolus infusion and immediately press *next*.

CAUTION: Please ensure that the patient remains still to prevent the occurrence of an unstable baseline. For more information on unstable baselines, see section on unstable baselines.

A countdown timer will begin and the percent change from the baseline to the current SV reading will be displayed on the screen. When running a 250ml bolus, the countdown timer will run for 7 minutes.

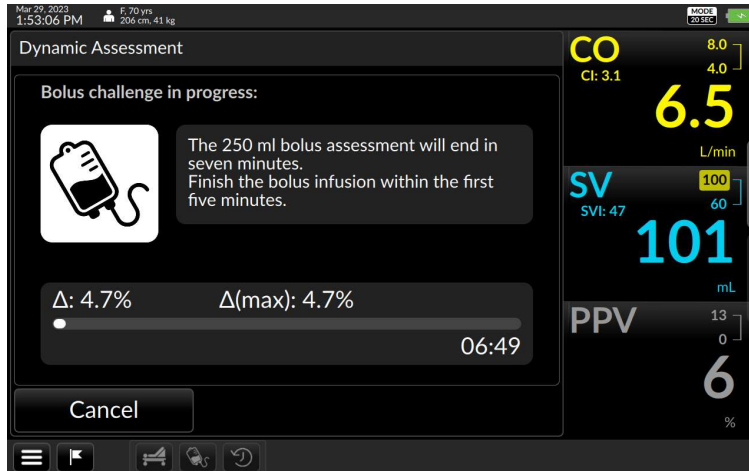

Fig. 5-111: 7 minute timer countdown for a 250ml bolus

A 500ml bolus will count down for 12 minutes.

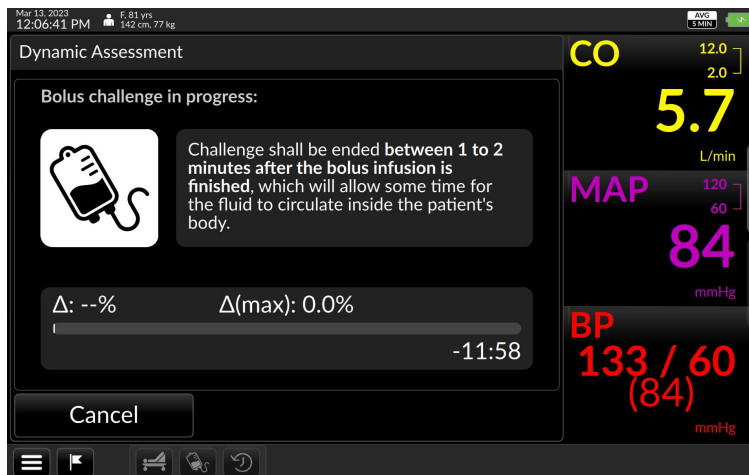

Fig. 5-112: 12 minute timer countdown for a 500ml bolus

If the percent change is equal to or greater than 10%, the assessment will end and show the report screen.

- Note that if ΔSV never reaches 10%, the countdown timer will continue until it reaches zero. When the timer reaches zero, the report screen will appear and show a likely non-responsive result.

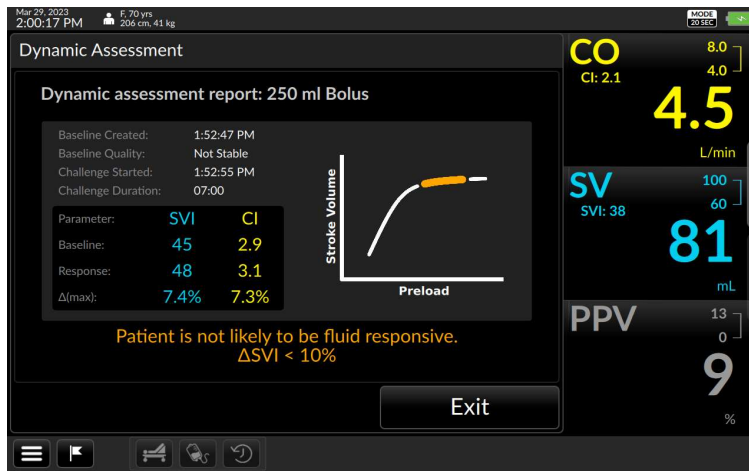

Fig. 5-113: Report shows that patient is not likely fluid responsive.

5.12.4 Passive Leg Raise (PLR) Assessment

A Passive Leg raise assessment or a PLR is a noninvasive method to assess fluid responsiveness by raising the patient's legs 45°.

The Passive Leg Raise (PLR) icon can be found at the bottom of the Control Bar.



Fig. 5-114: Dynamic Assessment, PLR icon located on the Control Bar.

Once the User clicks on the PLR icon, the user will be brought to an instruction screen which will describe how to prepare the patient for a PLR baseline.

- Note the ARGOS does not maintain a rolling baseline in the background when doing PLRs. The patient needs to be moved into the correct position before capturing the baseline.

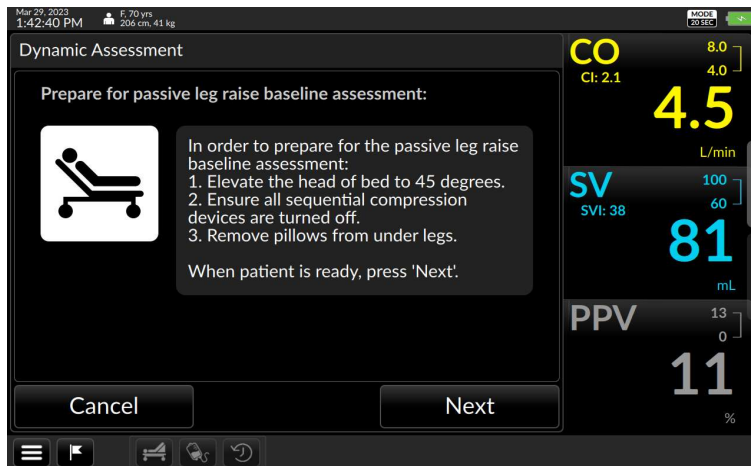

Fig. 5-115: Instruction screen to prepare patient for PLR assessment.

Once the patient has been positioned for the baseline, press *Next* to begin acquiring the baseline for the Passive Leg Raise Assessment.

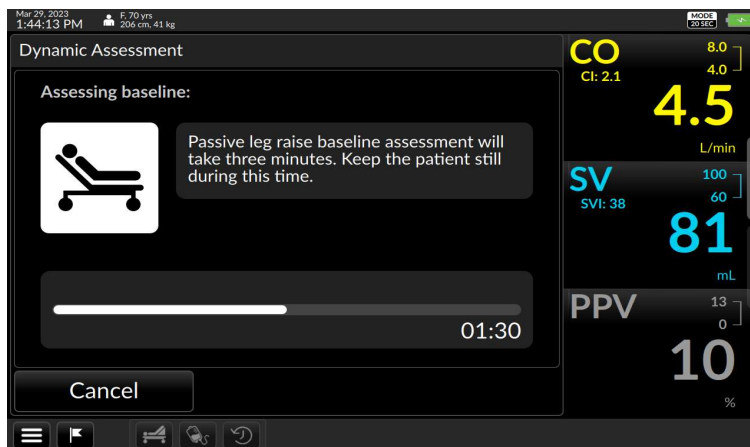

Fig. 5-116: 3 minute countdown timer to measure baseline for PLR assessment.



CAUTION: Please ensure that the patient remains still to prevent the occurrence of an unstable baseline. For more information on unstable baselines. See Baselines

When the 3 minute timer has finished and a baseline has been acquired, the challenge screen will appear.

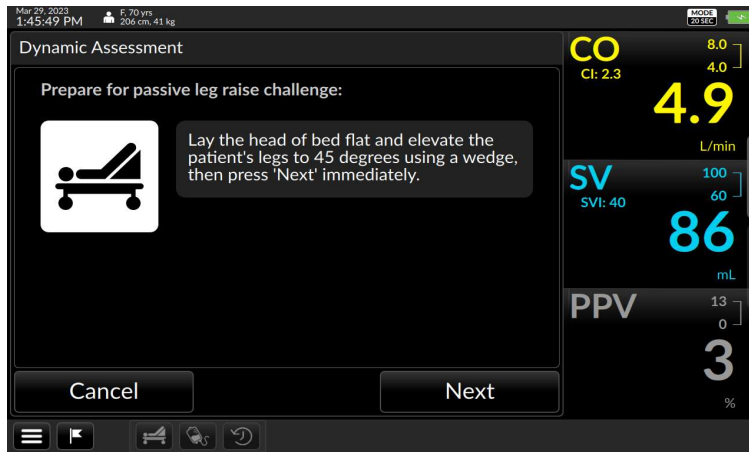

Fig. 5-117: Instruction screen to inform the user to raise patient's legs by 45°

Once the patient's head of the bed is flat and their legs have been elevated by a wedge to 45°, the user should immediately press *Next* to begin the Passive Leg Raise Assessment. The Argos will display a 3 minute countdown timer. The screen displays the percent change between the baseline and the current SV reading and the maximum percent change observed during the challenge.

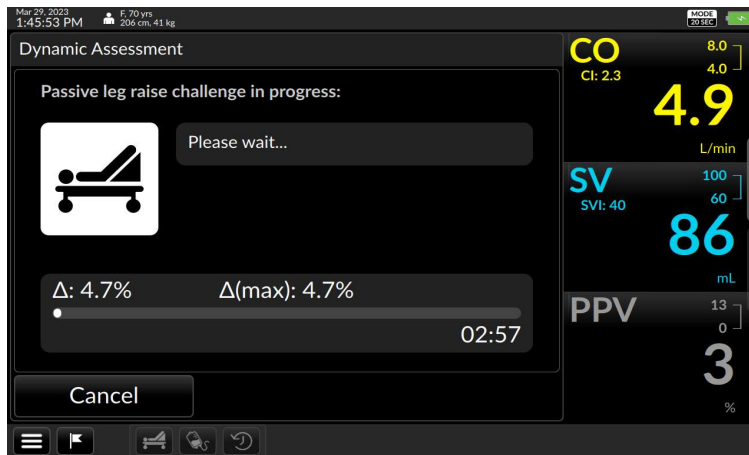

Fig. 5-118: PLR challenge screen which takes no more than 3 minutes.

If ΔSV is greater than or equal to 10%, the challenge will end immediately, and show a report screen indicating that the patient is likely fluid responsive.

If ΔSV remains below 10% for the whole three minutes, the challenge will end and show a report screen indicating that the patient is likely not fluid responsive.

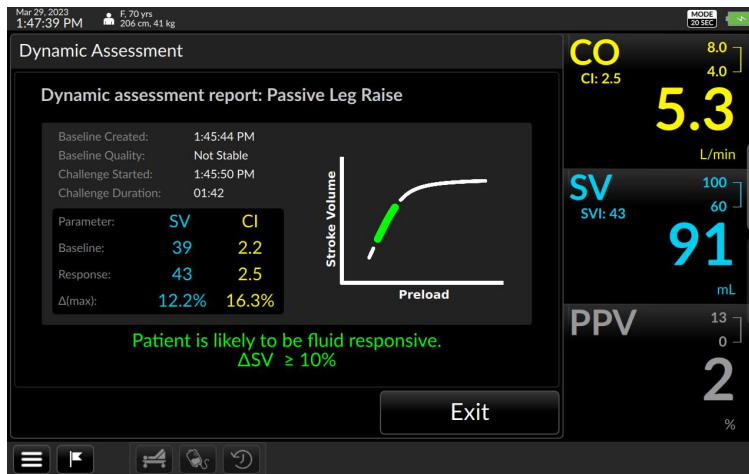

Fig. 5-119: PLR challenge screen reports that patient is likely fluid responsive.

5.12.4.1 Baselines

Baselines are calculated by taking the average of 3 minutes of data. The Argos categorizes baseline quality into four categories: stable, unstable, invalid, and expired. For technical details on how baselines are categorized please see Table 15

5.12.4.2 Unstable Baseline

If the patient's Stroke Volume (SV) is rapidly fluctuating or the patient is unable to keep still during the Bolus or PLR baseline assessment. The Argos will inform the user that the Baseline is unstable. This could potentially cause the Fluid responsiveness assessment to be inaccurate.

If the Argos detects an unstable baseline, it will notify the user and ask if the user wants to use the unstable baseline or establish a new one.

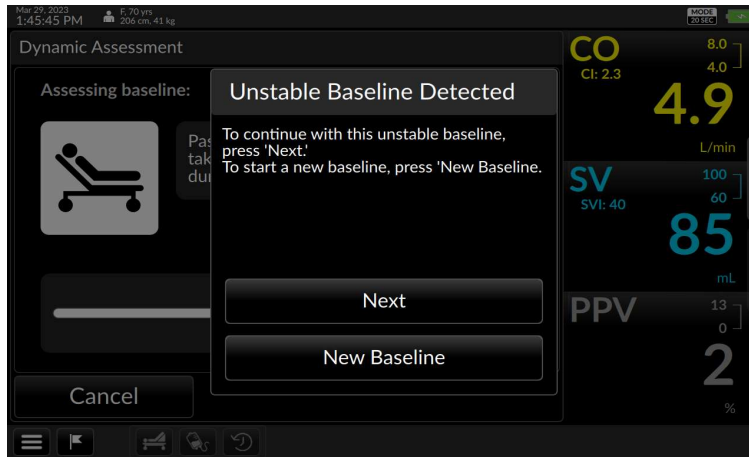

Fig. 5-120: Argos lets user know that the baseline is unstable.

The monitor is continuously maintaining the statistics for the baseline. If a period of time has elapsed and the baseline is no longer stable, then the user will be prompted to establish a new baseline by pressing *New Baseline*.

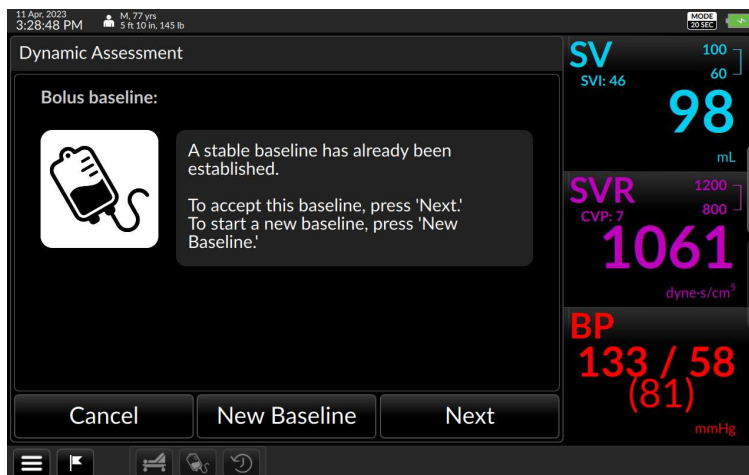

Fig. 5-121: Argos gives the user the option to use the existing baseline or to create a new one.

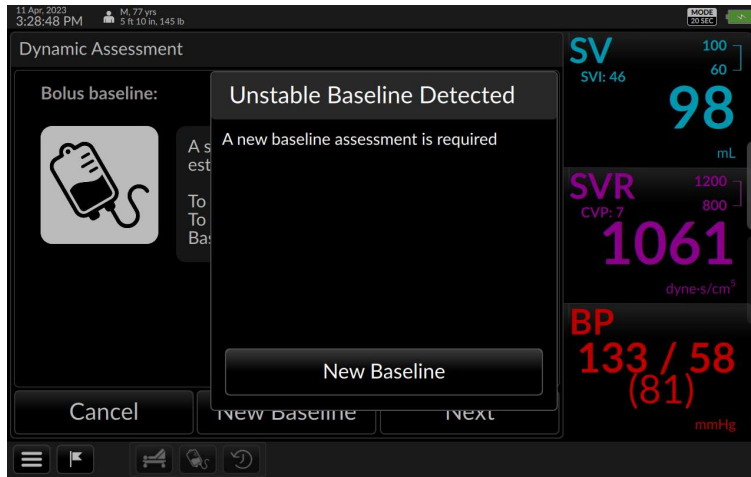

Fig. 5-122: Argos prompts user to manually create new baseline.

5.12.4.3 Invalid Baseline

If during baseline collection, the Argos is unable to obtain enough valid SV samples, a baseline is considered invalid. Invalid samples can occur if the BP signal is lost or there are fluctuations that prevent the monitor from gathering enough data to calculate SV.

Invalid samples are ignored when calculating percent change. If during the challenge there is no sample above the 10% threshold, the number of invalid samples is counted. If the challenge has been more than one third invalid samples, the result is considered invalid.

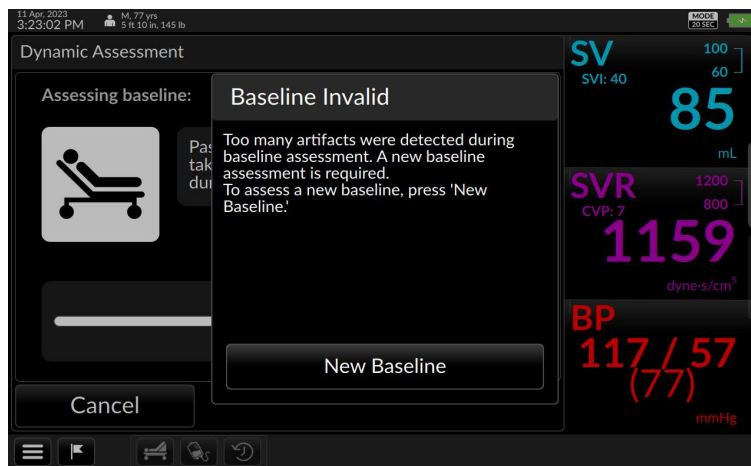

Fig. 5-123: Baseline rejected due to invalid samples

**CAUTION!**

Invalid samples are excluded from the average. If more than one third or 1 minute of the samples collected for calculating the baseline are invalid, the baseline will be considered invalid.

If the monitor shows that there is invalid data, the user should insure the BP waveform is artifact free and that the connection from the Argos monitor to the patient monitor is stable. Rerun the baseline.

5.12.4.4 Expired Baseline

To maximize the quality of a dynamic assessment, the baseline and challenge stages should be run as close to each other as possible. An old baseline is less likely to accurately represent the resting state of the patient when the intervention is made. To ensure that the user does not accidentally use an old baseline, after 15 minutes the monitor will prompt the user to either establish a new baseline or agree to use the existing baseline.

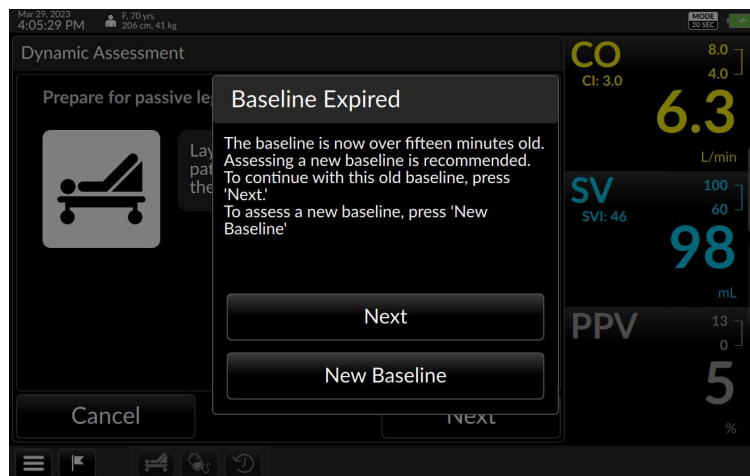

Fig. 5-124: Monitor prompts user that it's baseline has expired since their baseline is over 15 minutes old.

5.12.5 Dynamic Assessment History

The Dynamic Assessment History icon allows the user to view all Dynamic Assessments from the current session. To access the Dynamic Assessment History screen, press the Dynamic Assessment History icon on the Control Bar.

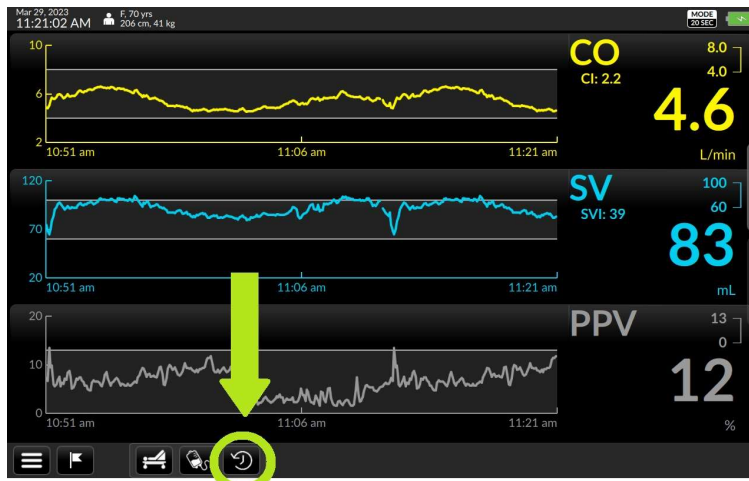

Fig. 5-125: Dynamic Assessment History Icon can be found on the Control Bar.

To view more information on previous assessments, tap on any of the previous dynamic assessments listed to expand it.



Fig. 5-126: Dynamic Assessment History performed during this session.



Fig. 5-127: Dynamic Assessment History entry expanded to show more details.

Table 5: Dynamic Assessment History Headers

Label	Description
Date	Date when the Dynamic Assessment was run
Challenge Type	Type of challenge. Can be PLR, Fluid Bolus 250, or Fluid Bolus 500
Baseline Quality	Indicates the quality of the baseline. (Notes if the baseline was stable, unstable, invalid, or expired)
Challenge Begin	At Time when the challenge began
Duration	Length of the challenge
ΔSV	Percent change of SV from the baseline to the maximum value observed during the challenge
Challenge Result	Result of the Challenge. Can be responsive, not responsive, or invalid

5.13 Date and Time indicator

Date and Time cannot be changed during a monitoring session.

5.14 Patient Demographics

Choose between metric and imperial when adding the patient during initial setup.

Patient information cannot be changed during a monitoring session.

5.15 EMR indicator (*licensed versions*)

Configured Argos monitors with a licensed upgrade show an interactive EMR status indicator at the top right of the screen beside the monitoring mode indicator.

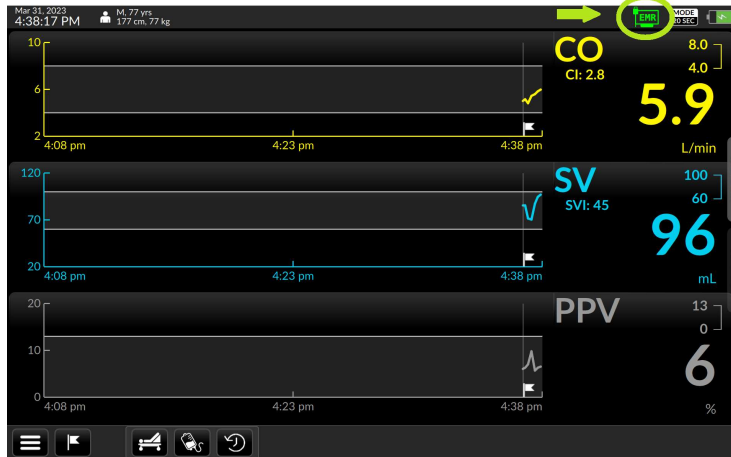

Fig. 5-128: EMR indicator

Table 6: EMR status icons

EMR Status	Icon
EMR connectivity normal	
Cannot connect to server	
Network unavailable	

Hold the EMR indicator to display a popup with further information:

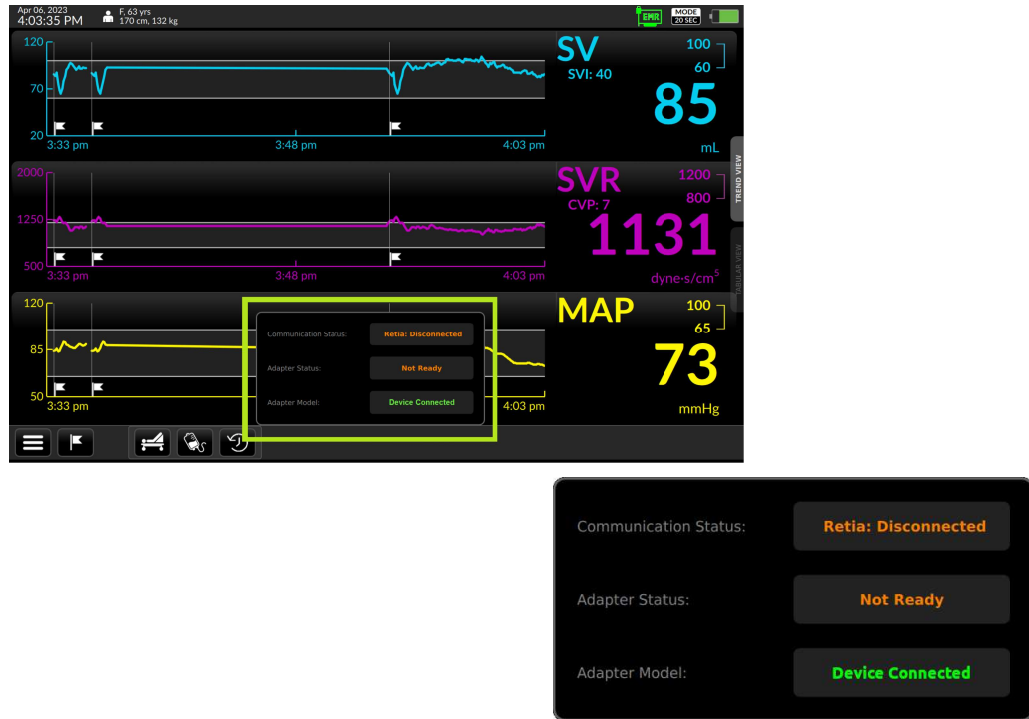

Fig. 5-129: EMR connectivity details

Release to dismiss the popup.

More information on EMR connectivity is detailed below in §6, p. 119, **EMR Integration**.

5.16 Monitoring Mode of Operations

Default monitoring mode is 20 seconds. Monitoring mode may be changed to 5 minutes in the Settings page (see §5.11.6.4, p.98).

5.17 No Signal Detected timeout

In order to prevent accidentally continuing a previous patient's monitoring in the event the previously monitored patient was not discharged from the monitor and a new patient installed, after 30 minutes of the absence of a blood pressure signal, the Argos software will notify the user of the absence of a BP signal:

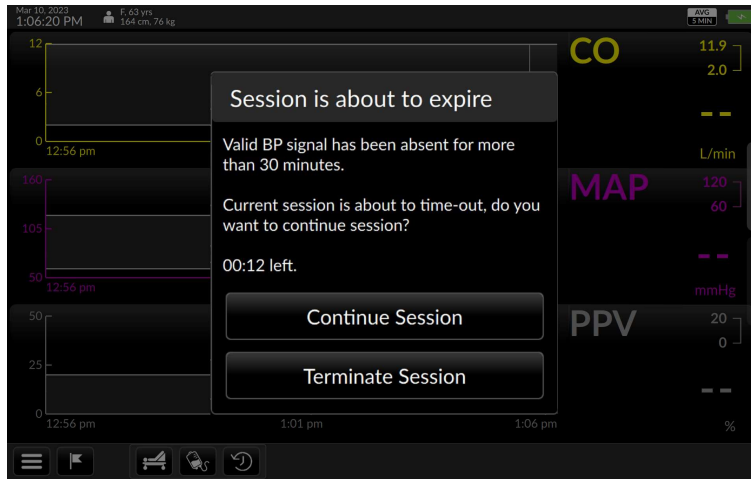

Fig. 5-130: No BP signal detected warning

If the notification has not been acknowledged after an additional 30 minutes, the software automatically stops recording to the database and discharges the patient, and the monitor returns to the Enter Patient Data screen (§5.5). This ensures if a new patient is admitted to the Argos monitor the associated demographic information will reflect only that patient's data.

6 EMR (Electronic Medical Records)

Integration

Hemodynamic data collected by the Argos monitor can be delivered to an electronic medical record keeping system. This feature is available with a software license.

- ↳ *The Argos can download patient demographic data from a Corepoint server.*
- ↳ *To date the monitor has been configured to send data to a Philips Capsule server, Masimo (formerly Nant Health) server and the Philips Intellivue Monitor.*
- ↳ *When EMR capability is being used, it is the operator's responsibility to enter the correct Patient ID to ensure continual updating of the EMR database. In case of error or interruption of the EMR connection, the Argos will continue updating monitoring records locally.*

Since the Argos monitor uses industry standard HL7 protocols for communication, it can be configured to work with compatible systems. Because software development may be required, please consult with a Retia Medical representative when planning an installation into the hospital's Electronic Medical Records (EMR) system.

Hardware Requirements:

EMR integration requires the Argos LAN Connectivity Kit (p/n FG-008) which provides for connection of the FG-001 Argos Monitor to the local area network (LAN) within a hospital, allowing the Argos Monitor to communicate with EMR servers and transfer hemodynamic data on a minute-by minute basis.

- **FG-008:** Network Connectivity Kit with Ethernet adapter and network galvanic isolator with cabling. (For interfacing with the Capsule or Masimo data interfaces.)
- **FG-009:** Serial Connectivity Kit with cabling (For interfacing with the Philips EC10 monitor interface)

Information on updating and configuring the Argos software to enable communication with EMR systems is available in §7, Software Management.

6.1.1 Entering Patient Data (*Licensed Version - Corepoint*)

If the device license has been activated (§7.1.1) and Corepoint data server connectivity has been configured correctly (§7.4.1.1), the Add Patient Data screen offers a patient search box

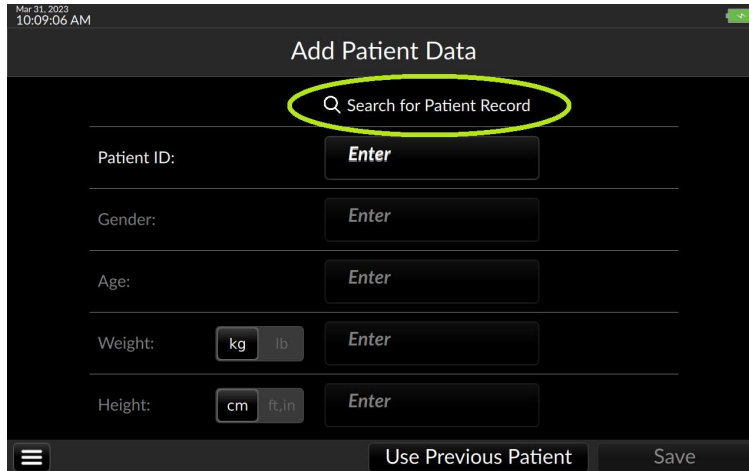

Fig. 6-1: Add Patient Data screen with Search for Patient Record

Touching inside the search box brings up an alphanumeric keyboard.

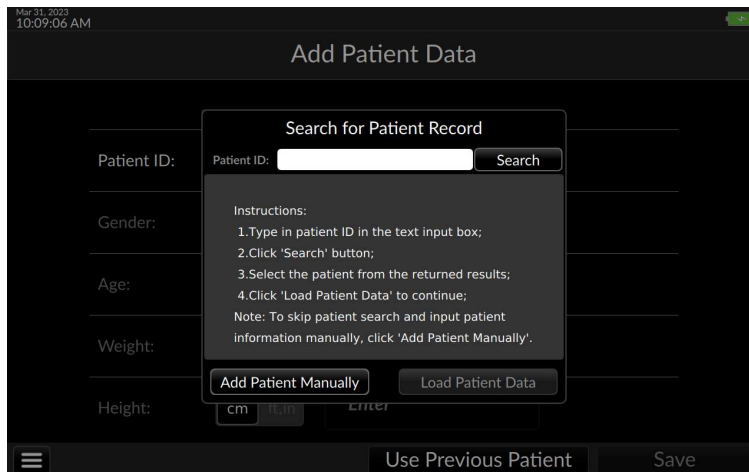

Fig. 6-2:Patient record search

Key in the patient ID assigned by the hospital, then press Search, or the return button on the virtual keyboard

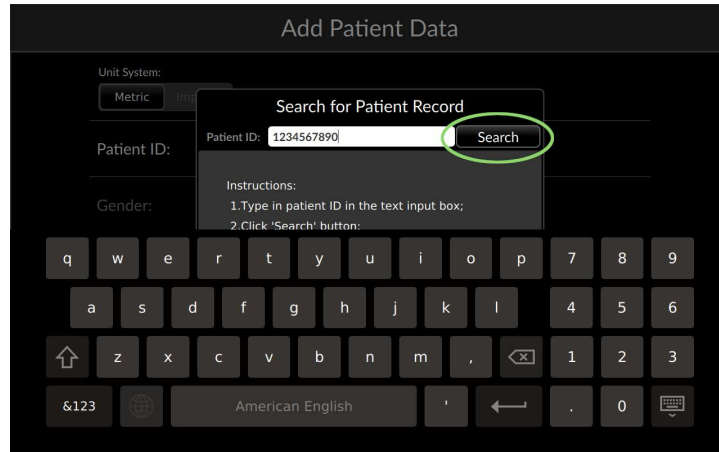

Fig. 6-3: Press Search after typing in the patient record

When the Patient ID is found, the record appears

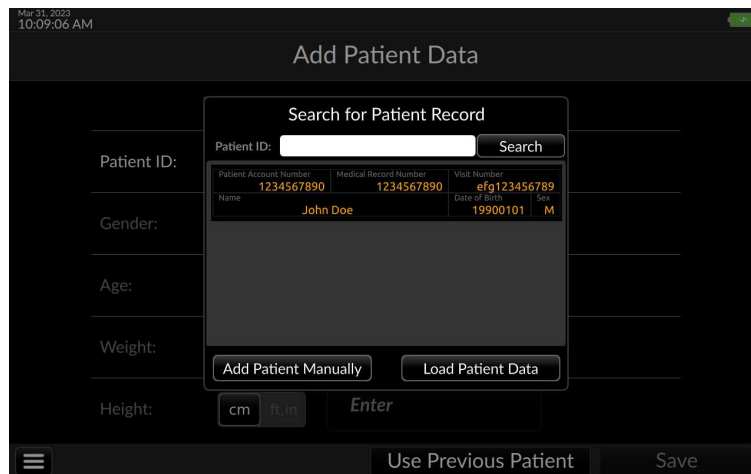

Fig. 6-4: Patient record located

Touch the Load Patient Data button. The Argos connects with the patient record database in order to confirm the patient's identity and details as input are correct.

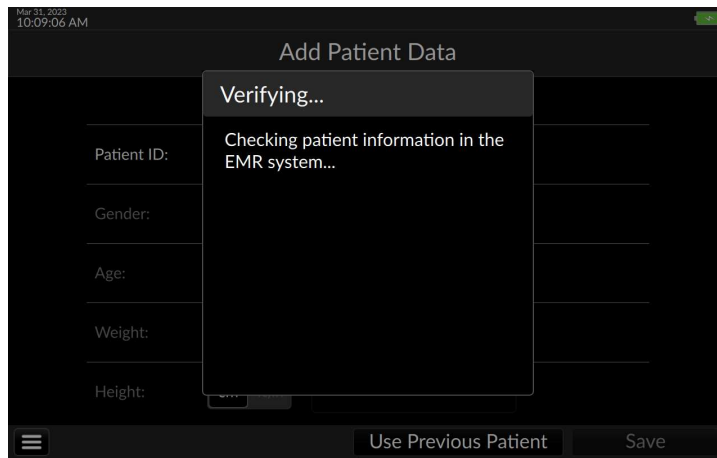

Fig. 6-5: Verifying patient details with the EMR server

Patient ID, Gender, and Age are shown on Add Patient Data screen. Verify the patient demographic information is correct.

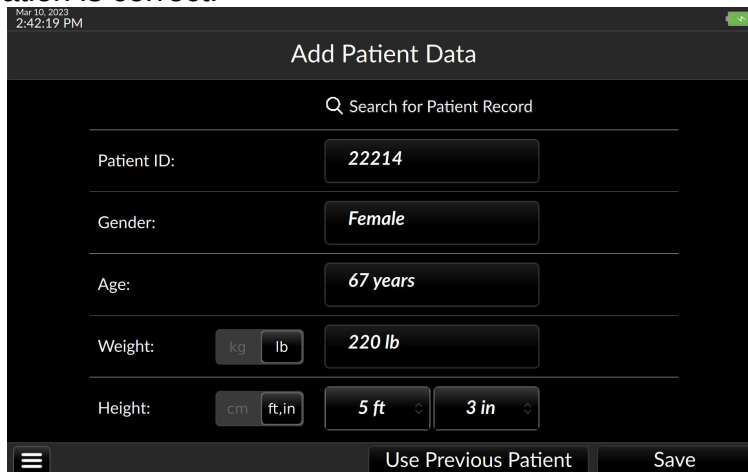

Fig. 6-6: Add patient weight and height, then press Save

Once Save is pressed, the Select Blood Pressure Signal Source screen appears. Monitoring may be initiated following selection of the signal source.

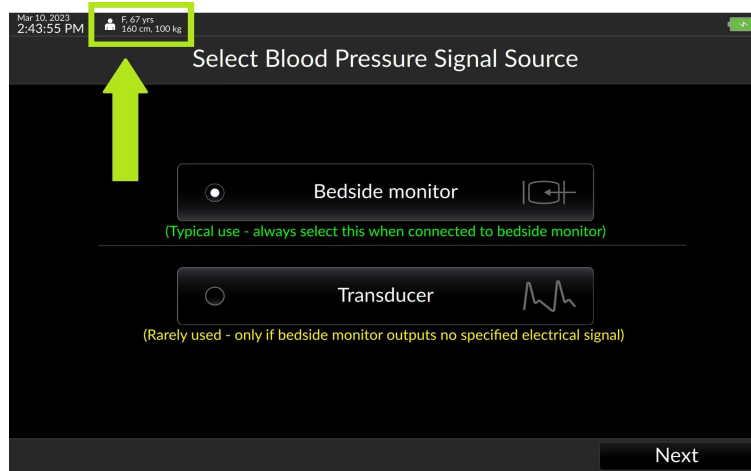

Fig. 6-7: Patient demographics loaded, ready to proceed with monitoring

If no Patient ID is found in the Corepoint database, or there is no connection to the server, a popup offers the choice between saving the previously entered patient ID to the Add Patient Data page or starting over with a new search

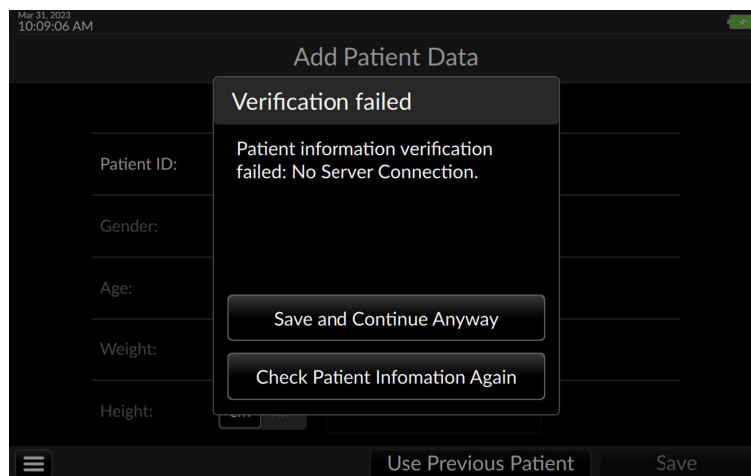

Fig. 6-8: Patient verification failed

If the search fails again after the operator has entered all the patient's ID and demographic information manually, pressing Save and Continue Anyway will save the manually entered information locally to the device and allow for monitoring without delay.

7 Software Management



CAUTION

Advanced Settings including License Management and Software Upgrade are designed to be implemented by Retia personnel in conjunction with the facility's IT department. Users should not attempt to change these settings. IT personnel should be trained by Retia and consult the relevant sections of this manual before accessing these settings.

7.1 Activating Advanced Settings

Advanced Settings allow Retia authorized personnel to:

- Install the licensed version of the Argos software
- Enable (or disable) and configure EMR (Electronic Medical Records) integration for licensed monitors, including network settings (*Licensed devices only*)
- Update the Argos software

To activate Advanced Settings, first open the Settings screen from the menu icon (§5.11.6.1, p. 95). Swipe up the center of the screen or use the slider bar on the right side of the screen to show the Unlock button to the right of “Advanced Settings.” Note that if Advanced Settings are locked, settings entries below it are dimmed.

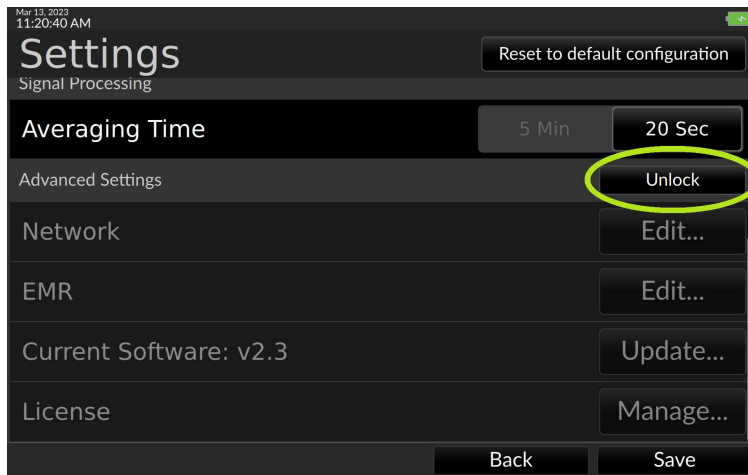

Fig. 7-1: Touch Unlock to open Advanced Settings

Touching Unlock brings up a confirmation screen

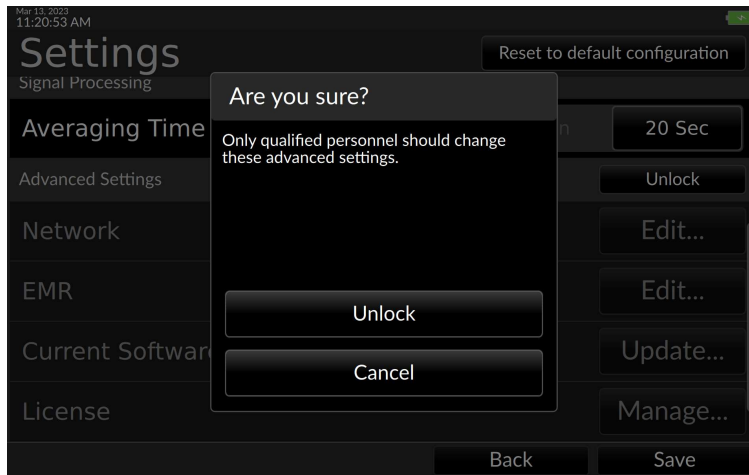

Fig. 7-2: Confirm the user is qualified to change Advanced Settings

Confirm by pressing Unlock. The Advanced settings screen opens.

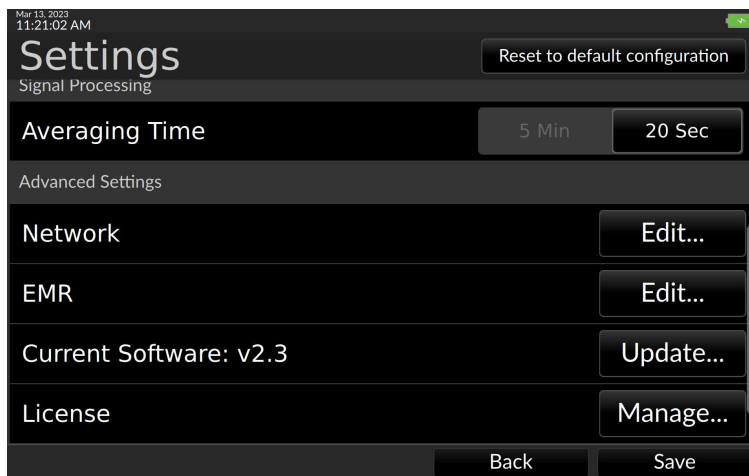

Fig. 7-3: Advanced settings, top of screen

7.1.1 Installing the software license to enable EMR

EMR connectivity requires a software license key provided by a Retia representative. This license enables an Advanced Settings screen for configuring EMR interoperability.

- *The software license can only be installed on Retia Argos monitors using software version 2.00 or later. If the monitor uses any 1.XX version, contact Retia to upgrade the system software.*

7.1.2 Verifying the software license has been installed

To verify whether the device is licensed to enable EMR connectivity, navigate to the Advanced Settings page: open the Settings screen from the menu button on the far lower left of the screen and swipe up the center of the screen or use the slider bar on the right side of the screen to show the “Advanced Settings” title next to the “Unlock” button:

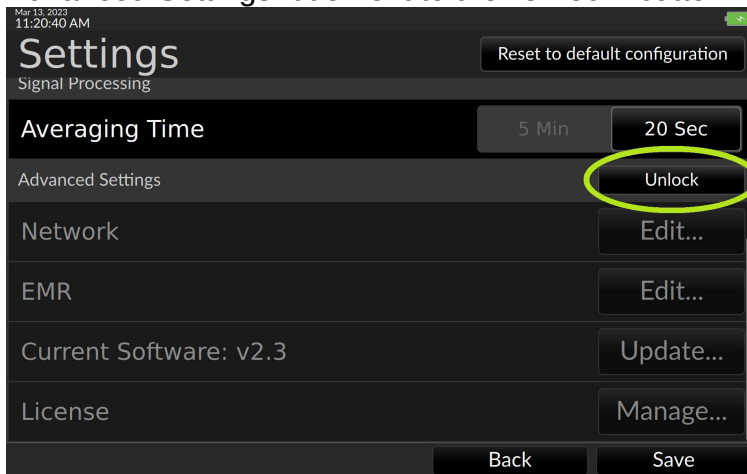

Fig. 7-4: Press Unlock to access Advanced Settings

Press the unlock button. A confirmation screen appears.

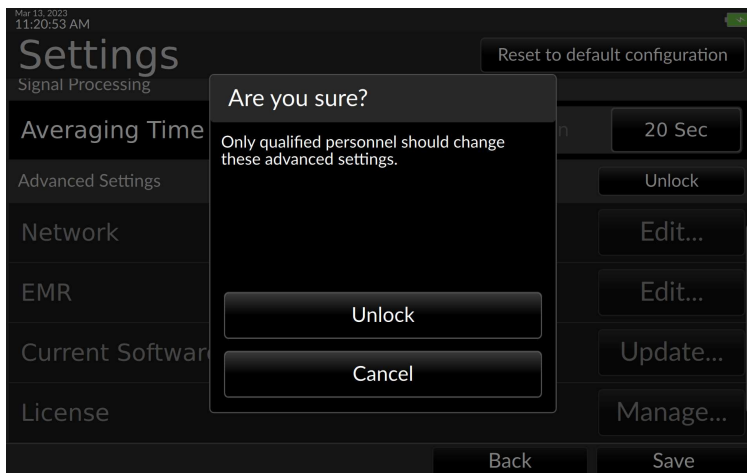

Fig. 7-5: Confirm access to Advanced Settings

Once Advanced Settings have been enabled, settings are undimmed. Press the Manage button to the right of the License entry:

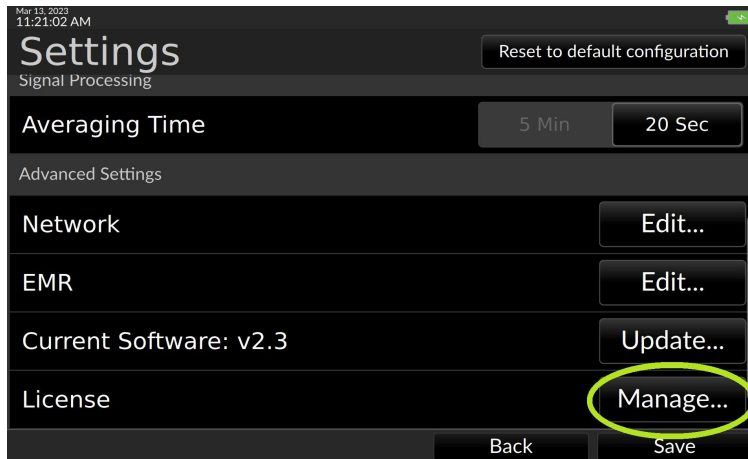

Fig. 7-6: Press Manage to verify EMR status

If licensed, the popup displays license details

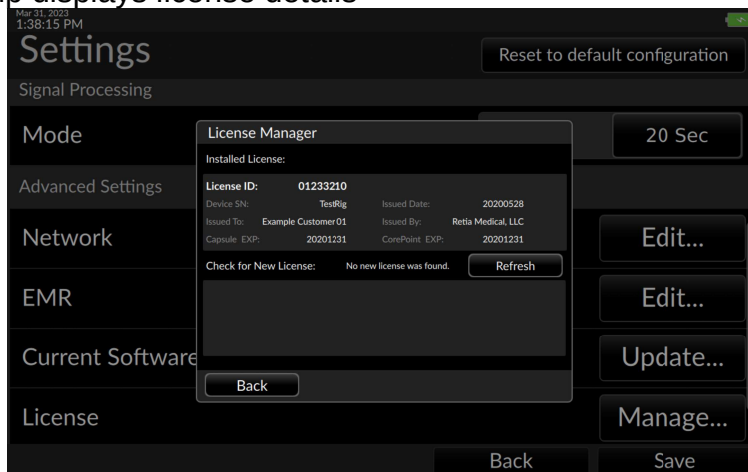

Fig. 7-7: License Manager display of licensed device information

If the device is not presently licensed and no USB license key is in the drive, the License Manager indicates Not Found

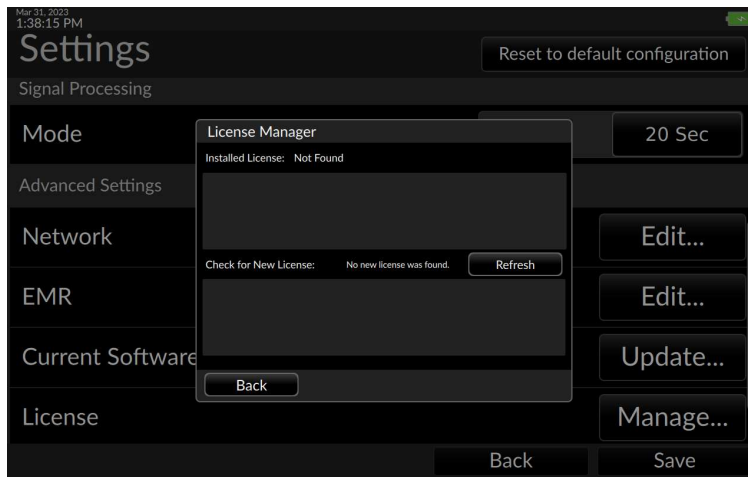

Fig. 7-8: Installed license not found

7.1.3 License installation

Insert the USB license key into one of the Argos's data ports and press the Refresh button next to the Check for New License menu entry. Details of a valid software license will show in the lower pane of the License Manager window.

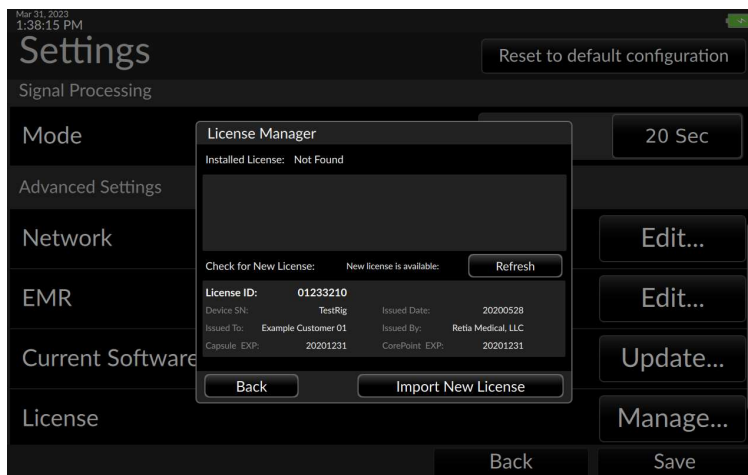

Fig. 7-9: License ready for installation from USB drive

Press "Import New License" to load the license into the Argos.

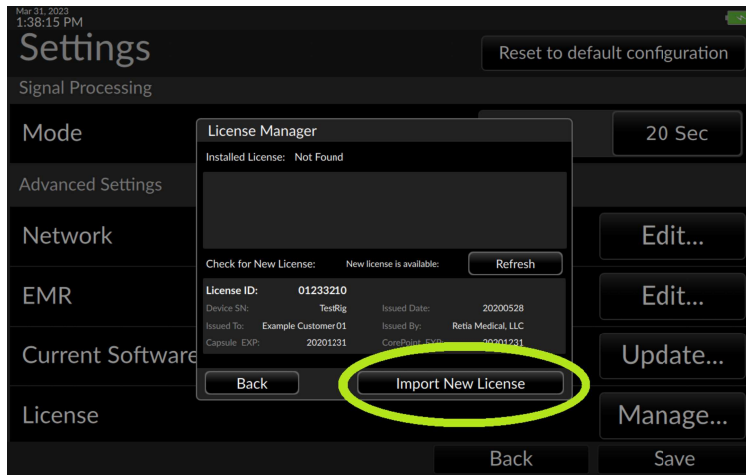

Fig. 7-10: Press Import New License

A notification that the license has been successfully imported appears.

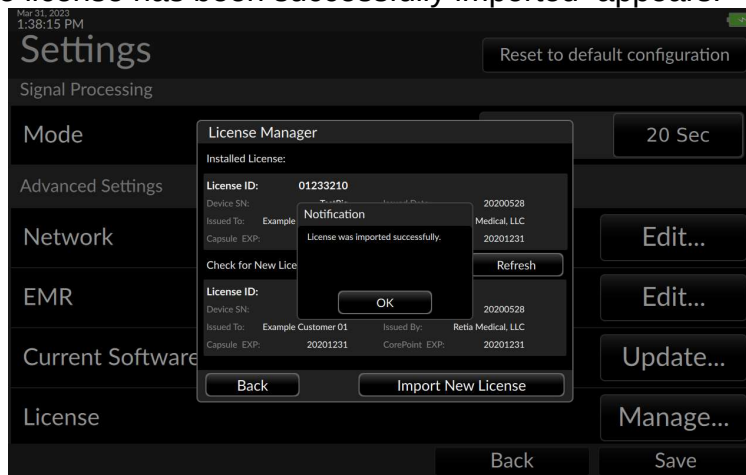

Fig. 7-11: Software license successfully imported

Remove the USB stick. To verify the license has been installed, touch Back, then from the Advanced Settings page press the License Manage... button. License details will now display in the upper panel of the License Manager popup

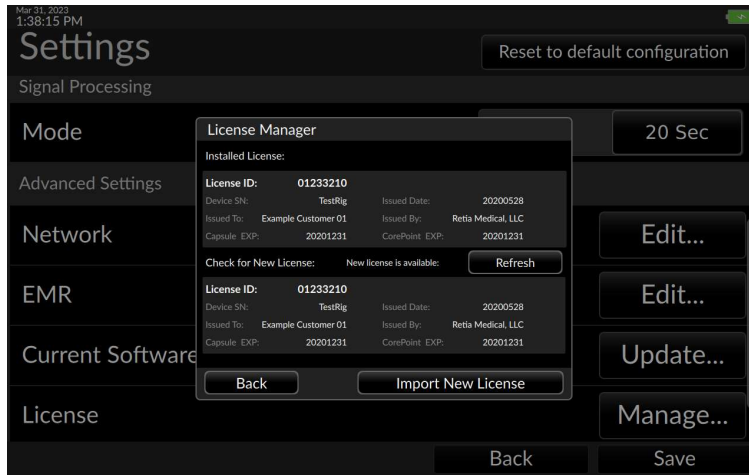

Fig. 7-12: License information displayed in License Manager

7.1.4 Configuring EMR service connectivity

EMR capability requires

- Software version 2.0 or higher
- A valid software license
- The Retia Argos LAN Connectivity Kit (P/N FG-008)
- Or:
- The Retia Serial Interface Connectivity Kit (P/N FG-009)

The Argos can connect directly to a monitor (Philips Intellivue) via a serial connection using the FG-009 Serial Connectivity Kit or to an EMR platform that resides on a TCP/IP network using the FG-008 LAN Connectivity Kit. In either case an EMR software license is required.

7.2 Philips Monitor Settings

To configure the Argos monitor for use with the Philips IntelliVue Monitor the user will need the following hardware:

- A Philips EC10 built in, or an EC10 module that supports the Philips IntelliVue Open Interface (consult a Philips representative).
- A Philips EC5 interface model number 865114 option #104 (consult a Philips representative).
- The Retia FG-009 Serial Connectivity Kit (consult a Retia representative).

From the settings screen select the EMR Edit button and select “Philips” from the drop down list and press save.

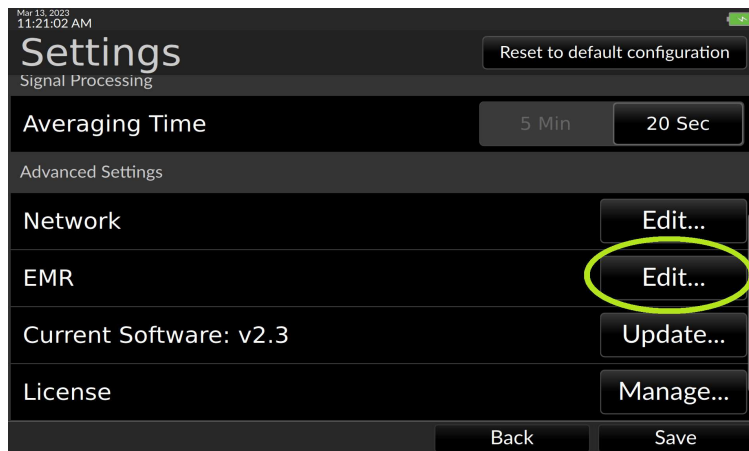

Fig. 7-13: Selecting the Philips Monitor Connection...

Once this is selected and the Philips EC5 is plugged into the Retia FG-009 and the Philips EC10 the rest is automatic. The User can verify the functional state of the connection by pressing the “EMR” button that appears on the lower right side of the Argos screen. It takes approximately one to two minutes for the connection between the Argos monitor and the Philips monitor to be established.

7.2.1 Troubleshooting the Philips Monitor Connection

If the Argos is not connected to the FG-009 the Adapter model will show “Adapter not found”. Make sure the FG-009 adapter is plugged into one of the USB ports on the side of the Argos monitor as described in the FG-009 Setup Instructions (60-037 Serial Connectivity Kit Setup Guide that comes with the FG-009).

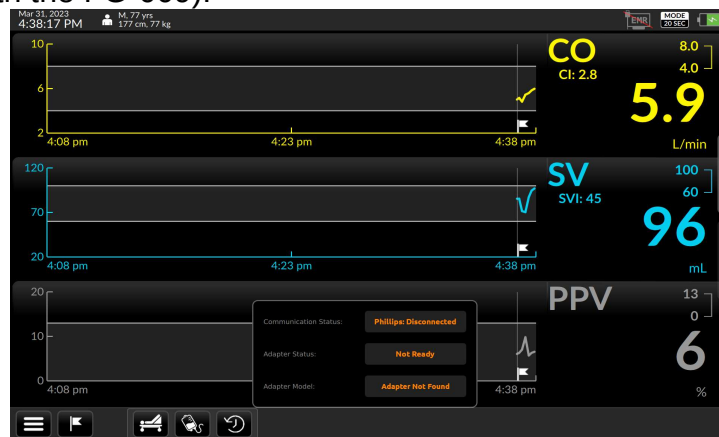

Fig. 7-14: Connection Status for Philips Monitor Showing no FG-009 Connected

Once the FG-009 is properly connected to the Philips EC5 and the Philips EC5 is properly connected to the Philips EC10 module, the user should see “Philips: Connected” in the Communication Status row as shown in figure 8-127. The user can also verify the connection

status from the EC10 module LED indicator: A blinking indicator indicates the Argos monitor is detected and communicating.

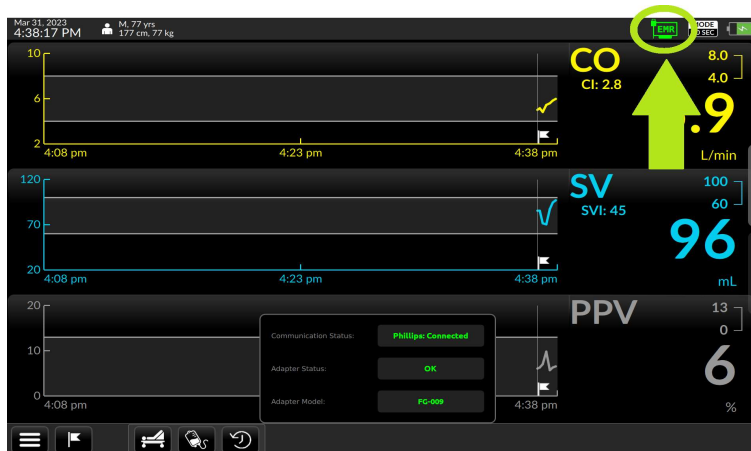

Fig. 7-15: Connection Status for Philips Monitor Showing Full Functionality

Once connected to the Philips monitor, the hemodynamic data (CO, CI, SV, SVI, SVR, SVRI, PPV) are able to be viewed on the Philips monitor as C.O., C.I., SV, SI, SVR, SVRI and PPV respectively. If connected to an EMR these variables will be sent by the Philips monitor to the EMR.

7.3 Network Settings

From the Advanced Settings window (§7.1) press Edit to the right of the Network entry in the Settings menu

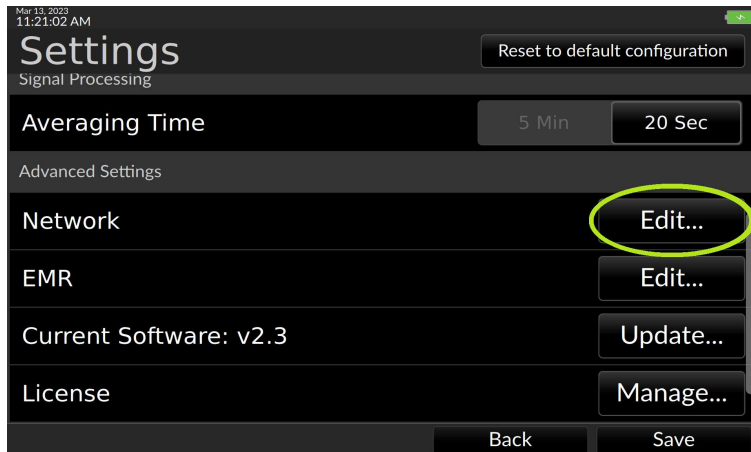

Fig. 7-16: Select Network/Edit...

The Network screen offers the choice between Automatic IP addressing (if a DHCP server is on the network) or manual addressing. Automatic IP addressing is selected by default.

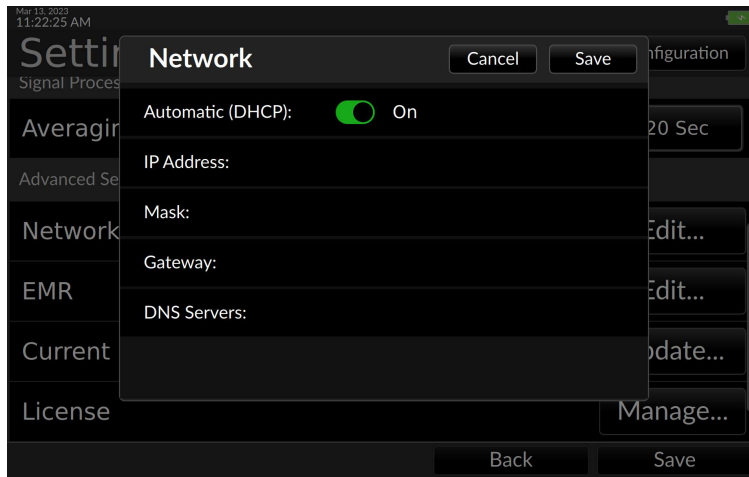

Fig. 7-17: Automatic (DHCP) addressing shown selected

If a DHCP server is present, leave Automatic (DHCP) selected. If there is no DHCP server, the user must configure network settings manually. First, move the slider button to switch off DHCP.

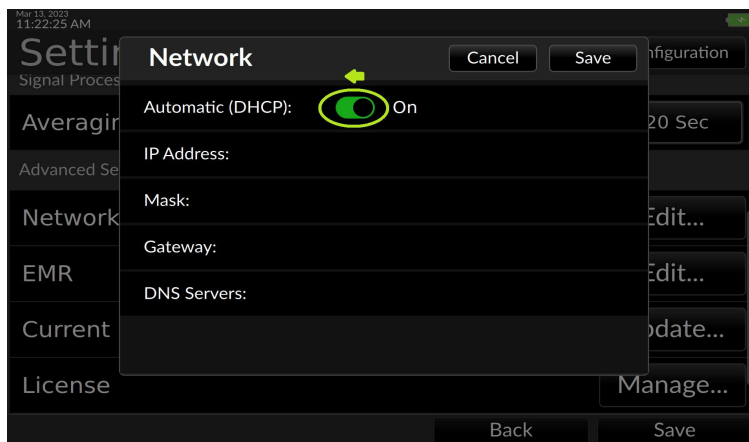

Fig. 7-18: Move the slide to switch off DHCP

The network settings will populate with sample values for editing.

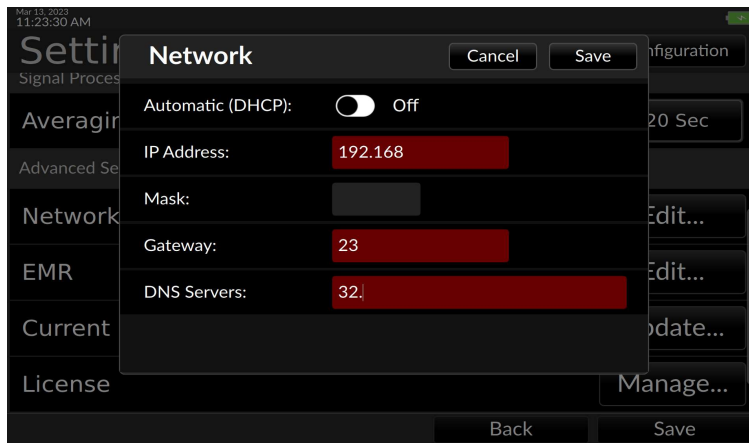

Fig. 7-19: Sample DHCP values filled in

Touch inside the entry fields to summon the virtual keyboard.

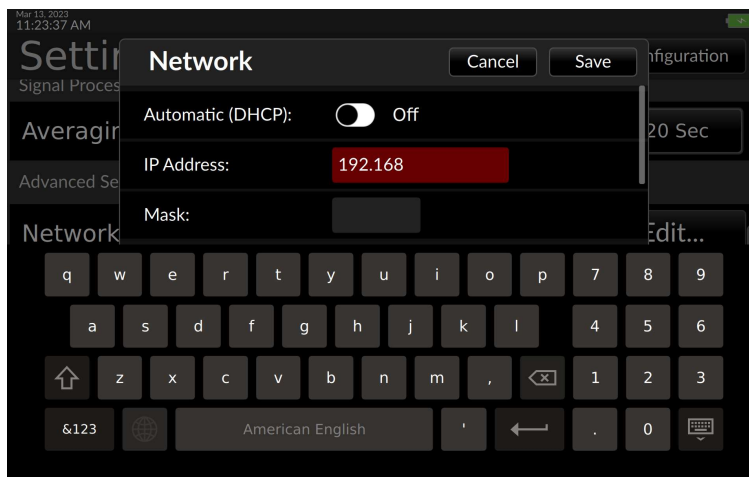

Fig. 7-20: Use the keyboard to enter network values

Configure the IP address, mask, gateway and DNS server as specified by the facility's IT department.

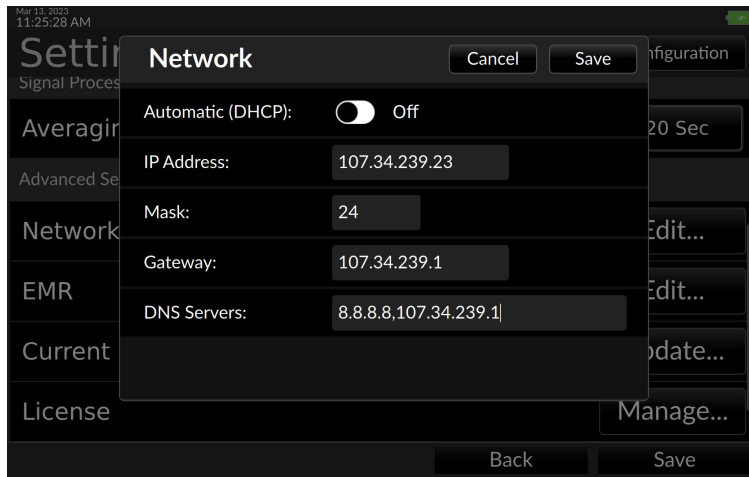

Fig. 7-21: Network settings

Close the dialog to return to the advanced settings page.

7.4 Configuring EMR servers

7.4.1 EMR Platform

The Argos can push data to a server for a particular patient based on the patient ID used by the EMR system. The Argos sends out HL7 data using the PCD-01 Transaction format: Device Observation Reporter → Device Observation Consumer. Alarm data for Argos alerts are sent in compliance with the PCD-04 Report Alarm transaction format: Alarm Reporter → Alarm Manager.

Current systems supported are:

- 1) Capsule
- 2) Masimo – legacy iSerona
- 3) Philips IntelliVue Connection

7.4.1.1 Patient Record Query

From a Patient Record Query server the Argos will attempt to receive the patient's age, gender, height, and weight. This ensures faster, less error-prone setup for the hemodynamic parameters the Argos requires to correctly calculate values and indices. The Argos monitor currently supports the following servers:

- 1) Corepoint

7.4.2 Adding EMR Server Entries

Proceed to the Advanced Settings screen (§7.1) and press “Edit” to the right of the EMR entry

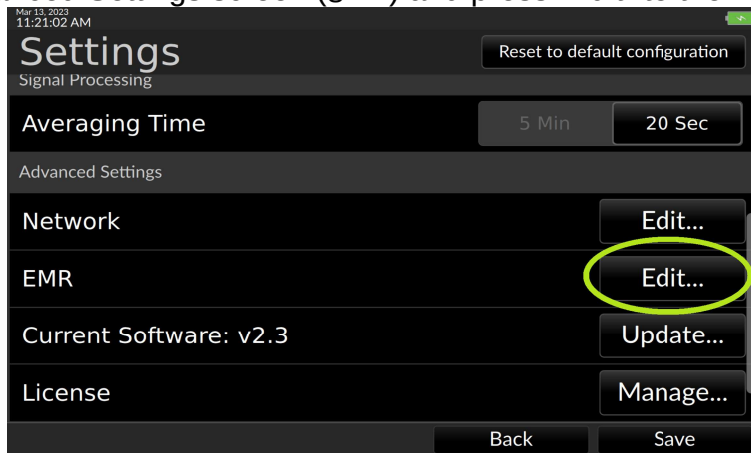

Fig. 7-22: Select EMR/Edit...

The EMR Settings screen appears

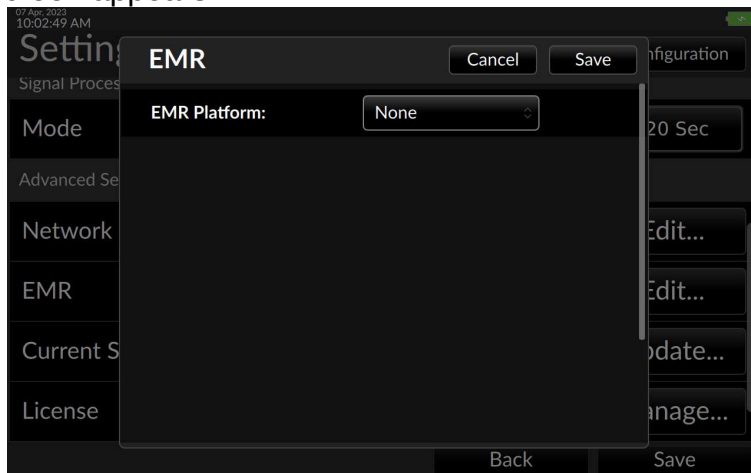

Fig. 7-23: The EMR Settings screen

Touching the box beside EMR Platform activates a drop down menu listing server choices. Select the facility's server: here, Capsule is selected.

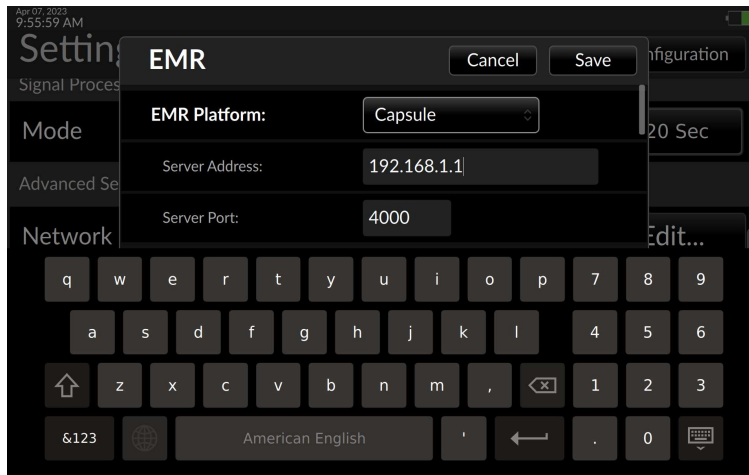

Fig. 7-24: Capsule server shown selected

Complete the server address and server port entries of the EMR platform. “Sending Facility” is an identifier for the monitor where the data is being captured: the user may want to put the hospital bed or room number where the monitor is located. “Receiving Facility” is where the Corepoint server is located: the facility’s name is one suggested value.

Proceed to the Patient Record Query server settings by pulling down the right-hand slider bar.

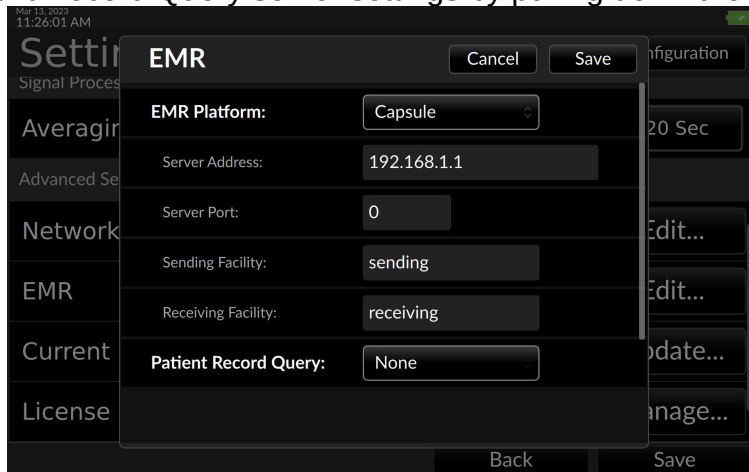

Fig. 7-25: Enter EMR server information

Fill in the Server Address, Server Port and Sending Facility and Receiving Facility for the server, in this case Corepoint.

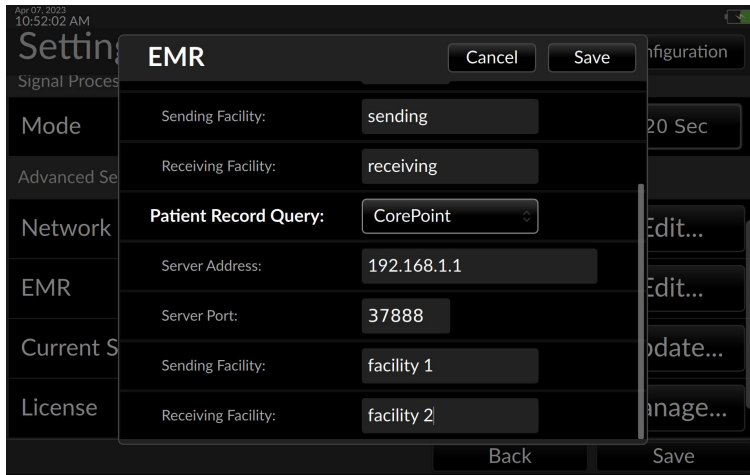

Fig. 7-26: Edit Patient Record Server details

- When Patient Record Query is configured to work with Capsule, the receiving facility must be set to “Capsule1” to enable receipt of data.

When the user has finished entering EMR parameters press “Save.” The Argos is now able to communicate with the facility’s EMR servers.

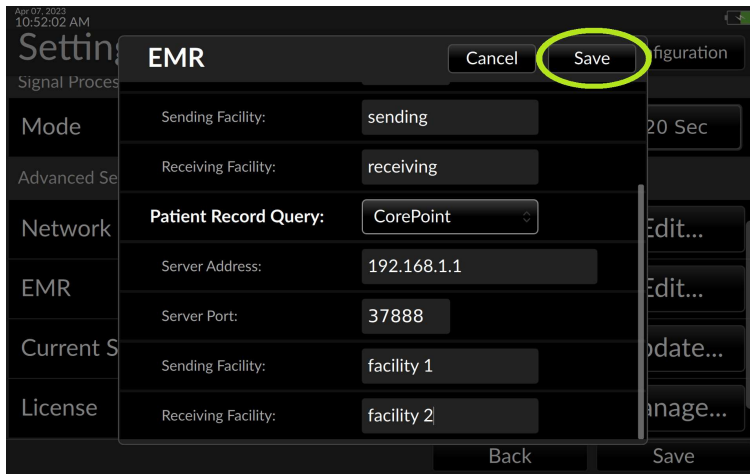

Fig. 7-27: Press Save to save and close EMR configuration

7.5 Updating the software

The software on the Argos monitor can be upgraded using a USB memory stick, coded to the device’s serial number. (Multiple monitors may only be upgraded with individual memory sticks.) A Retia sales representative can get the appropriate software upgrade if the monitors are covered under the maintenance plan.

**CAUTION**

Software upgrades may ONLY be performed by a qualified Retia trained individual.

To start the upgrade, place the memory stick in one of the USB slots on the side of the monitor. Go to the Settings menu and select Advanced Settings (§7.1). Touch the Update... button

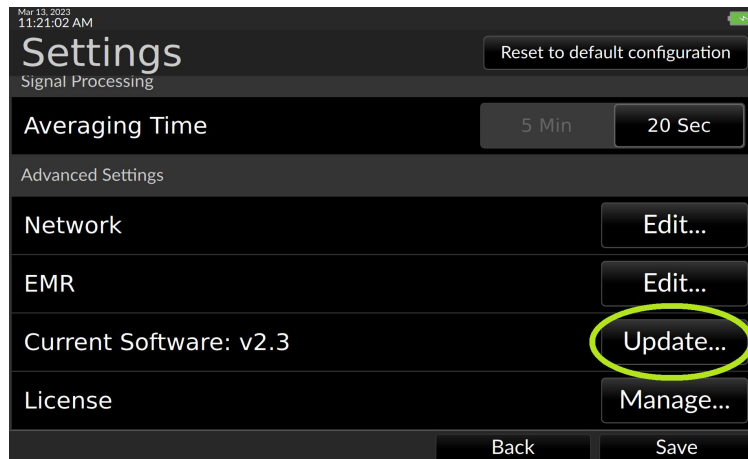

Fig. 7-28: Touch Update

The Argos will read the USB stick and, if a properly formatted USB drive containing the upgrade is found, prompt for confirmation. Select Install to continue.

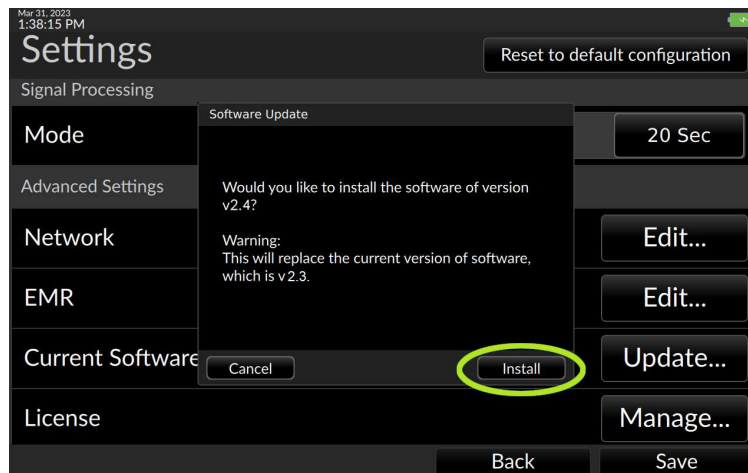

Fig. 7-29: Select Install to proceed with the software upgrade

The upgrade process begins. A bar displays the upgrade progress. When the upgrade is completed, the user is prompted to remove the USB drive.

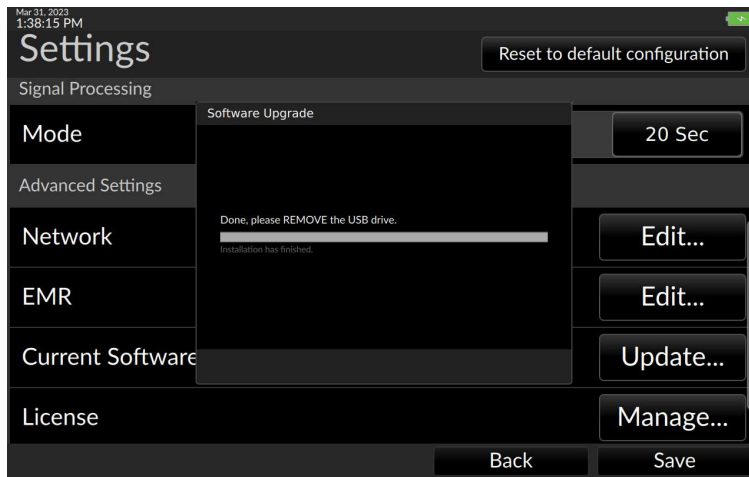

Fig. 7-30: Update complete, please remove the USB stick

The monitor needs to be rebooted to complete the upgrade. Once the drive has been removed, a screen prompts the user to shut down. Press Shutdown to power off the monitor.

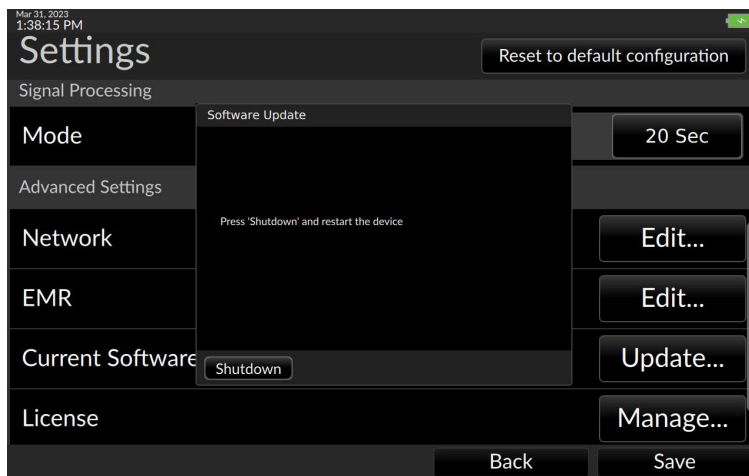

Fig. 7-31: Press Shutdown to reboot the device

The monitor will power off. Wait for the power indicator to turn off, then press and hold the power button for five seconds following shutdown to restart the monitor with the new software installed.

Upon reboot, to verify the upgrade, press the User Menu icon and select About:

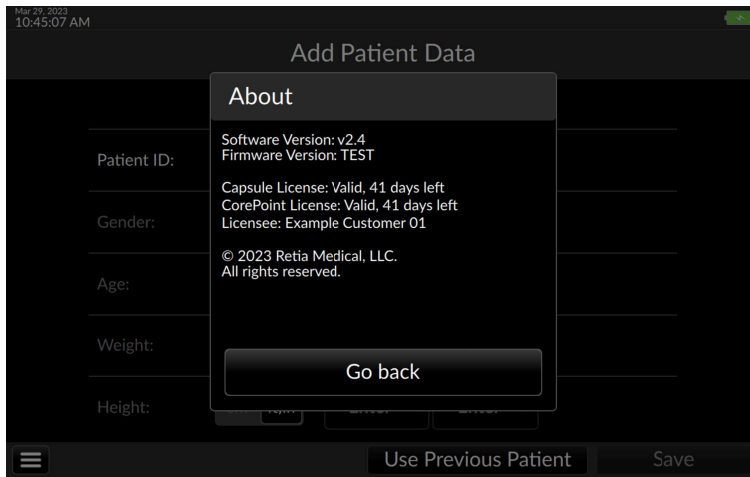

Fig. 7-32: About page showing the upgraded version

If when an upgrade is attempted and there is no USB stick in the slot, more than one USB drive is inserted, or the drive does not contain the upgrade, an error message appears.

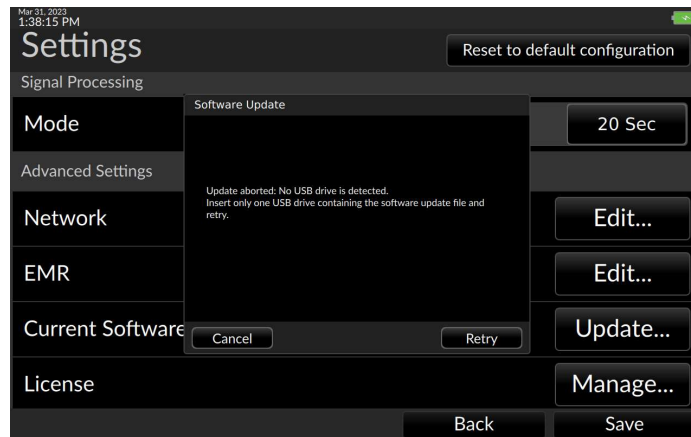

Fig. 7-33: No USB drive detected

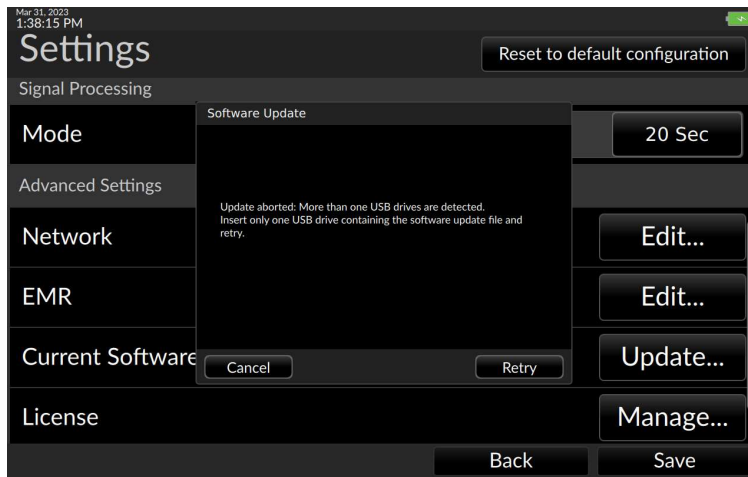

Fig. 7-34: More than one USB drive detected

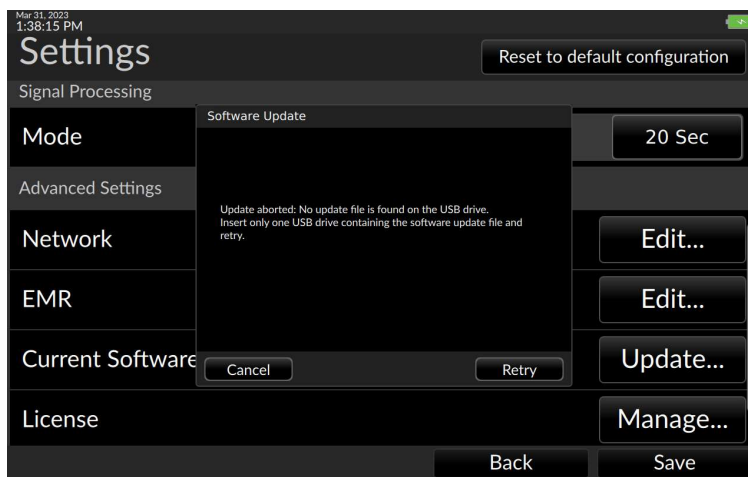

Fig. 7-35: No update file found

Correct the error and retry the upgrade.

8 Help

The following is a list of error messages and recommended actions:

Message	Possible cause(s)	Suggested action
Check Arterial BP waveform	<p>Arterial BP waveform signal quality is insufficient to calculate CO</p> <p>Noisy BP signal due to patient/cable movement</p> <p>Electromagnetic interference from high frequency electrosurgical equipment or other sources</p> <p>Very low pulse pressure, Systolic Pressure too high or Diastolic pressure too low</p> <p>Non-physiological BP signal due to occluded/disconnected transducer tubing</p>	<p>Check the arterial BP waveform for sources of noise, from patient to the Argos monitor</p> <p>Check the arterial waveform for physiological causes of artifact such as severe hypotension, severe hypertension, or motion artifact.</p> <p>Inspect all arterial pressure lines. Ensure stopcocks are properly positioned.</p> <p>Inspect the arterial catheter. Ensure it is not blocked or kinked.</p> <p>Make sure the transducer is aligned with the patient's phlebostatic axis.</p> <p>Re-zero the transducer.</p>
Check cable connection	<p>Transducer cable is disconnected</p> <p>External monitor cable is disconnected</p>	<p>Check cable connection to the transducer</p> <p>Check cable to the external monitor</p>
Low Battery	Argos Monitor is operating on internal battery power and the battery level is below 25%	Plug in the Argos monitor to the AC mains. If the battery no longer holds a charge after connecting to a working mains, it needs to be replaced. Contact Retia Medical Technical Support.
Internal Error	Internal System malfunction	Power off system and restart the monitor. If problems persists, contact Retia Medical Technical Support.
Verification failed	<p>Cannot connect to server</p> <p>Server communication error</p> <p>No record found</p> <p>More than one record found</p>	<p>Verify Patient ID</p> <p>Verify device network settings</p> <p>Verify network is up</p> <p>Correct server Patient ID</p>

Table 7: Troubleshooting error messages

Notes:

1. If the software freezes and the device becomes unresponsive, press the power button for at least 30 seconds to initiate a forced shutdown.

2. Because the Argos monitor is not used as a stand-alone patient monitor, all alerts, including CO and derived hemodynamic monitoring parameters, are low priority.



WARNING

A hazard can exist if different alarm/alert presets are used for the same or similar equipment in any single area.

3. When a monitored parameter exceeds an upper or lower alert limit, a yellow box will highlight the displayed limit. Please see section 5.1, page 46 for more details.
4. Alerts are fully visible to a user operating the Argos monitor facing the screen.
5. If the Argos monitor detects artifacts or noise in the BP signal for any reason, in addition to displaying an error message on the status section of the status bar as listed above, the monitor will not display numeric trend values:

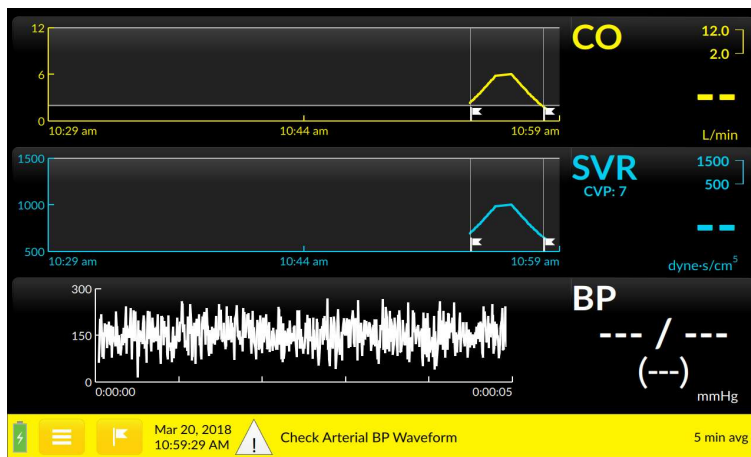

Fig. 8-1: Error message displayed, with null trend values

- *After correction of the condition which led to the error, while the error message may disappear, allow at least 25 seconds for the sample size to produce accurate results.*

If any of the indicated solutions does not work, or the user is experiencing any other problems or issues with the Argos monitor, contact Retia Medical technical support by phone at (+1) 914 437 6704 or email at info@retiamedical.com.

8.1 Specifications

The Argos Cardiac Output Monitor measures cardiac output (CO) and derived hemodynamic parameters when used with an appropriate radial or femoral artery sensing device.

Appendix A includes summaries of the following:

- Physical and Mechanical Specifications
- Electrical Specifications

- Environmental Specifications:
 - Operating Conditions
 - Transport and Storage Conditions
- Displayed Parameters
- Standards Compliance
- Monitor and Accessories part numbers

Table 8: Physical and Mechanical Specifications

Attribute	Value	
Weight	8.3 lb. / 3.76 kg	
Dimensions	Height	10.6" / 269.5 mm
	Width	12.36"/ 314 mm
	Depth	3.86" / 98 mm
Display	Type	10.1" Color TFT LCD, touch screen
	Viewing area	8.54" x 5.34"/ 216.96mm x 135.6mm
	Resolution	1280 x 800
User interface	Touch screen	
Data Capacity	1200 hours	
Data Export	FAT32-formatted, USB 2.0-compatible, removable drive.	

Table 9: Electrical Specifications

Attribute	Value
Mains Voltage	100 to 240 V, AC
Mains Frequency	50/60 Hz
Power Consumption	36 W
Bedside patient monitor input	1 V/100 mmHg

Table 10: Environmental Specifications

Property	Value
Operating conditions	
Temperature range	5 to 35 °C
Relative Humidity	10 to 95 %
Ambient Pressure	70 to 106 kPa
Transport and Storage Conditions	
Temperature range	-25 to 70 °C
Relative Humidity	10 to 100 %
Ambient Pressure	50 to 106 kPa

Table 11: Parameters

Parameter	Specification	
CO	Reproducibility	0.1 l/minute
	Update Rate	5 seconds

Table 12: Standards Compliance

Applied Part Type	1x Type CF defibrillation-proof
Equipment class	Class II
Electrical Protection Class	IEC Class I
Ingress Protection Class	IPX1
IEC Standards	IEC 60601-1:2005+AMD1:2012
	IEC 60601-1-2:2014
	IEC 60601-2-34:2011*
	IEC 60601-1-8: 2011
	IEC 62366-1:2015
Packaging standard	ISTA 2A

*Not including the section (208.6) on alarms. All alarms are governed by IEC 60601-1-8.

Table 13 Argos Cardiac Output Monitor and Accessory Part Numbers

Item/Category	Part number
Argos Cardiac Output monitor	FG-001
Bedside patient monitor interface cables	
Interface cable for Philips Monitors	FG-002
Interface cable for GE PDM Monitors	FG-003
Interface cable for GE Solar Monitors (with TRAM RAC 4A)	FG-005
Interface cable for Draeger Monitors	FG-006
Interface cable for Spacelabs Xprezzon Monitors	FG-007
Interface cable for Mindray BeneVision N series Monitors	FG-011
Interface cable for Nihon Kohden Monitors	FG-012
Parts and Accessories	
LAN Connectivity Kit	FG-008
Serial Connectivity Kit	FG-009
Replacement Power Supply and AC cord	FG-010
Utah Medical BP Transducer Kit (pack of 25): includes BP Transducer, Y connector, tubing	902-649
Utah Medical Transducer Interface Cable	650-299-117
Custom adjustable pole mount roll stand	IMS-003BR2
Table/pedestal stand	30-036
Adjustable Rail Clamps	FLP-0008-17
Operator's Manual	60-001
Quick Start Guide	60-025
Retia Service Manual	60-026

To order parts or accessories please contact Retia customer support or your Retia representative.



WARNING

The Argos monitor should not be used to monitor arterial blood pressure. The arterial blood pressure transducer input on the Argos monitor is to be used only when another arterial blood pressure transducer is connected in parallel to a bedside patient monitor with the appropriate blood pressure alarms.



WARNING

Before connecting a bedside patient monitor to the Argos monitor, consult with the Retia Medical representative to ensure the bedside patient monitor has the correct specifications.



WARNING

Only connect accessories that have been qualified as part of the Argos monitor.

8.2 Equations for Calculated Patient Parameters

Table 14: Hemodynamic Parameters			
Parameter		Formula	Units
Cardiac Output	CO	Proprietary MBA algorithm	L/min
Cardiac Index	CI	Cardiac Index $CI = CO/BSA$ where: CI - Cardiac Index, CO - Cardiac Output, L/min BSA - Body Surface Area, m ²	L/min/m ²
Mean Arterial Pressure	MAP	Average systemic arterial blood pressure.	mmHg
Heart rate	HR	Number of heartbeats per minute.	Bpm (beats/min)
Blood pressure	BP	The pressure of blood in the circulatory system.	mmHg
Stroke Volume	SV	Stroke Volume $SV = (CO/HR) \times 1000$ where: CO - Cardiac Output, L/min HR - Heart rate, beats/min	mL
Stroke Volume Index	SVI	Stroke Volume Index $SVI = (CI/HR) \times 1000$ where CI - Cardiac Index, L/min/m ² HR - Heart rate, beats/min	mL/m ²

Table 14: Hemodynamic Parameters			
Parameter		Formula	Units
Systemic Vascular Resistance	SVR	Systemic Vascular Resistance $SVR = \{(MAP - CVP) \times 80\} / CO$ (dyne-sec/cm ⁵) where: MAP - Mean Arterial Pressure, mmHg CVP - Central Venous Pressure, mmHg CO - Cardiac Output, L/min	dyne-s/cm ⁵
Systemic Vascular Resistance Index	SVRI	Systemic Vascular Resistance Index $SVRI = \{(MAP - CVP) \times 80\} / CI$ where: MAP - Mean Arterial Pressure, mmHg CVP - Central Venous Pressure, mmHg CI - Cardiac Index, L/min/m ²	dyne-s-m ² /cm ⁵
Pulse Pressure Variation	PPV	The difference between maximum and minimum pulse pressure over a respiratory cycle, per mean pulse pressure	%

Table 15: Technical Details for Dynamic Assessment	
Filtering equation	The dynamic assessment module filters all incoming data through a 3 sample median filter. One invalid input sample makes the result of the filter invalid. $median(x_i, x_{i-1}, x_{i-2})$
Instability equation	A baseline is considered unstable if its Coefficient of Variation is greater than or equal to 5%. $CV = \frac{s}{\bar{x}}$
Percent Change	If b is the value of the baseline, percent change is calculated as follows: $\frac{x_i - b}{b} \cdot 100\%$
Challenge Validity	A challenge is considered valid if there is one filtered sample above 10% or if greater than two thirds of the samples in the challenge are valid.

For further information please visit www.retiamedical.com, or contact us by email or phone.

8.3 Default Settings

Table 16: Argos Monitor Defaults

Parameter	Min Graph Default	Max Graph Default	Graph Setting increment	Low Alarm Default	High Alarm Default	Alarm Setting Increment	Color
CO	2	10	1	4	8	0.1	Yellow
CI	1	5	1	2.5	4	0.1	Yellow
SV	20	120	20	60	100	5	Light Blue
SVI	10	60	20	30	50	5	Light Blue
SVR	500	2000	100	800	1200	50	Purple
SVRI	1000	4000	200	2000	2400	50	Purple
MAP	50	120	20	65	100	5	Red
HR	40	140	20	60	100	5	Green
PPV	0	20	10	0	13	1	Gray
BP	50	150	10	NA	NA	NA	Red

- For SVR and SVRI, default CVP is 7 mmHg
- Monitoring Mode Default: 20 seconds
- Date Format Default: MM/DD/YY
- Time Format: 12-hour Time (HH: MM AM/PM)
- “Show SVI” and other indexed parameters are selected
- Time Scale Default: 10 minutes
- Default event flag for “Start Session”
- Default parameters on Trend Screen: Stroke Volume (SV), Systemic Vascular Resistance (SVR), and Blood Pressure (BP)

8.4 Unit Conversions

8.4.1 lbs to/from kg

Conversion factors: lb → kg: lb ÷ 2.2
 kg → lb: kg x 2.2

8.4.2 inches to/from cm

Conversion factors: inches → cm: inches x 2.54
 cm → inches: cm ÷ 2.54

8.5 Care, Service, and Support

Only clean the Argos monitor as directed in this appendix.

No other scheduled maintenance or routine service is required: the Argos monitor contains no user-serviceable parts, and should only be repaired by a service representative authorized by Retia.

Information on contacting a Retia Medical representative for support, repair, or replacement may be found at the end of this appendix.

The expected service life of the Argos Monitor is 5 (five) years.



WARNING

The Argos monitor contains no user-serviceable parts. Removing the cover or any other disassembly will expose the user to hazardous voltages.



WARNING

Shock or fire hazard! Do not immerse the Argos monitor or cables in any liquid solution. Do not allow any fluids to enter the device.

8.6 Cleaning the Monitor



CAUTION

Do not pour or spray liquid onto the monitor or accessories.

To clean the surface of the Argos Monitor, dampen a clean cloth with disinfectant, either

- 70% isopropyl alcohol solution
- diluted bleach solution (1 part bleach to 10 parts water)
- a non-abrasive liquid commercial cleaner

Lightly wipe the surface of the Argos monitor.

8.7 Monitor Maintenance

Periodically inspect the monitor for signs of wear. Check to make sure the monitor body is intact and not broken or cracked, and shows no sign of abuse or tampering.

8.8 Cable Maintenance



CAUTION

Do not immerse cable connectors in detergent, isopropyl alcohol or glutaraldehyde.



CAUTION

NEVER:

- Allow any liquid to come in contact with the power cable.
- Allow any liquid to penetrate connectors or openings in the case

Should liquid contact the power cable or penetrate the case, do not attempt to operate the monitor. Instead, shut down the monitor, disconnect power immediately, and call the Biomedical Department or Retia Medical representative.



CAUTION

Do not use any heating device to dry cable connectors.



CAUTION

Regularly inspect all cables for defects. Never coil cables tightly while using, or when storing.



CAUTION

If any electrolytic solution such as NaCl, Lactated Ringers, is allowed to contact the cable connectors while connected to the Argos monitor, and the monitor is turned on, the excitation voltage may cause electrolytic corrosion and rapid degradation of the electrical contacts. Therefore, do not allow electrolytic solutions to contact the cable connectors.

Periodically inspect cables and lines for signs of wear or age. Discontinue use immediately if the user finds fraying cable, cracked or broken insulation, or faulty (broken pins, cracking housing) connectors, or exposed electrical or mechanical contacts.

From time to time, or as needed, wipe the patient cable with a clean cloth using 10% bleach and 90% water. Allow the cable to air dry.

8.9 Data Port Maintenance

The port on the side of monitor is meant for data export only and is locked for any other purpose. The Argos monitor does not have any capability for network connection. Do not use USB drives containing any executable.

If the user needs further assistance, please contact Retia Medical.

8.10 Expected Service Life

The expected service life of the Argos Cardiac Output Monitor is 5 (five) years. However care should be taken to ensure its continuing operability: therefore, periodically inspect the device to ensure it is fully functional. Discontinue use immediately if:

- Cables are frayed
- Screen and/or enclosure cracked or show signs of functional wear
- Labels torn or tampered with
- Battery incapable of holding a charge for 30 minutes
- Connectors loose or broken
- Monitor shows evidence of overheating

8.11 Service and Support

See **§8 Help** for diagnosis and remedies. If the user still cannot solve the problem, please contact Retia Medical by phone at (+1) 914 437 6704 or email at info@retiamedical.com

When calling, please have at hand:

- The monitor's serial number, printed on the rear panel;
- The text of the error message(s), if any, and detailed information as to the nature of the problem.

8.12 Alert Functionality Verification

To confirm alert capability, follow this procedure:

1. Note the current value for SV.
2. Press the SV trend label to change the upper alert limit, as described in §5.8.5, page 73, to a value lower than the current SV value, and press Save.
3. Verify that in the SV numeric area, the upper alert limit is highlighted with a yellow box.
4. Press the SV trend label to change the lower alert limit to a value higher than the current SV value, and press Save.
5. Verify that in the SV numeric area, the upper alert limit is highlighted with a yellow box.
6. Adjust the alert limits for future patient monitoring.
7. Disconnect the external monitor cable.
8. Verify that the status bar turns yellow and displays the message "Check cable connection".
9. Connect the external monitor cable back into the Argos monitor.



WARNING

Ensure that after alert verification, the alert limits are adjusted to physiologically appropriate values for patient monitoring.

9 Clinical Studies

9.1 Chapter Overview

This chapter provides information on the clinical validation study using the Argos Hemodynamic Monitor. A Reference Bibliography containing additional clinical studies is available on Retia's website (www.retiamedical.com) or by contacting a Retia Medical Customer Service representative.

An adult study was performed on critically ill patients in the operating room and intensive care unit comparing the accuracy of the cardiac output (CO) measurements from the Argos Monitor to the accuracy of CO measurements from the predicate device (Edwards Lifesciences' Vigileo Cardiac Output Monitor version 3). The accuracy of both devices was determined with respect to reference cardiac output readings obtained via the thermodilution method, from a pulmonary artery (PA) catheter. The study was performed on 40 patients under informed consent as part of a protocol approved by the IRB for Columbia University Medical Center (Predicate Comparison Study). No adverse events attributable to the Argos Monitor were reported during the study.

The Predicate Comparison Study evaluated the accuracy of the CO values as reported by the Argos Monitor compared to the reference CO values obtained via a pulmonary artery catheter. For the reference CO, both bolus thermodilution and continuous PA catheter measurements were used. Accuracy of the predicate device CO measurements was evaluated similarly, with respect to the same CO reference. Finally, the absolute and trend accuracy of the Argos monitor was compared with the predicate device. Both the Argos and predicate device calculated CO via analysis of the same blood pressure waveform from a radial or femoral arterial catheter.

The 40 patients included: 20 operating room (OR) patients (liver transplant and cardiac surgeries) and 20 intensive care unit (ICU) patients (post-liver transplant and post-cardiac surgery); 28 males and 12 females; age 20 to 83 years, with a mean of 62 years. Out of a total of 236 possible data points, 32 were removed due to missing signal (BP or reference CO) and 15 were removed due to signal artifact or hemodynamic instability in accordance with the data selection criteria, leaving 189 time points available for analysis.

Methods: Reference cardiac output measurements from the PA catheter (including the reference time points) were recorded along with Blood pressure signals, which were simultaneously fed to the Argos and the predicate monitors. For the OR patients, reference measurements were made according to pre-defined surgical landmarks. In the case of liver transplants, these were: incision, pre-clamping of the vena cava, post-clamping, post-unclamping, and closure. In the case of cardiac surgeries, these were: incision, pre-bypass, post-bypass, and closure. In the case of ICU patients, the time points were every 2 hours when reference measurements were available.

9.1.1 Results:

$y = 0.87x + 0.71$
Pearson's $r = 0.63$
Percentage within error grid
(dotted lines) = 54.5%

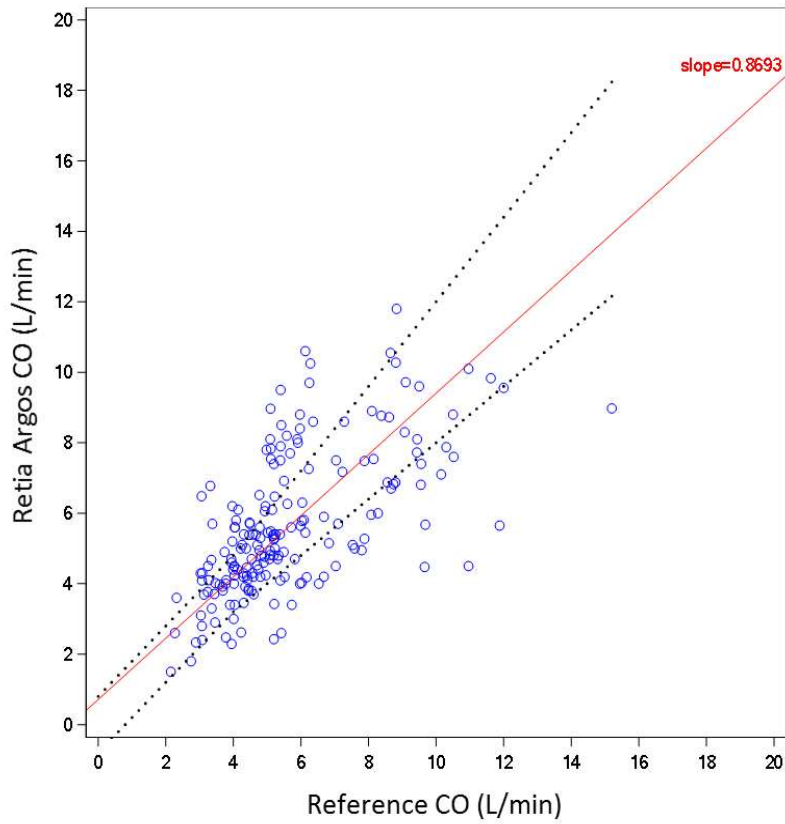

Fig. 9-1: Regression (unweighted Deming) plot for Retia Argos CO versus reference CO for all patients

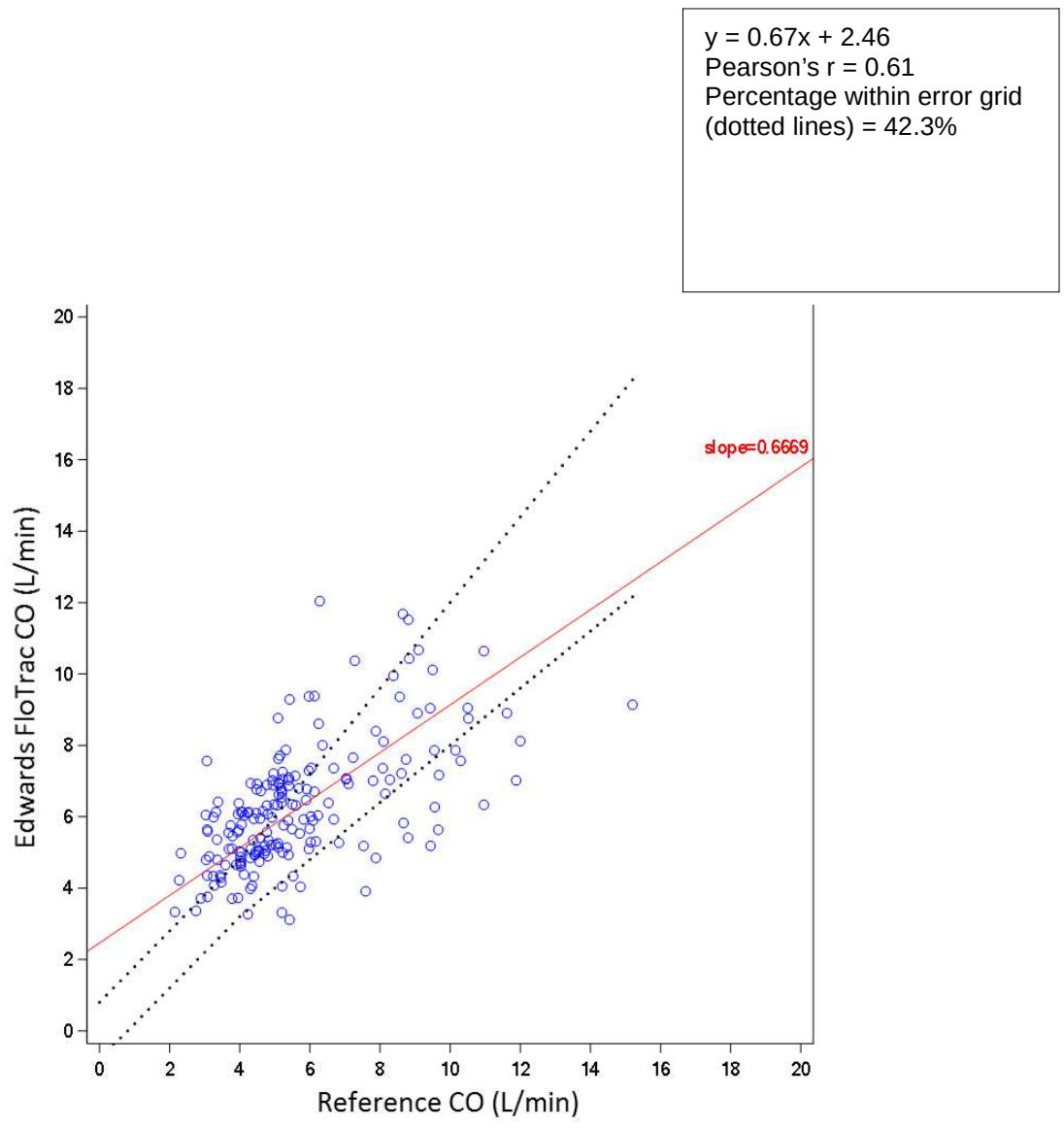

Fig. 9-2: Regression (unweighted Deming) plot for predicate CO versus reference CO for all patients

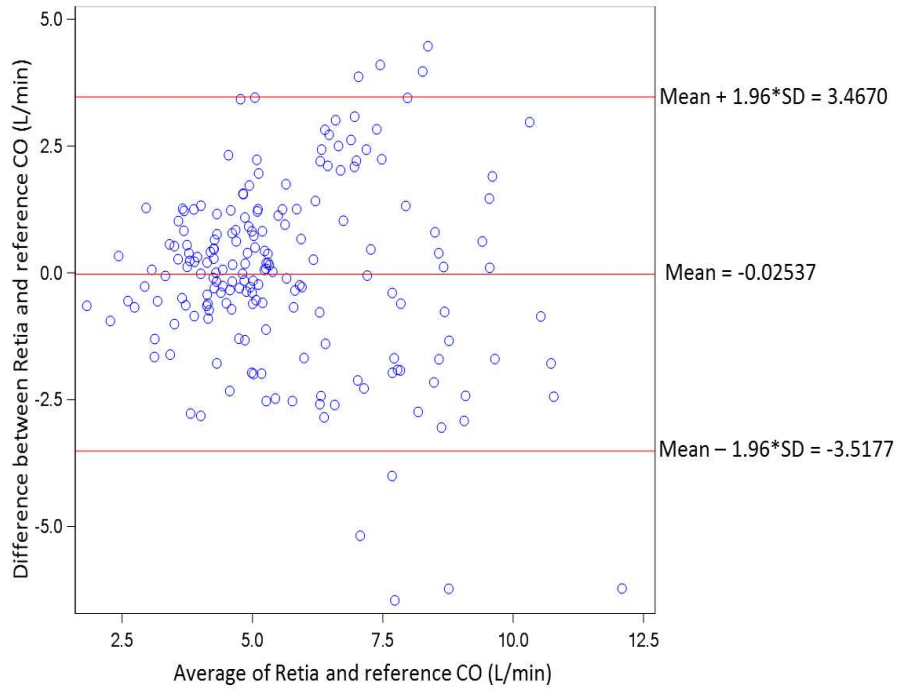

Fig. 9-3: Bland-Altman plot comparing Retia Argos CO to reference CO for all patients. LOA [-3.52 to 3.47]

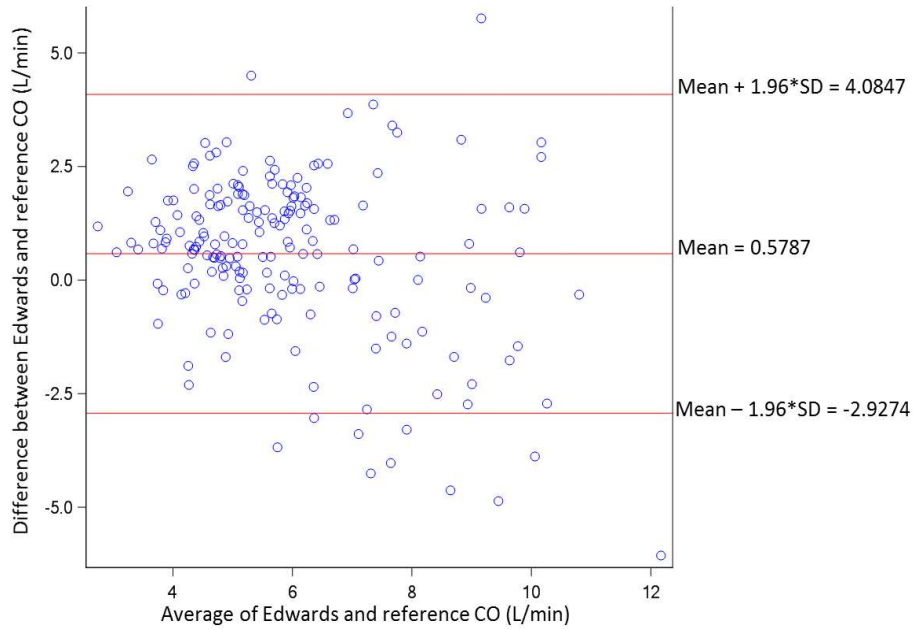

Fig. 9-4: Bland-Altman plot comparing predicate CO to reference CO for all patients. LOA [-2.93 to 4.08]

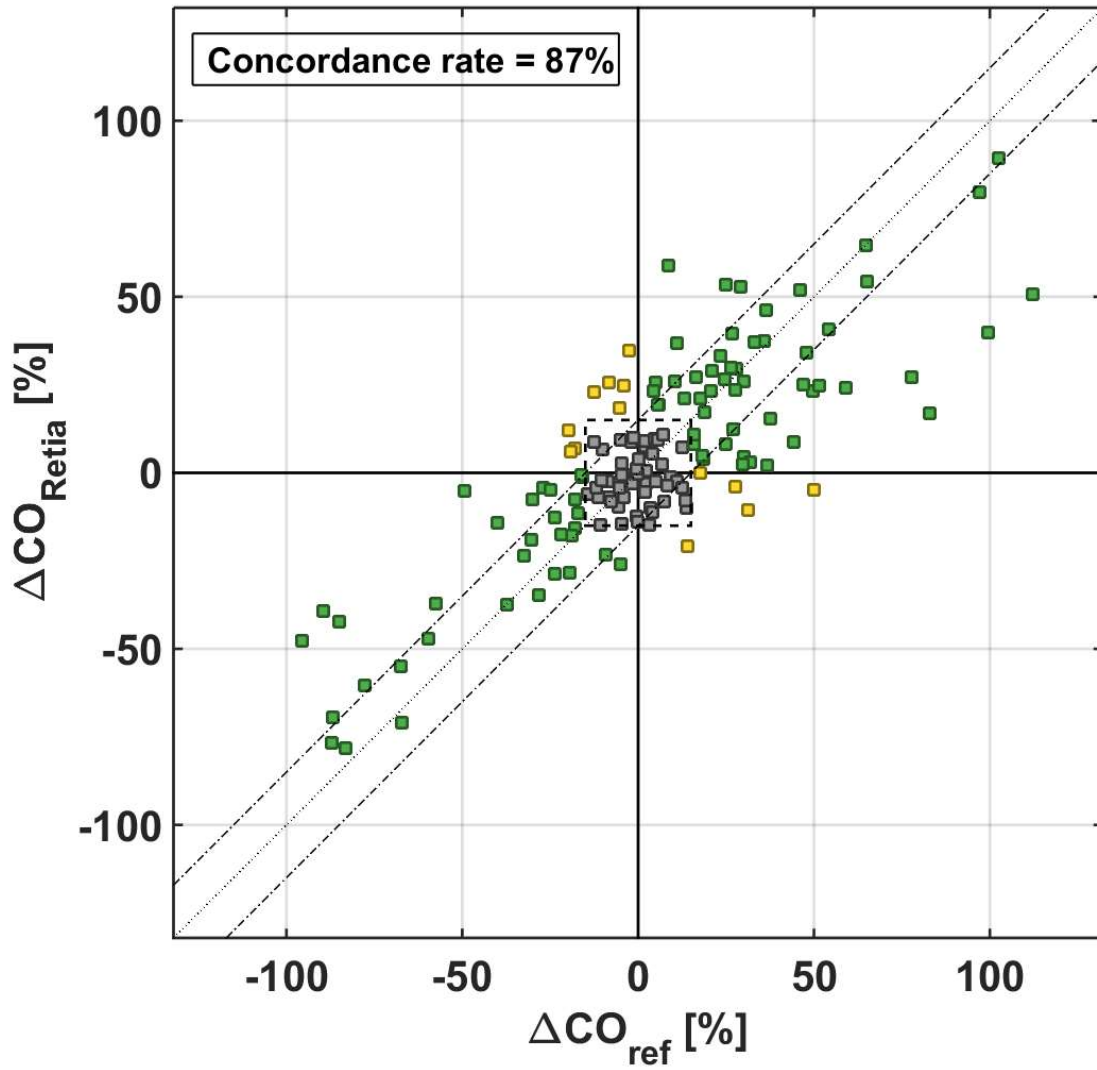

Fig. 9-5: Concordance plot for percentage changes in Retia Argos CO versus percentage changes in reference CO

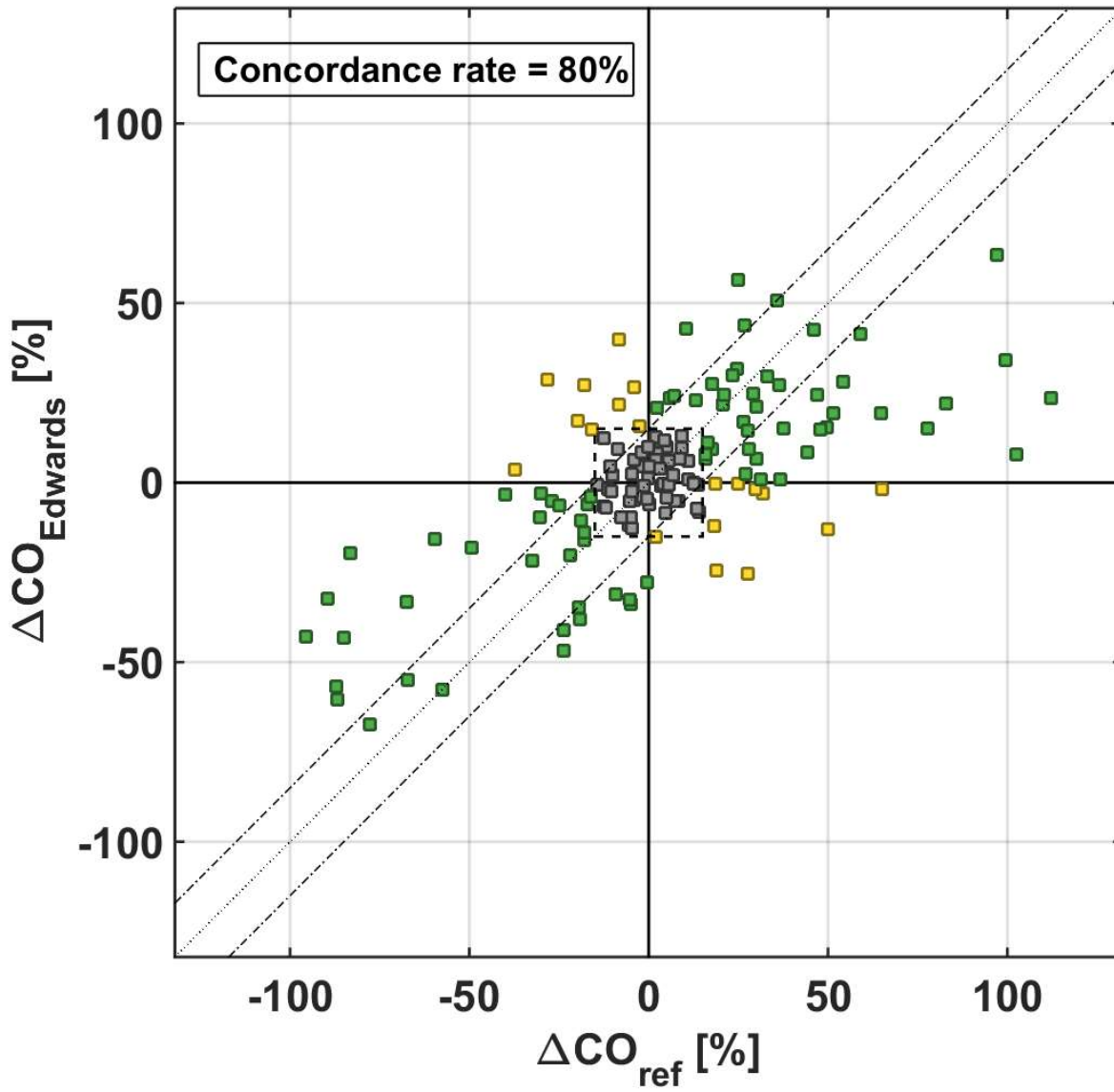

Fig. 9-6: Concordance plot for percentage changes in predicate CO versus percentage changes in reference CO

Analysis subgroup	Performance metric with respect to CO-Thermodilution	Retia-Argos [95% CI]	Predicate device [95% CI]
Overall CO	Bias	-0.03 L/min [-0.53 to 0.47]	0.58 L/min [-0.12 to 1.04]
	Precision	1.78 L/min [1.52 to 2.15]	1.79 L/min [1.56 to 2.10]
	NRMSE	31.5%	33.2%
	Concordance Rate	87% [81.3 to 91.9]	80% [74.2 to 86.2]
CO ≥ 5 L/min	RMSE	2.09 L/min	2.05 L/min
CO < 5 L/min	RMSE	1.19 L/min	1.62 L/min

Table 17: Summary statistics including bias, precision, normalized root mean squared error (NRMSE), concordance and root mean squared error for sub-group analyses.

The NRMSE represents the average size of error in percentage of a device. Specifically defined as follows:

$$NRMSE = 100 \cdot \frac{\sqrt{\mu^2 + \sigma^2}}{E(X)}$$

where μ is the bias, σ is the precision, and $E(X)$ is the expected value (or average) of the reference CO.

The RMSE is computed as follows:

$$RMSE = 100 \cdot \sqrt{\mu^2 + \sigma^2}$$

Concordance was calculated using a 15% exclusion zone as recommended in Critchley, L. A., Lee, A. & Ho, A. M. H. A critical review of the ability of continuous cardiac output monitors to measure trends in cardiac output. *Anesth. Ana.* 111, 1180–1192 (2010).

Percentage within the error grid was calculated according to Forrest, S.W. et al. Statistical Comparison of Cardiac Output Measurement Methods: Advantages of an Error Grid Representation. *Journal of Cardiac Failure*, Volume 14, Issue 6, S56.

Validation with femoral BP

To validate the Argos monitor's performance when using femoral BP signal as the input, a study similar to the one described above was performed. The purpose of the study was to

evaluate the accuracy of the Argos monitor and Edwards Lifesciences' Vigileo Cardiac Output Monitor version 3, with the reference CO measured via the continuous thermodilution method, from a pulmonary artery catheter (PAC). The study was performed with data from 22 adult patients undergoing liver transplant surgery, collected under informed consent as part of a protocol approved by the IRB for Columbia University Medical Center.

Analysis methods follow the Predicate Comparison study above. CO estimates from the Argos and the Edwards devices were obtained by simultaneously feeding the femoral BP waveforms to both devices. These estimates were then compared to the reference CO at the following surgical landmarks: incision; pre-clamping of the vena cava; post-clamp; post-unclamp; and closure.

The 22 patients included 13 Males and 9 females; age 19 – 69 years (mean age 54 years). In one of the subjects, 2 measurements were excluded due to instability of the reference CO, in accordance with the data selection criteria, leaving a total of 108 measurements available for analysis. For the concordance analysis, percent change between consecutive segments was used for each method (reference, Argos and Edwards Vigileo). A total of 86 changes were available for the concordance analysis. Figures 9-7 through 9-11 show the Regression, Bland-Altman, and Concordance plots for the Argos and the Vigileo device, with thermodilution as the reference.

Results are shown in Table 18 below.

Analysis subgroup	Performance metric with respect to CO-Thermodilution	Retia-Argos [95% CI]	Predicate device [95% CI]
Overall CO	Bias	0.75 L/min [-0.09 to 1.58]	0.23 L/min [-0.60 to 1.06]
	Precision	2.13 L/min [1.73 to 2.78]	2.30 L/min [1.89 to 2.93]
	NRMSE	33.7%	34.4%
	Concordance Rate	94%	87%
CO < 5 L/min	Bias	0.98 L/min [0.43 to 1.52]	1.53 L/min [0.84 to 2.22]
	Precision	1.15 L/min [0.91 to 1.59]	1.46 L/min [1.14 to 2.03]
	NRMSE	38.3%	34.4%
CO ≥ 5 L/min	Bias	0.67 L/min [-0.26 to 1.59]	-0.25 L/min [-1.11 to 0.62]
	Precision	2.31 L/min [1.87 to 3.03]	2.29 L/min [1.88 to 2.92]
	NRMSE	31.1%	29.8%

Table 18: Summary statistics including bias, precision, NRMSE and concordance for all data and subgroups. Note that concordance is not calculated for the subgroups due to restricted data.

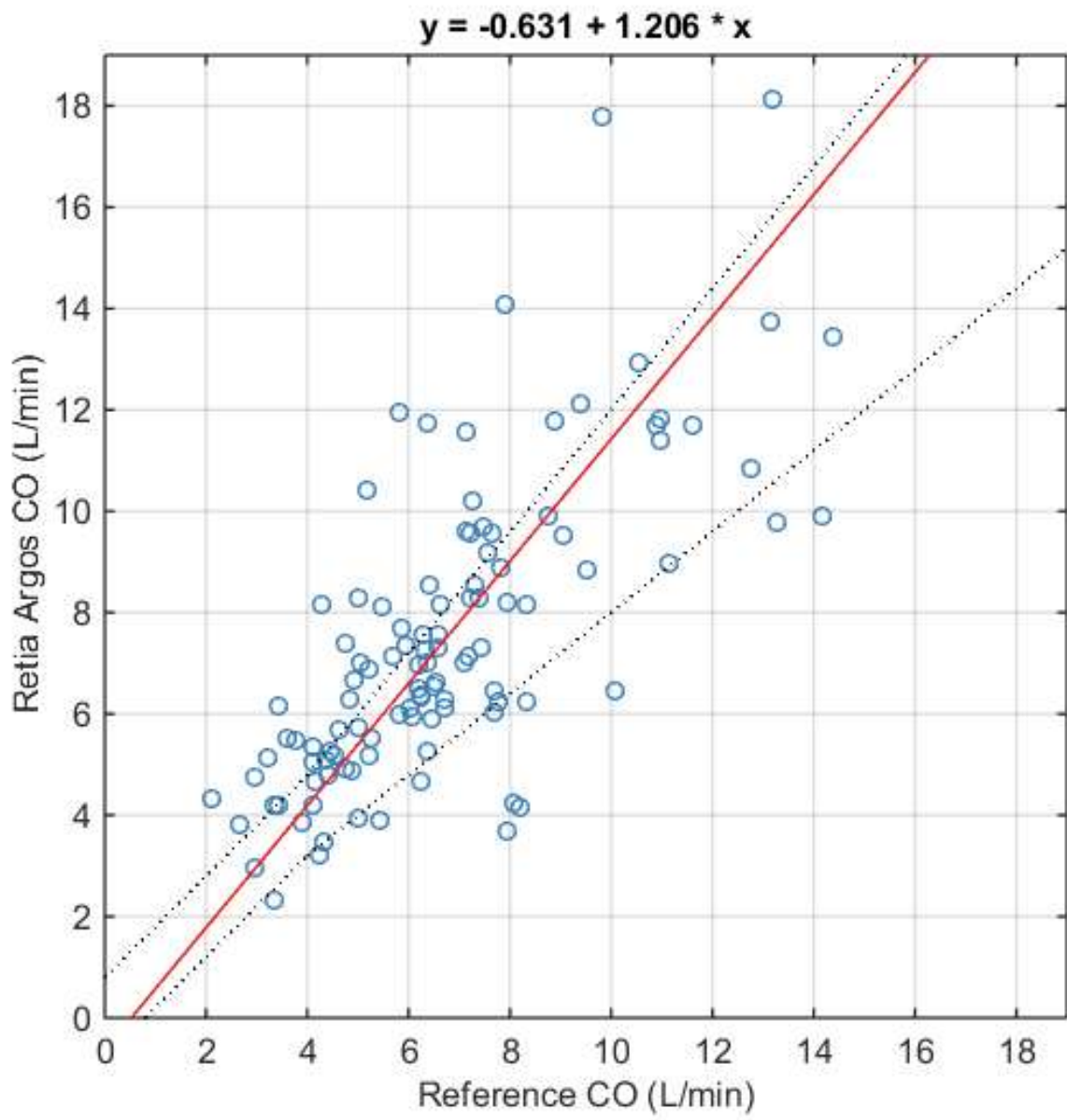

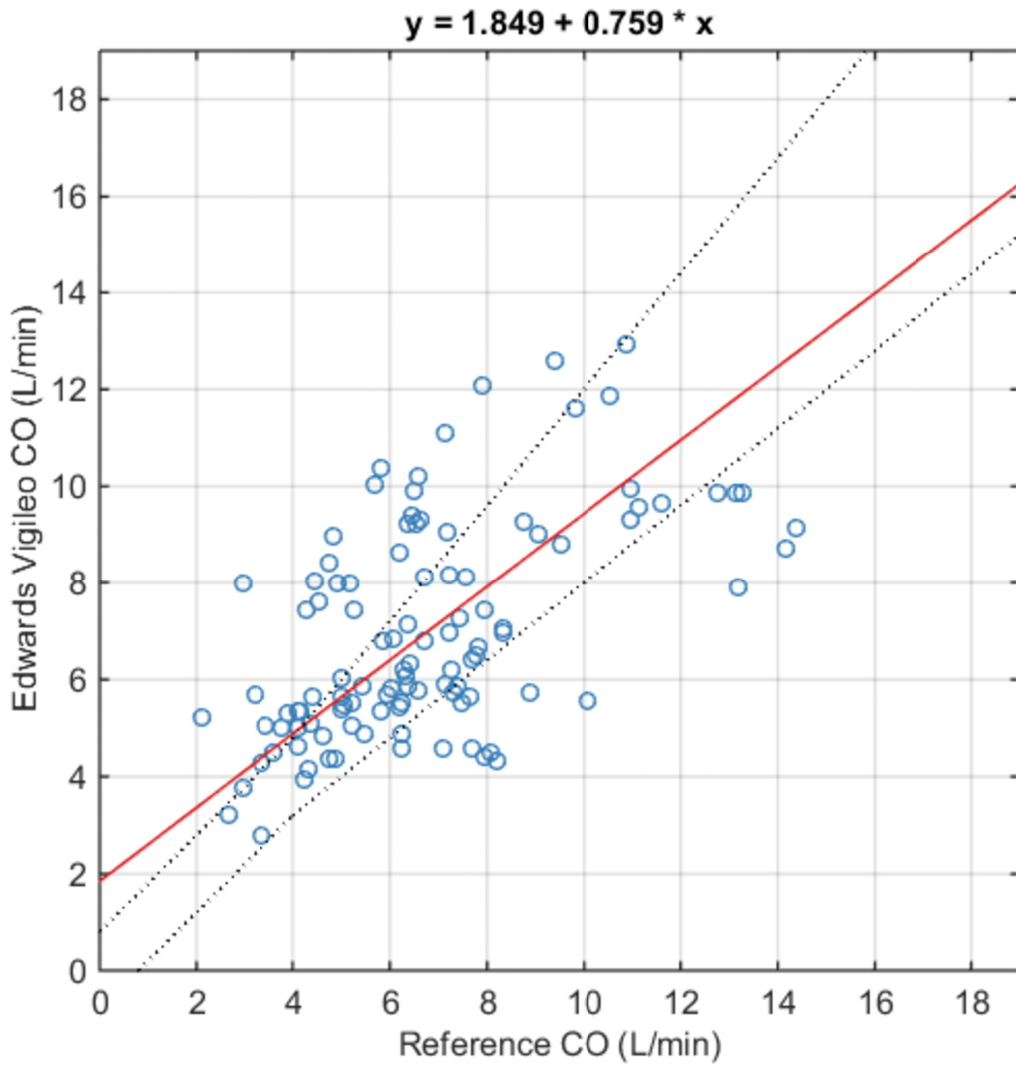

Fig. 9-7: Regression (unweighted Deming) plots for Vigileo CO versus reference CO. Pearson's $r = 0.57$; Percentage within error grid = 49%

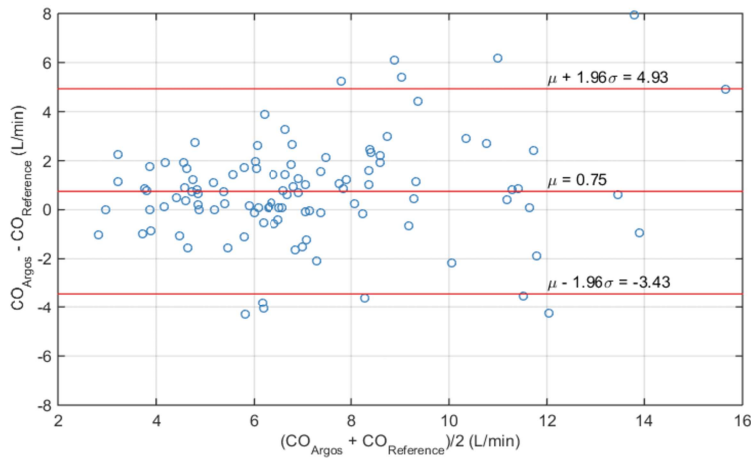

Fig. 9-8: Bland-Altman plot comparing Argos CO to reference CO. LOA [-3.43 to 4.93]

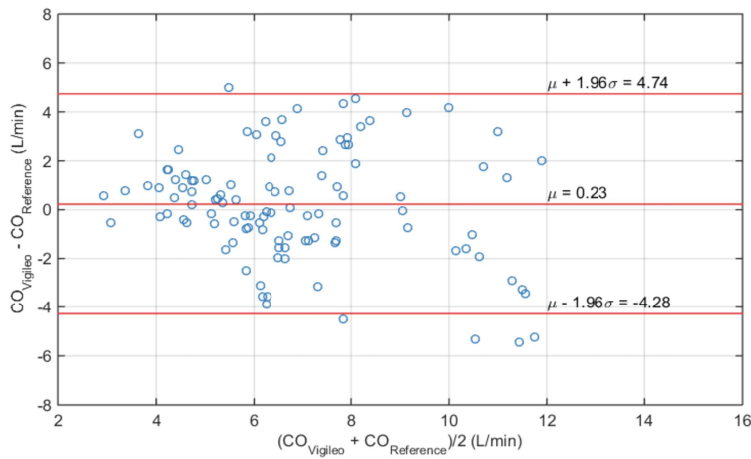

Fig. 9-9: Bland-Altman plot comparing Vigileo CO to reference CO. LOA [-4.28 to 4.74]

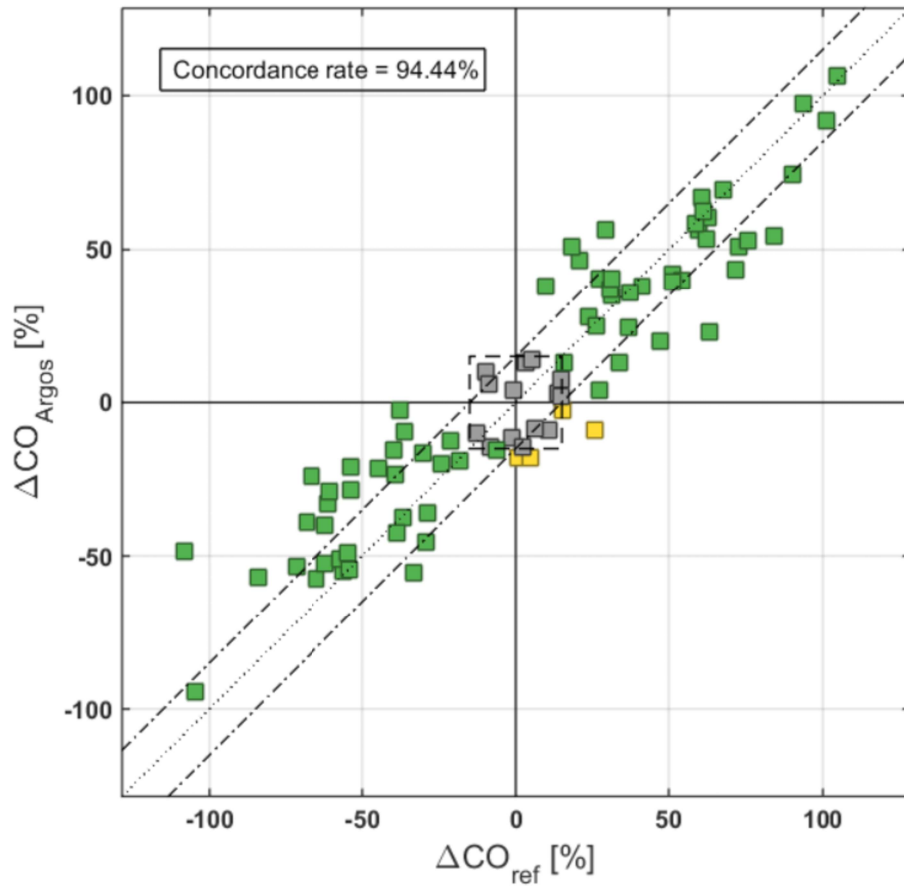

Fig. 9-10: : Concordance plot for percentage changes in Argos CO versus percentage changes in reference CO

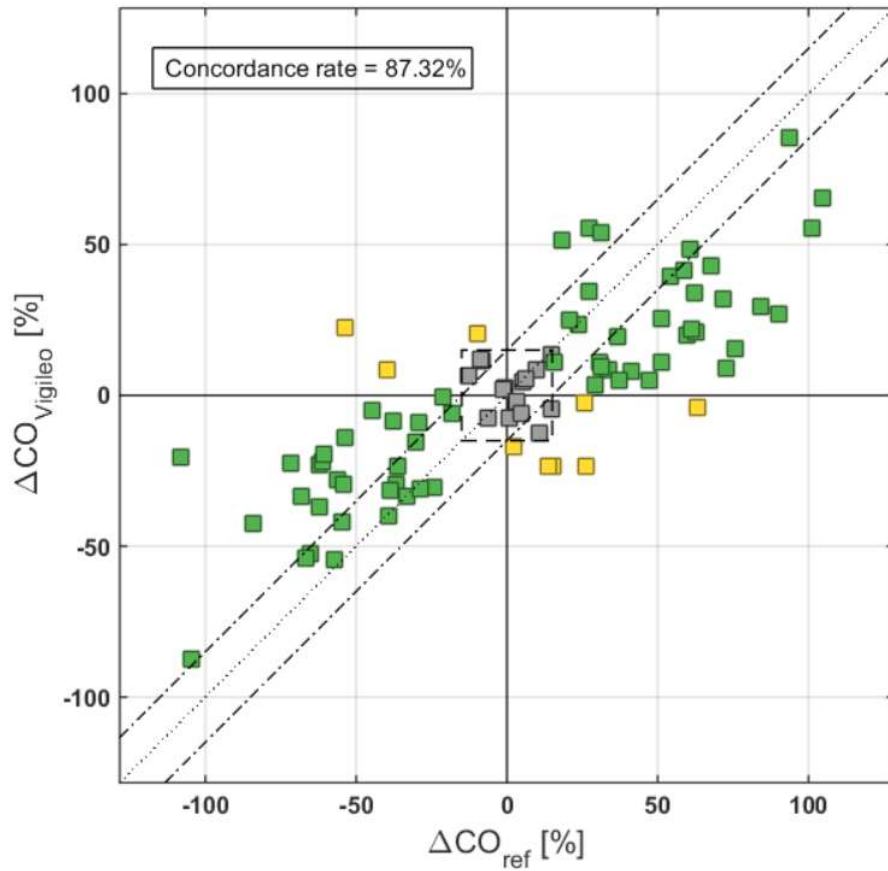

Fig. 9-11: Concordance plot for percentage changes in Vigileo CO versus percentage changes in reference CO

10 Manufacturer's Declaration

10.1 Retia Medical Systems, Inc. Headquarters

333 Westchester Avenue
White Plains, NY 10604
(+1) 914 437 6704
info@retiamedical.com

10.2 Monitor Disposal

Before disposing, to avoid contamination of individuals, the environment, or other equipment, make sure the monitor and/or cables are properly disinfected and decontaminated in accordance with local and national laws regulating the disposal of equipment containing electrical and electronic parts.

For single-use parts and accessories, where not otherwise specified, follow local and institutional regulations regarding disposal of hospital waste.

10.3 Warranty

Retia Medical (Retia) warrants that the Argos Cardiac Output Monitor is fit for the purposes and indications described in the labeling for a period of one (1) year from the date of purchase when used in accordance with the directions for use. Unless the equipment is used in accordance with such instructions, this warranty is void and of no effect. No other express or implied warranty exists, including any warranty of merchantability or fitness for a particular purpose. This warranty does not include cables and connectors used with the Argos Cardiac Output Monitor. Retia Medical's sole obligation and purchaser's exclusive remedy for breach of any warranty shall be limited to repair or replacement of the Argos Cardiac Output Monitor at Retia Medical's option. Retia Medical shall not be liable for proximate, incidental, or consequential damages. Retia Medical shall not be obligated under this warranty to repair or replace a damaged or malfunctioning Argos Cardiac Output Monitor if such damage or malfunction is caused by the customer's use of accessories other than those certified by Retia Medical.

Index

4-way stopcock.....	8, 23, 24, 52, 53
accessories.....	5, 8, 24, 145, 148, 151, 168
Add Patient Data.....	26, 43, 53-56, 89
alarms.....	15, 33, 43, 60, 146
alcohol.....	151
alerts.....	31, 33, 36, 45 , 62, 144, 150, 153
alert limits.....	44, 45, 63, 72, 73, 144, 153
analog output.....	23
aortic valve regurgitation.....	1
Argos monitor.....	1, 4-9, 16-19, 22-26, 30, 33, 43, 52, 53, 56, 60, 61, 143, 148, 150-152
about.....	93
accessories.....	168
alcohol.....	151
bleach.....	151, 152
cleaning.....	151
damage.....	4, 5, 7, 8, 13, 22, 24, 168
decontaminate.....	168
dimensions.....	145
disinfect.....	168
purposes.....	168
replacement.....	151, 168
serial number.....	153
software.....	5, 93, 94
Support.....	150
Table/pedestal stand.....	147
version.....	5, 93, 150
wear.....	152
weight.....	145
arrhythmias.....	5
arterial.....	1, 2, 5-8, 18, 22, 24, 35, 52, 53, 61, 63, 79, 143, 147-149, 154
arterial line.....	7, 8, 22, 24, 61
averaging time.....	150
baseline.....	110
battery.....	22, 51, 86, 87, 143
battery icons.....	87
bedside patient monitor.....	2, 5, 7-9, 11, 22, 23, 25, 30, 33, 43, 52, 53, 60, 61, 145, 147, 148
bibliography.....	154
biohazard.....	8, 24
Bland-Altman plot.....	158
blood pressure.....	2, 5, 29, 30, 43, 63, 148
BP.....	2, 19, 29, 31, 60, 61, 63, 143, 144, 148, 150
blood pressure signal.....	143, 144
bolus.....	154
BP Transducer Kit.....	52, 53
cable.....	6, 8, 10, 17-19, 21, 22, 24, 143, 151-153, 168
cables.....	6, 8, 17, 19, 24, 151, 152, 168
Cardiac Index.....	2, 63, 69, 148, 149
CI.....	2, 63, 69, 70, 148-150
cardiac output.....	1
Cardiac Output.....	2, 5 , 8, 16, 24, 25, 43, 63, 66, 69, 87, 144, 147, 148
CO.....	2, 63, 66, 69, 74, 143, 144, 146, 148, 150
Cardiac Output Monitor.....	5, 16, 25, 43, 87, 144, 147
cardiac support.....	1

catheter.....	6, 7, 18, 22, 52, 53, 143, 154
caution.....	3-5, 9, 13, 18, 19, 22, 23, 25, 43, 87, 97, 98, 124, 139, 151, 152
CAUTION.....	4, 5, 9, 18, 19, 22, 23, 87, 97, 98, 124, 139, 151, 152
chronology.....	100
clinician.....	5, 25
color.....	36, 45, 63, 70-72, 87, 97, 150
concordance plot.....	159, 160
Conducted Immunity.....	2
connectors.....	18, 19, 151, 152, 168
contraindications.....	1
corrosion.....	19, 152
data capacity.....	55
data export.....	11, 19, 56, 88, 91, 92
Data I/O label.....	11
data port.....	11, 90, 91, 152
date.....	51, 88, 97, 150
date and time.....	51, 88, 96, 97, 115
defaults.....	32, 37, 54, 66, 75, 77, 78, 81, 88, 96, 97, 150
restore defaults.....	81, 88, 96, 97
defibrillation.....	15, 23, 146
definition.....	2
demographic.....	26, 27, 30, 54-58, 60, 89, 115
Diastolic pressure.....	143
directions for use.....	168
Display.....	145
disposal.....	8, 24, 168
download.....	5
Draeger.....	147
Dynamic Assessment.....	51, 85, 101
Dynamic Assessment.....	68
Dynamic Assessment History.....	86
electrocautery.....	2
electrocautery equipment.....	19
electrolytic solution.....	19, 152
electromagnetic environment.....	1
electromagnetic immunity.....	1, 2
electromagnetic interference.....	2, 143
Electronic Medical Records (EMR).....	4, 27, 94, 95, 98, 115, 117, 119, 124, 125, 135-137
Capsule.....	119, 135-138
Corepoint.....	59, 119, 123, 135, 137
Electrostatic discharge.....	1
electrosurgical equipment.....	143
emissions.....	1, 8, 19, 24
EMR.....	119
End Patient Session.....	40-42, 56
equations.....	148
errors.....	3, 92, 143, 144, 153
events.....	86, 99, 100
event history.....	100
Flags.....	101
Events access indicator.....	85
excitation voltage.....	7, 19, 22, 152
Expired Baseline.....	113
External monitor.....	11
femoral.....	1, 2, 4, 6, 7, 18, 22, 52, 53, 61, 144, 154, 161
FG-008: Network Connectivity Kit.....	119

FG-009: Serial Connectivity Kit.....	119
fluid bolus.....	102
Fluid Bolus.....	85
Fluid Bolus.....	102
fluid responsive.....	109
GE.....	147
GE Solar Monitors.....	147
glutaraldehyde.....	151
graph.....	79
hazard.....	4, 6, 8, 18, 23, 24, 144, 151
heart rate.....	2, 63, 148
HR.....	2, 63, 148, 150
hemodynamic.....	1, 68, 81, 98, 119, 135, 144, 148, 154
HL7 protocol.....	119
hypertension.....	143
hypotension.....	143
incision.....	162
indications.....	168
indications for use.....	1, 5, 26, 33, 75, 86, 87, 144
ingress.....	6, 15, 17, 146
insulation.....	152
intra-aortic balloon pump.....	1
Invalid Baseline.....	112
keyboard.....	99, 101
label.....	4, 10
labeling.....	168
Lactated Ringers.....	19, 152
LAN.....	119, 130, 147
License.....	58, 86, 94, 95, 98, 115, 119, 124-130
logo.....	10
logs.....	86
LVAD.....	1
maintenance.....	5, 151
malfunction.....	143, 168
Manufacturer's Declaration of Conformity Electronic Emissions and Immunity.....	1
Mean Arterial Pressure.....	2, 35, 63, 79, 148
MAP.....	2, 35, 36, 43, 63, 65, 66, 74, 80, 148-150
menu.....	40, 50, 51, 86, 88-90
menu bar.....	85
Mindray.....	147
motion artifact.....	143
mount.....	2, 6, 16, 17
MRI scanner.....	8
NaCl.....	19, 152
navigation.....	9, 25, 88
network.....	1, 58, 86, 116, 119, 124, 132, 133, 135-137, 143, 152
Network galvanic isolator.....	119
No Signal Detected timeout.....	117
noise.....	143, 144
non-responsive result.....	107
not fluid responsive.....	109
parameter.....	5, 32-36, 43-45, 60, 62-67, 69, 70, 72, 79, 97, 144, 146, 148, 150
index.....	45
parameters.....	1, 2, 5, 34-36, 43, 45, 62, 63, 69, 135, 144-146, 148, 150
parameter limits.....	5, 60, 70, 97
parameter ranges.....	38, 78-81, 97, 146

parameters.....	32
parts and accessories.....	147, 168
Passive Leg raise.....	107
Passive Leg Raise.....	51, 85, 102
patient 1, 4-9, 17, 18, 22, 23, 25-27, 30, 32, 40, 42, 43, 51-56, 58, 60-62, 66, 69, 86, 88, 89, 91, 97, 98, 143, 152, 153	
patient ID.....	27, 28, 56, 57, 91
Patient Record Query.....	135, 137
Patient Setup screen.....	41
pediatric patients.....	1, 5
Philips.....	119, 130-132, 135, 147
Philips EC10.....	130
Philips EC5.....	130
Philips IntelliVue Monitor.....	130
phlebostatic axis.....	7, 22, 52, 143
power.....	6, 7, 17, 19-22, 24, 26, 51, 53, 86-88, 143, 145, 152
Power Frequency Magnetic Immunity.....	2
Power label.....	10
power supply.....	1, 2, 6, 7, 13, 17, 20
Power supply.....	13
Power switch.....	10, 19, 21, 39, 42, 92
pressure tubing.....	8, 24
pulse.....	2, 5, 7, 22, 63, 143, 149
Pulse Pressure Variation.....	2, 3, 5, 149
PPV.....	2, 63, 149, 150
quickstart guide.....	147
radiation.....	7, 18
repair.....	151, 168
replace.....	143, 151, 168
reset.....	81
Resume/Restart Previous Patient.....	55, 60, 89, 93
Retia.....	3, 7, 8, 16, 19, 20, 23, 143, 144, 148, 151-153
contact.....	3, 5, 7, 12, 16, 19, 20, 22, 143, 144, 151-153
customer support.....	3, 52, 147
email contact.....	16, 144, 153, 168
product ID.....	10
RF communication equipment.....	19
RF emissions.....	1
RF interference.....	1
screen 5, 25, 26, 28, 30, 31, 32, 36, 37, 39, 41-43, 44, 51, 53-56, 58, 60-63, 65, 69, 70, 72, 73, 79, 81, 85, 89, 90, 92, 94, 96, 99-101, 145	
Select Blood Pressure Signal Source.....	30, 61
sensor.....	8, 24
Serial Connectivity Kit.....	147
service.....	150, 151, 153
service manual.....	147
settings.....	33, 34, 36, 45, 46, 50, 63, 64, 66, 67, 69, 70, 72, 73, 75, 77-81, 86, 88, 95-98, 150
settings, advanced.....	96, 98, 99, 124-126, 129, 132, 135, 136, 139
setup.....	16, 23, 28, 41, 43, 51-54
shipping label.....	14
Show % change.....	67-69, 150
shut down.....	39-42, 86, 87, 92, 93, 152
signal quality.....	19, 143
software.....	5, 93, 94, 124, 143
software upgrade.....	98, 115, 124, 125, 138-142

Spacelabs Xprezzon.....147

specifications.....**3, 6, 8, 18, 23, 144-146, 148**

 alerts.....150

 Ambient Pressure.....146

 Electrical.....145

 Frequency.....145

 Power Consumption.....145

 Voltage.....145

 Environmental.....145

 Humidity.....146

 Mechanical.....144, 145

 Operating Conditions.....145

 Physical.....144, 145

 temperature.....6, 9, 18, 146

standard.....1, 2, 6, 7

 air pressure.....6, 18

 electrical protection class.....146

 equipment class.....146

 humidity.....6, 12, 18

 IEC.....7, 15, 18, 146

 IP.....15, 17, 146

 IP rating.....12

 ISTA.....15, 146

 temperature.....12

 WEEE.....13

start (bootup).....26, 81

Start New Patient Session.....26, 53, 56, 58

Storage.....145, 146

Stroke Volume.....2, 69, 148

 SV.....2, 63, 69, 72, 148, 150

 SVI.....45

Stroke Volume Index.....2, 45, 69, 148

 SV.....45

 SVI.....2, 63, 69, 148, 150

Systemic Vascular Resistance.....2, 148, 149

 SVR.....2, 63, 148, 150

Systemic Vascular Resistance Index.....2, 149

 SVRI.....2, 63, 149, 150

Systolic Pressure.....143

tabular view.....83

Tabular view.....47, 48, 81, 82

Tabular View.....43, 46-49, 81-85

tampering.....3, 4, 7, 20, 151

thermodilution.....154, 161

time.....46, 51, 66, 88, 97, 99, 150

time movement.....37, 44, 74, 75

time scale.....36-38, 75-79, 97

Trademark.....**3**

transducer.....1, 4, 6-8, 11, 17, 21-24, 30, 31, 52, 53, 60-62, 86, 89, 90, 143

 stopcock.....31, 62, 143

 Zero.....31, 61, 62, 89, 90, 143

Transducer.....11

Transducer Interface Cable.....52, 53

transducer line-in.....11

transducer must be zeroed.....31

Transport.....145, 146

Trend screen.....32, 35, 36, 39, 42, 44, 60, 63, 65, 73, 75, 77, 79, 81, 92, 100, 101

coordinates.....46, 79-81
 scrubbing.....50
 Trend scrubbing.....84
 unit.....2, 6, 8, 18, 19, 24, 26, 54, 77, 88, 97, 148, 150
 units.....2, 6, 18, 54, 77, 150
 unstable baseline.....110
 UPS.....2
 use.....1, 4-9, 13, 16-26, 30, 43-45, 54-56, 60, 61, 66, 80, 86-89, 99, 101, 143, 144, 151, 152, 168
 user guide (manual).....4, 5, 8, 9, 12, 24, 25
 user interface.....145
 Utah Medical.....147
 ventilation.....6, 18
 Verification failed.....143, 153
 vital signs monitor.....11, 143
 Voltage Dips and Interrupts.....2
 Voltage Fluctuations.....1
 warning.....4, 5, 9, 25, 43
 WARNING.....1, 3-9, 13, 16-18, 20-26, 31, 33, 39, 42, 43, 52, 54-56, 60, 61, 87, 89, 92, 144, 147, 148, 151, 153
 WARNING.....3
 warranty.....168
 waste.....8, 24, 168
 water.....151, 152
3
 bar.....30, 51
 bar located on the bottom left hand side of the screen.....40
 Connectivity Kit.....119
 Retia.....**168**